

VOL. 6, NO. 1

# URAL MATHEMATICAL JOURNAL

N.N. Krasovskii Institute of Mathematics and Mechanics of  
the Ural Branch of Russian Academy of Sciences and  
Ural Federal University named after the first President of Russia B.N.Yeltsin

ISSN: 2414-3952

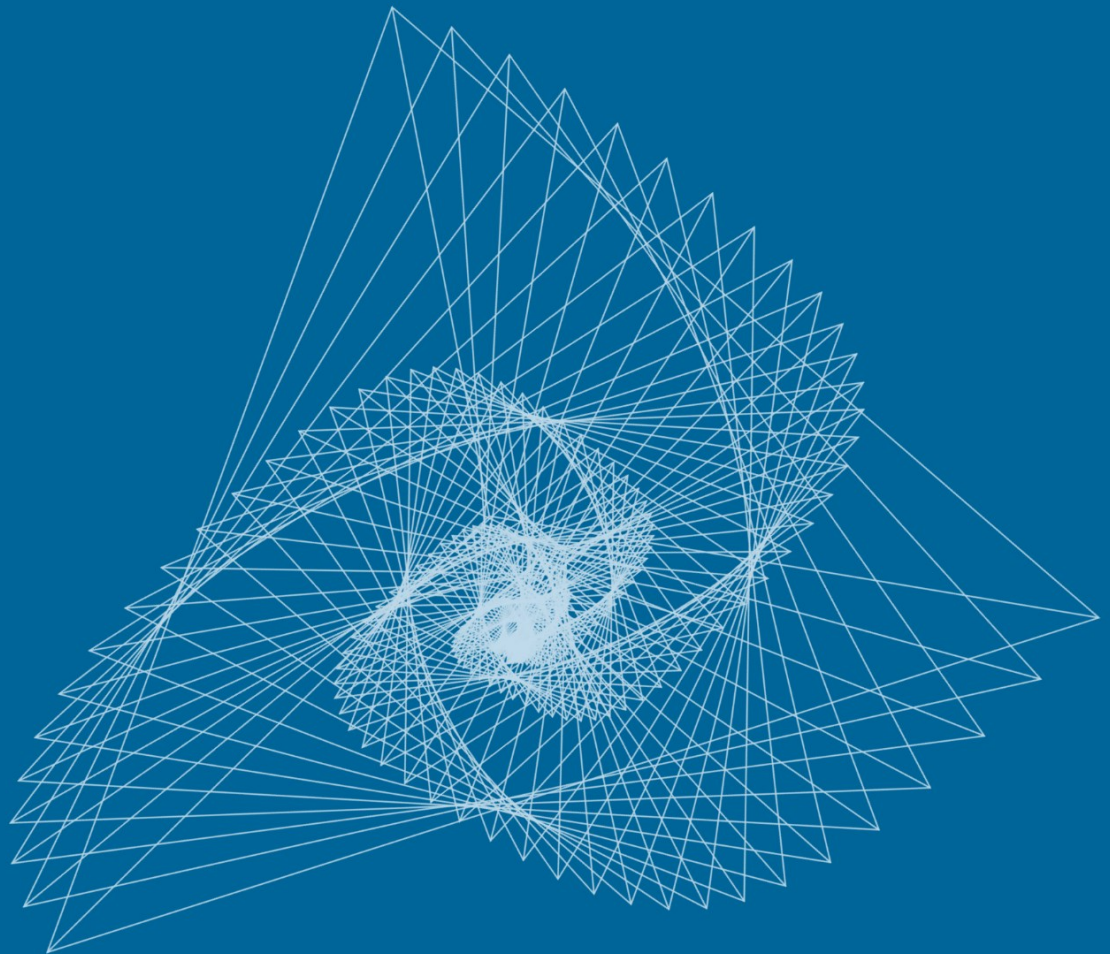



*Electronic Periodical Scientific Journal*  
Founded in 2015

*The Journal is registered by the Federal Service for Supervision in the Sphere of  
Communication, Information Technologies and Mass Communications  
Certificate of Registration of the Mass Media Эп № ФЦ77-61719 of 07.05.2015*

### Founders

N.N. Krasovskii Institute of Mathematics and Mechanics of the Ural  
Branch of Russian Academy of Sciences  
Ural Federal University named after the first President of Russia  
B.N. Yeltsin

### Contact Information

16 S. Kovalevskaya str., Ekaterinburg, Russia, 620990  
Phone: +7 (343) 375-34-73 Fax: +7 (343) 374-25-81  
Email: [secretary@umjuran.ru](mailto:secretary@umjuran.ru)  
Web-site: <https://umjuran.ru>

## EDITORIAL TEAM

### EDITOR-IN-CHIEF

*Vitalii I. Berdyshev*, Academician of RAS, Krasovskii Institute of Mathematics and Mechanics, Ural Branch of the Russian Academy of Sciences, Ekaterinburg, Russia

### DEPUTY CHIEF EDITORS

*Vitalii V. Arestov*, Ural Federal University, Ekaterinburg, Russia

*Nikolai Yu. Antonov*, Krasovskii Institute of Mathematics and Mechanics, Ural Branch of the Russian Academy of Sciences, Ekaterinburg, Russia  
*Vladislav V. Kabanov*, Krasovskii Institute of Mathematics and Mechanics, Ural Branch of the Russian Academy of Sciences, Ekaterinburg, Russia

### SCIENTIFIC EDITORS

*Tatiana F. Filippova*, Krasovskii Institute of Mathematics and Mechanics, Ural Branch of the Russian Academy of Sciences, Ekaterinburg, Russia  
*Vladimir G. Pimenov*, Ural Federal University, Ekaterinburg, Russia

### EDITORIAL COUNCIL

*Alexander G. Chentsov*, Krasovskii Institute of Mathematics and Mechanics, Ural Branch of the Russian Academy of Sciences, Ekaterinburg, Russia  
*Alexander A. Makhnev*, Krasovskii Institute of Mathematics and Mechanics, Ural Branch of the Russian Academy of Sciences, Ekaterinburg, Russia  
*Irina V. Melnikova*, Ural Federal University, Ekaterinburg, Russia  
*Fernando Manuel Ferreira Lobo Pereira*, Faculdade de Engenharia da Universidade do Porto, Porto, Portugal  
*Stefan W. Pickl*, University of the Federal Armed Forces, Munich, Germany  
*Szilárd G. Révész*, Alfréd Rényi Institute of Mathematics of the Hungarian Academy of Sciences, Budapest, Hungary  
*Lev B. Ryashko*, Ural Federal University, Ekaterinburg, Russia  
*Arseny M. Shur*, Ural Federal University, Ekaterinburg, Russia  
*Vladimir N. Ushakov*, Krasovskii Institute of Mathematics and Mechanics, Ural Branch of the Russian Academy of Sciences, Ekaterinburg, Russia  
*Vladimir V. Vasin*, Krasovskii Institute of Mathematics and Mechanics, Ural Branch of the Russian Academy of Sciences, Ekaterinburg, Russia  
*Mikhail V. Volkov*, Ural Federal University, Ekaterinburg, Russia

### EDITORIAL BOARD

*Elena N. Akimova*, Krasovskii Institute of Mathematics and Mechanics, Ural Branch of the Russian Academy of Sciences, Ekaterinburg, Russia  
*Alexander G. Babenko*, Krasovskii Institute of Mathematics and Mechanics, Ural Branch of the Russian Academy of Sciences, Ekaterinburg, Russia  
*Vitalii A. Baranskii*, Ural Federal University, Ekaterinburg, Russia  
*Elena E. Berdysheva*, Department of Mathematics, Justus Liebig University, Giessen, Germany  
*Alexey R. Danilin*, Krasovskii Institute of Mathematics and Mechanics, Ural Branch of the Russian Academy of Sciences, Ekaterinburg, Russia  
*Yuri F. Dolgii*, Ural Federal University, Ekaterinburg, Russia  
*Vakif Dzhafarov (Cafer)*, Department of Mathematics, Anadolu University, Eskişehir, Turkey  
*Polina Yu. Glazyrina*, Ural Federal University, Ekaterinburg, Russia  
*Mikhail I. Gusev*, Krasovskii Institute of Mathematics and Mechanics, Ural Branch of the Russian Academy of Sciences, Ekaterinburg, Russia  
*Éva Gyurkovics*, Department of Differential Equations, Institute of Mathematics, Budapest University of Technology and Economics, Budapest, Hungary  
*Marc Jungers*, National Center for Scientific Research (CNRS), CRAN, Nancy and Université de Lorraine, CRAN, Nancy, France  
*Mikhail Yu. Khachay*, Krasovskii Institute of Mathematics and Mechanics, Ural Branch of the Russian Academy of Sciences, Ekaterinburg, Russia  
*Anatolii F. Kleimenov*, Krasovskii Institute of Mathematics and Mechanics, Ural Branch of the Russian Academy of Sciences, Ekaterinburg, Russia  
*Anatoly S. Kondratiev*, Krasovskii Institute of Mathematics and Mechanics, Ural Branch of the Russian Academy of Sciences, Ekaterinburg, Russia  
*Vyacheslav I. Maksimov*, Krasovskii Institute of Mathematics and Mechanics, Ural Branch of the Russian Academy of Sciences, Ekaterinburg, Russia  
*Dmitrii A. Serkov*, Krasovskii Institute of Mathematics and Mechanics, Ural Branch of the Russian Academy of Sciences, Ekaterinburg, Russia  
*Alexander N. Seseikin*, Ural Federal University, Ekaterinburg, Russia  
*Alexander M. Tarasyev*, Krasovskii Institute of Mathematics and Mechanics, Ural Branch of the Russian Academy of Sciences, Ekaterinburg, Russia

### MANAGING EDITOR

*Oxana G. Matviychuk*, Krasovskii Institute of Mathematics and Mechanics, Ural Branch of the Russian Academy of Sciences, Ekaterinburg, Russia

### TECHNICAL ADVISOR

*Alexey N. Borbunov*, Ural Federal University, Krasovskii Institute of Mathematics and Mechanics, Ural Branch of the Russian Academy of Sciences, Ekaterinburg, Russia

## TABLE OF CONTENTS

<i>Odiljon S. Akhmedov, Abdulla A. Azamov, Gafurjan I. Ibragimov</i> FOUR-DIMENSIONAL BRUSSELATOR MODEL WITH PERIODICAL SOLUTION . . . . .	3–15
<i>Gabdolla Akishev</i> ESTIMATES OF BEST APPROXIMATIONS OF FUNCTIONS WITH LOGARITHMIC SMOOTHNESS IN THE LORENTZ SPACE WITH ANISOTROPIC NORM . . . . .	16–29
<i>Hassan Belaouidel, Anass Ourraoui, Najib Tsouli</i> GENERAL QUASILINEAR PROBLEMS INVOLVING $p(x)$ -LAPLACIAN WITH ROBIN BOUNDARY CONDITION . . . . .	30–41
<i>Faycal Bouchelaghem, Abdelouaheb Ardjouni, Ahcene Djoudi</i> EXISTENCE AND EXPONENTIAL STABILITY OF POSITIVE PERIODIC SOLUTIONS FOR SECOND-ORDER DYNAMIC EQUATIONS . . . . .	42–53
<i>Chikh Bouzar, Fatima Zahra Tchouar</i> ASYMPTOTIC ALMOST AUTOMORPHY OF FUNCTIONS AND DISTRIBUTIONS . . .	54–70
<i>Mikhail I. Gusev</i> THE LIMITS OF APPLICABILITY OF THE LINEARIZATION METHOD IN CALCULATING SMALL-TIME REACHABLE SETS . . . . .	71–83
<i>Abdelhak Hafdallah</i> OPTIMAL CONTROL FOR A CONTROLLED ILL-POSED WAVE EQUATION WITHOUT REQUIRING THE SLATER HYPOTHESIS . . . . .	84–94
<i>Mohamed Abdelhak Kara, Benharrat Belaïdi</i> GROWTH OF $\varphi$ -ORDER SOLUTIONS OF LINEAR DIFFERENTIAL EQUATIONS WITH MEROMORPHIC COEFFICIENTS ON THE COMPLEX PLANE . . . . .	95–113
<i>S. Maadani, G. R. Mohtashami Borzadaran, A. H. Rezaei Roknabadi</i> A NEW GENERALIZED VARENTROPY AND ITS PROPERTIES . . . . .	114–129
<i>Victor S. Polenov, Lyubov A. Kukarskikh, Dmitry A. Nitsak</i> THE DYNAMIC DEFORMATION OF THREE-COMPONENT POROUS MEDIA . . . . .	130–136
<i>Pramod Kumar Rawat</i> ON GENERALIZED EIGHTH ORDER MOCK THETA FUNCTIONS . . . . .	137–146
<i>B. Senthilkumar, Y. B. Venkatakrishnan, H. Naresh Kumar</i> DOMINATION AND EDGE DOMINATION IN TREES . . . . .	147–152
<i>Tursun K. Yuldashev, Bakhtiyor J. Kadirkulov</i> NONLOCAL PROBLEM FOR A MIXED TYPE FOURTH-ORDER DIFFERENTIAL EQUATION WITH HILFER FRACTIONAL OPERATOR . . . . .	153–167
<i>Elias Zikkos</i> MOMENT PROBLEMS IN WEIGHTED $L^2$ SPACES ON THE REAL LINE . . . . .	168–175

# FOUR-DIMENSIONAL BRUSSELATOR MODEL WITH PERIODICAL SOLUTION<sup>1</sup>

**Odiljon S. Akhmedov**

Uzbekistan Academy of Sciences V.I. Romanovskiy Institute of Mathematics,  
Tashkent, 100041 Uzbekistan  
[odiljon.axmedov@gmail.com](mailto:odiljon.axmedov@gmail.com)

**Abdulla A. Azamov**

Uzbekistan Academy of Sciences V.I. Romanovskiy Institute of Mathematics,  
Tashkent, 100041 Uzbekistan  
[abdulla.azamov@gmail.com](mailto:abdulla.azamov@gmail.com)

**Gafurjan I. Ibragimov**

Department of Mathematics & Institute for Mathematical Research,  
University Putra Malaysia, 43400 Serdang Selangor, Malaysia  
[ibragimov@upm.edu.my](mailto:ibragimov@upm.edu.my)

**Abstract:** In the paper, a four-dimensional model of cyclic reactions of the type Prigogine’s Brusselator is considered. It is shown that the corresponding dynamical system does not have a closed trajectory in the positive orthant that will make it inadequate with the main property of chemical reactions of Brusselator type. Therefore, a new modified Brusselator model is proposed in the form of a four-dimensional dynamic system. Also, the existence of a closed trajectory is proved by the DN-tracking method for a certain value of the parameter which expresses the rate of addition one of the reagents to the reaction from an external source.

**Keywords:** Chemical reaction, Closed trajectory, DN-tracking method, Discrete trajectory, Numerical trajectory.

## 1. Introduction

Cyclic (oscillating) reactions such as the Brusselator of Prigogine [12, 24, 25] are of importance in the kinetic theory of chemical reactions.

The mechanism of this reaction is described by the following reactions:

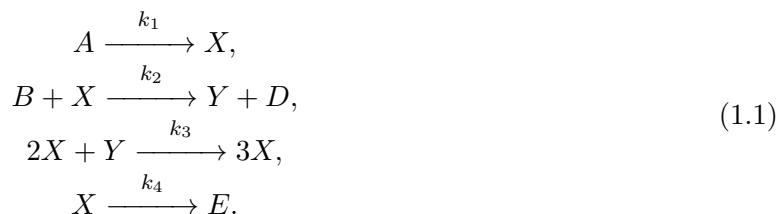

The mathematical model of such reactions is also called Brusselator and serves as an important tool for their study. In fact, the Brusselator is adequately described by a system of two

<sup>1</sup>This work was supported by the grant of the Ministry of Innovative Development of the Republic of Uzbekistan (Project No. OT-Φ4-84).

parabolic equations (diffusion and transfer equations) with respect to the concentrations of substances involved in the reaction that occurs in a given region in  $\mathbb{R}^3$  (see [20, system (7.11)] and also [1, 2, 30, 34]). In practice, one mainly considers models in the form of a system of ordinary differential equations for averaged concentrations of substances  $A, B, X, Y, D$ , and  $E$  involved in the reaction

$$\begin{aligned} \frac{dA}{dt} &= -k_1A, & \frac{dB}{dt} &= -k_2BX, & \frac{dX}{dt} &= k_1A - k_2BX + k_3X^2Y - k_4X, \\ \frac{dY}{dt} &= k_2BX - k_3X^2Y, & \frac{dD}{dt} &= k_2BX, & \frac{dE}{dt} &= k_4X, \end{aligned} \quad (1.2)$$

where the parameters  $k_i = \text{const}$  characterize the reaction rate constants of reaction (1.1).

The reagents  $D$  and  $E$  express the final products of reaction, therefore, their influence on other quantities can be neglected, and so we focus only on the dynamics of the reagents  $A, B, X$ , and  $Y$ . Assuming that the concentrations of  $A$  and  $B$  remain unchanged, after substituting  $X = \lambda x$ ,  $Y = \lambda y$ , and  $t = \mu\tau$ , model (1.2) reduces to the second-order dynamical system

$$\begin{aligned} \frac{dx}{d\tau} &= a - bx + x^2y - x, \\ \frac{dy}{d\tau} &= bx - x^2y, \end{aligned} \quad (1.3)$$

where  $\lambda = \sqrt{\frac{k_4}{k_3}}$ ,  $\mu = \frac{1}{k_4}$ ,  $a = \frac{k_1A}{\lambda}\mu$ , and  $b = k_2B\mu$ . For system (1.3) and its diffusion form, the constructions of both phase portraits and bifurcations were completely studied [17–19, 22, 26, 28, 29, 31–33].

The three-dimensional model with the positive dynamics of the reagent  $B$  was also studied in the case when the corresponding reagent is constantly added to the reaction with the rate  $\beta$  [14]. In this case, the substitution  $X = \lambda x$ ,  $Y = \lambda y$ ,  $B = \lambda b$ , and  $t = \mu\tau$  into system (1.2) gives

$$\begin{aligned} \frac{db}{d\tau} &= -bx + \tilde{\beta}, \\ \frac{dx}{d\tau} &= \tilde{a} - bx + x^2y - \tilde{c}x, \\ \frac{dy}{d\tau} &= bx - x^2y, \end{aligned} \quad (1.4)$$

where

$$\lambda = \frac{k_2}{k_3}, \quad \mu = \frac{k_3}{k_2^2}, \quad \tilde{a} = \frac{k_1A}{\lambda}\mu, \quad \tilde{c} = k_4\mu, \quad \tilde{\beta} = \frac{\beta}{\lambda}\mu.$$

System (1.4) still has a periodic trajectory, for example, for  $\tilde{a} = 1$ ,  $\tilde{c} = 1$ , and for a certain range of the parameter  $\beta$ . In [11], a full Brusselator model taking into account the diffusion was studied and its mathematical description of a long-term behavior was developed.

In [4, 6], with the use of the discrete-numerical tracking (DN-tracking) method [3], the existence of a closed trajectory was proved for specific values of the parameters of two-dimensional and three-dimensional systems of the Brusselator model, respectively.

Notice that, if the initial concentration of the reagent  $A$  is equal to  $\lambda/(k_1\mu)$  and it is added to the reaction with the rate  $\lambda/\mu$ , then one can provide the equality  $\tilde{a} = 1$ , and if the reaction rate  $k_4$  of  $X \xrightarrow{k_4} E$  is equal to  $1/\mu$ , then  $\tilde{c} = 1$ .

In the present paper, we consider the problem of the existence of a periodic regime in the four-dimensional model of Brusselator, where the dynamics of all reagents  $A, B, X$ , and  $Y$  are of

interest. In the classic case, the Brusselator system has the form

$$\begin{aligned}\frac{dA}{dt} &= -k_1A, \\ \frac{dB}{dt} &= -k_2BX + \beta, \\ \frac{dX}{dt} &= k_1A - k_2BX + k_3X^2Y - k_4X, \\ \frac{dY}{dt} &= k_2BX - k_3X^2Y.\end{aligned}\tag{1.5}$$

Due to the first equation of (1.5), which corresponds to the reaction  $A \xrightarrow{k_1} X$ , system (1.5) cannot have a closed trajectory in the positive orthant  $A > 0, B > 0, X > 0, Y > 0$  for any values of parameters  $k_i, i = 1, 4$  and  $\beta$ , since  $A(t) \rightarrow 0$  as  $t \rightarrow +\infty$ . Based on this circumstance, one may conclude that the model (1.5) does not possess the main property of the Brusselator, that is, there is no an attractor, namely, an asymptotically stable periodic trajectory.

The simplest way to correct this is to replace the equation

$$\frac{dA}{dt} = -k_1A$$

by the equation

$$\frac{dA}{dt} = -k_1A + \alpha,$$

where  $\alpha > 0$ , i.e., to add some compensation of the reagent  $A$  from an external source with the rate  $\alpha$ . However, in this case, it is easy to see that  $A(t) \rightarrow \alpha/k_1$  as  $t \rightarrow +\infty$  for any initial concentration of  $A$  unless it is equal to 0, meaning that there is no a closed trajectory. Moreover, the restriction of the new system to the invariant hyperplane  $A = \alpha/k_1$  coincides with system (1.4).

The other way to compensate the concentration of  $A$  is to replace the reagent  $D$  with  $A$  in the bimolecular reaction  $B + X \xrightarrow{k_2} Y + D$ , i.e., to consider the new mechanism of reaction as

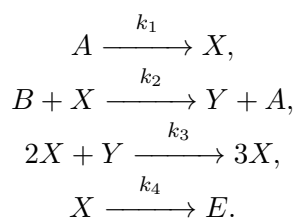

Then, a modified 4-dimensional Brussellator model corresponding to the above reaction is

$$\begin{aligned}\frac{dA}{dt} &= -k_1A + k_2BX, \\ \frac{dB}{dt} &= -k_2BX + \beta, \\ \frac{dX}{dt} &= k_1A - k_2BX + k_3X^2Y - k_4X, \\ \frac{dY}{dt} &= k_2BX - k_3X^2Y.\end{aligned}\tag{1.6}$$

In the study of the qualitative behaviour of trajectories of system (1.6), it was established that system (1.6) has a closed trajectory, which will be proved in the next section.

One can use other approaches to obtain a modified Brusselator model with the cyclical regime provided such a model exists. However, our purpose is to get a modified Brusselator model such that its two- and three-dimensional models are the same with the models (1.3) and (1.4), respectively.

Thus, unlike the model (1.5), the dynamics of the component  $A$  in (1.6) is determined by the influence of the reagents  $X$  and  $B$ .

Substituting  $X = \lambda x$ ,  $Y = \lambda y$ ,  $B = \lambda b$ ,  $A = \lambda a$ , and  $t = \mu\tau$ , we can write model (1.6) as follows:

$$\begin{aligned}\frac{da}{d\tau} &= -\alpha a + bx, \\ \frac{db}{d\tau} &= -bx + \tilde{\beta}, \\ \frac{dx}{d\tau} &= \alpha a - bx + x^2y - \gamma x, \\ \frac{dy}{d\tau} &= bx - x^2y,\end{aligned}\tag{1.7}$$

where

$$\lambda = \frac{k_2}{k_3}, \quad \mu = \frac{k_3}{k_2^2}, \quad \alpha = k_1\mu, \quad \gamma = k_4\mu, \quad \tilde{\beta} = \frac{\beta}{\lambda}\mu.$$

## 2. Main result

The rest of the paper is devoted to the proof of below given Theorem 1, which states that model (1.7) has a periodic trajectory for certain values of  $\tilde{\beta}$  and  $\alpha = \gamma = 1$  (meaning that  $k_1 = k_4 = 1/\mu$ ).

In vector form, system (1.7) is

$$\dot{z} = f(z),\tag{2.1}$$

where

$$\begin{aligned}z &= (z_1, z_2, z_3, z_4), \quad f = (f_1, f_2, f_3, f_4), \quad f_1(z) = -z_1 + z_2z_3, \\ f_2(z) &= -z_2z_3 + \tilde{\beta}, \quad f_3(z) = z_1 - z_2z_3 - z_3 + z_3^2z_4, \quad f_4(z) = z_2z_3 - z_3^2z_4.\end{aligned}$$

A computer experiment allows us to formulate the following conjecture: for  $\beta = 1.17$ , system (2.1) has a closed trajectory  $z(t)$  of the period  $T \approx 8.36$  passing near the point  $z_0^{(1)} = (1.11692, 0.99112, 1.09485, 0.80461)$ .

System (2.1) does not have an internal symmetry; moreover, it is impossible to find its integral in explicit form. One may conclude that the only way to prove the existence of a closed trajectory is to apply the method of Poincaré map. To construct the Poincaré map, we use the DN-tracking method [3, 5]. To this end, first, it is necessary to choose the starting point as close to the proposed closed trajectory as possible. The point  $z_0^{(1)}$  defined above is selected as the starting point.

**Theorem 1.** *For  $\tilde{\beta} = 1.17$ , system (2.1) has a closed trajectory in the region*

$$\Pi_4 = \{(z_1, z_2, z_3, z_4) \mid 1.07 \leq z_1 \leq 1.26, 0.85 \leq z_2 \leq 1.15, 0.98 \leq z_3 \leq 1.38, 0.65 \leq z_4 \leq 1.1\}.$$

## 3. Proof of Theorem 1

### 3.1. Preliminaries

Let

$$m_0 = \max_{z \in \Pi_4} \|f(z)\|, \quad m_1 = \max_{z \in \Pi_4} \|f'(z)\|, \quad m_2 = \max_{z \in \Pi_4} \|f''(z)\|, \quad m_3 = \max_{z \in \Pi_4} \|f'''(z)\|,$$

where  $\|\cdot\|$  is the Euclidean norm of tensor quantities of type  $(1, 0)$ ,  $(1, 1)$ ,  $(1, 2)$ , and  $(1, 3)$ , respectively [10].

It is easy to establish the following exact estimates:

$$0.83 < m_0 < 0.85, \quad 4.8 < m_1 < 4.9, \quad 6.9 < m_2 < 7, \quad m_3 = 2\sqrt{6}. \quad (3.1)$$

Let  $P = \{z \in \mathbb{R}^d \mid -0.001 \leq z_i \leq 0.001, i = \overline{1, 4}\}$ . Using the Minkowski–Pontryagin difference [21], we construct the parallelepipeds  $\Pi_j = \Pi_4 - (4 - j)P$ ,  $j = 0, 1, 2, 3$ .

Obviously,  $\Pi_0 \subset \Pi_1 \subset \Pi_2 \subset \Pi_3 \subset \Pi_4$  and  $\text{dist}(\Pi_j, \partial\Pi_{j+1}) = 0.001$ ,  $j = 0, 1, 2, 3$ .

Let  $\Sigma^{(1)}$  be a hyperplane passing through the point  $z_0^{(1)}$  and orthogonal to the vector  $f(z_0^{(1)})$ . On the hyperplane  $\Sigma^{(1)}$ , we introduce the Cartesian coordinate system  $(u, v, w)$  with the origin  $z_0^{(1)}$ . As a basis on  $\Sigma^{(1)}$ , we take the vectors  $u, v, w \in \mathbb{R}^4$  with the coordinates

$$\begin{aligned} u_1 &= n_2, & u_2 &= -n_1, & u_3 &= n_4, & u_4 &= -n_3, \\ v_1 &= \sqrt{n_3^2 + n_4^2}, & v_2 &= 0, & v_3 &= -\frac{n_1n_3 + n_2n_4}{v_1}, & v_4 &= \frac{n_2n_3 - n_1n_4}{v_1}, \\ w_1 &= 0, & w_2 &= v_1, & w_3 &= -v_4, & w_4 &= v_3, \end{aligned} \quad (3.2)$$

where  $n_i = f_i(z_0^{(1)})/|f(z_0^{(1)})|$ ,  $i = \overline{1, 4}$ . It is easy to verify that the vectors  $u, v, w$  defined by (3.2) really form an orthonormal basis on  $\Sigma^{(1)}$ .

As the domain of the Poincaré map, we take the parallelepiped

$$S^{(1)} = \left\{ \xi = (\xi_1, \xi_2, \xi_3) \mid \xi \in \Sigma^{(1)}, -325\delta \leq \xi_1 \leq 325\delta, -20\delta \leq \xi_2 \leq 20\delta, -24\delta \leq \xi_3 \leq 24\delta \right\} \subset \Sigma^{(1)}.$$

Next, we construct a grid

$$K_\delta^{(1)} = \delta M_\delta^{(1)} \subset S^{(1)},$$

where  $\delta = 4 \cdot 10^{-6}$ ,  $M_\delta^{(1)} = \{(i, j, k) \in \mathbb{Z}^3 \mid -325 \leq i \leq 325, -20 \leq j \leq 20, -24 \leq k \leq 24\}$ . Note that the grid  $K_\delta^{(1)}$  contains exactly 1307859 nodes.

It is known that, if analytical and topological methods are not enough for studying the non-local qualitative properties of dynamical systems, then one has to involve the methods of numerical integration and computer visualization. The corresponding approach was given the special name ‘‘Computational Dynamics’’ [13].

For numerical integration of system (2.1), we apply the Runge–Kutta method [7, 9, 15]. For our purpose, a second-order accuracy scheme is sufficient:

$$\tilde{z}^{(n+1)} = \tilde{z}^{(n)} + F(k_1(\tilde{z}^{(n)}, h), k_2(\tilde{z}^{(n)}, h)), \quad n = 0, 1, \dots, \quad (3.3)$$

where  $F(k_1, k_2) = 0.5(k_1 + k_2)$ ,  $k_1 = hf(z)$ ,  $k_2 = hf(z + k_1)$ , and  $\tilde{z}^{(0)} \in K_\delta^{(1)}$ .

We call the approximate solution  $\tilde{z}^{(n)}$  obtained by formula (3.3) the *discrete trajectory* of system (2.1). Note that one cannot find the discrete trajectory explicitly as well as the trajectory of the Cauchy problem, despite the fact that system (2.1) is polynomial. Therefore, one has to work with another sequence of vectors  $\tilde{\zeta}^{(n)}$  to be obtained by rounding the values of  $\tilde{z}^{(n)}$  by a computer [8, 16].

Indeed, in real calculations, due to rounding of the results of arithmetic operations by a computer (in our case, we used a computer with IntelCore i5 processor, frequency of 2.50 GHz and with extended accuracy), instead of the sequence  $\tilde{z}^{(n)}$ , we get another sequence of vectors  $\tilde{\zeta}^{(n)}$ . We call this solution a *numerical trajectory* of system (2.1).

Let  $z_{uvw}(t)$  be the trajectory starting from the point  $z_{uvw}(0) \in S^{(1)}$ , and let  $\tilde{z}_{ijk}(t)$  be the trajectory corresponding to the trajectory  $z_{uvw}(t)$  and starting from the point  $\tilde{z}_{ijk}(0) \in K_\delta^{(1)}$  close



to  $z_{uvw}(0)$ , i.e.,  $i = [u/h + 1/2]$ ,  $j = [v/h + 1/2]$ , and  $k = [w/h + 1/2]$ . It is easy to see that  $|z_{uvw}(0) - \tilde{z}_{ijk}(0)| \leq \sqrt{3}/2\delta$ .

In [27], an algorithm based on a partitioning process and using the interval arithmetics with directed rounding is proposed for computing rigorous solutions to a large class of ordinary differential equations. As an application, it was proved that the Lorenz system supports a strange attractor.

In the present paper, the DN-tracking method is used as the method of proof of the existence of a closed trajectory. It is based on the estimations of the accuracy of numerical and discrete solutions approximating the solution of system (2.1). This requires rigorous proof of the inequalities establishing the accuracy of the estimate. Therefore, it is necessary to derive the required estimate with deductive rigour. The estimations given below were derived in [6] for the considering scheme (3.3) based on two preliminary assumptions.

**Assumption 1.** *The trajectory  $z_{uvw}(t)$  exists on a time interval  $0 \leq t \leq T$  and  $z_{uvw}(t) \in \Pi_4$ .*

**Assumption 2.** *The inclusion  $\tilde{z}^{(n)} \in \Pi_1$  holds for all  $n = 0, 1, \dots, N$ .*

**Estimation 1.**

$$|\tilde{\zeta}^{(n+1)} - \tilde{\zeta}^{(n)}| < m_0 h + \Delta_*, \quad n = \overline{0, N},$$

where  $\Delta_*$  is the local round-off error that produced by scheme (3.3). In our case, the inequality  $\Delta_* < 10^{-14}$  holds.

**Estimation 2.**

$$|\tilde{z}^{(n)} - \tilde{\zeta}^{(n)}| < \frac{e^{LT} - 1}{Lh} \Delta_*, \quad n = \overline{0, N}, \quad (3.4)$$

where  $L = m_1 + 0.5m_1^2 h$ .

**Estimation 3.**

$$|\tilde{z}_{ijk}(nh) - \tilde{z}^{(n)}| < \frac{m_0^2 m_2 + 4m_0 m_1^2}{12m_1} (e^{m_1 T} - 1) h^2, \quad n = \overline{0, N}, \quad (3.5)$$

where  $\tilde{z}_{ijk}(0) = \tilde{z}^{(0)}$ .

**Estimation 4.**

$$|\tilde{z}_{ijk}(t) - \tilde{z}_{ijk}(nh)| < \frac{m_0 h}{2},$$

where  $n = [t/h + 1/2]$ .

**Estimation 5.**

$$|z_{uvw}(t) - \tilde{z}_{ijk}(t)| < \frac{\sqrt{3}}{2} e^{m_1 T} \delta. \quad (3.6)$$

By estimate (3.1),  $m_1 > 4.8$ ; hence,  $e^{m_1 T} > 3 \cdot 10^{17}$ . This inequality means that estimates (3.4), (3.5), and (3.6) are not effective for tracking the trajectories of  $z_{uvw}(t)$  on the time interval  $[0, 8.37]$ . Therefore, to overcome this difficulty, we use the technique of dividing the interval into 23 subintervals:

$$J^{(m)} = [0.37(m-1), 0.37m + 0.03], \quad m = 1, 2, \dots, 22$$

(of length 0.40) and the last one is

$$J^{(23)} = [8.14, 8.37]$$

(of length 0.23).

In this case, on each time interval  $J^{(m)}$ , estimates (3.4)–(3.6) are acceptable to apply the DN-tracking.

### 3.2. Constructing a map on the first segment

Further, we continue the reasoning on the first segment  $J^{(1)} = [0, 0.4]$ . Let  $\tilde{z}_*(t)$  be one of the trajectories  $\tilde{z}_{ijk}(t)$ , let  $\tilde{z}_*^{(n)}$  be the discrete trajectory corresponding to  $\tilde{z}_*(t)$ , i.e., a solution of system (2.1) with the initial condition  $\tilde{z}_*^{(0)} = \tilde{z}_*(0) \in K_\delta^{(1)}$ , and let  $\zeta_*^{(n)}$  be the numerical trajectory corresponding to  $\tilde{z}_*^{(n)}$ . We put  $h = 2^{-16}$ ,  $T = 0.40$ , and  $N = [T/h] = 26214$ .

Using Estimations 1–5 and the method of proof by contradiction, the following Lemmas can be proved in the same way as in [6]. Therefore, here we restrict ourselves to proving Lemma 3.

**Lemma 1.** *For all  $n = 0, 1, \dots, N$ ,*

$$\zeta_*^{(n)} \in \Pi_0 \quad \text{and} \quad \left| \tilde{\zeta}_*^{(n+1)} - \tilde{\zeta}_*^{(n)} \right| < 1.4 \cdot 10^{-5}. \quad (3.7)$$

Since  $\zeta_*^{(n)}$  is a numerical solution kept in the memory of a computer, the validity of the first inclusion in (3.7) is verified by the computer, while the inequality in (3.7) is derived by means of Estimation 1.

**Lemma 2.** *The estimate*

$$\left| \tilde{z}_*^{(n)} - \tilde{\zeta}_*^{(n)} \right| < 8.2 \cdot 10^{-10} \quad (3.8)$$

*holds as long as  $\tilde{z}_*^{(k)} \in \Pi_1$ ,  $k = 0, 1, 2, \dots, n$ .*

Estimate (3.8) can be easily obtained by using estimates (3.1) and substituting the values  $T = 0.40$  and  $h = 2^{-16}$  into the right hand side of (3.4) in Estimation 3.

**Lemma 3.** *Assumption 2 holds.*

*P r o o f.* By Lemma 2, we obtain

$$\left| \tilde{z}_*^{(n)} - \tilde{\zeta}_*^{(n)} \right| < 8.2 \cdot 10^{-10},$$

when the inclusion  $\tilde{z}_*^{(n)} \in \Pi_1$  holds. We now show that this inclusion holds for all  $n = 0, 1, \dots, N$ . We assume the contrary, let for some minimal  $n_* \geq 1$ , we have  $\tilde{z}_*^{(n_*-1)} \in \Pi_1$ , but  $\tilde{z}_*^{(n_*)} \notin \Pi_1$ . Then

$$\left| \tilde{z}_*^{(n_*)} - \tilde{\zeta}_*^{(n_*)} \right| < \left| \tilde{z}_*^{(n_*)} - \tilde{z}_*^{(n_*-1)} \right| + \left| \tilde{z}_*^{(n_*-1)} - \tilde{\zeta}_*^{(n_*-1)} \right| + \left| \tilde{\zeta}_*^{(n_*-1)} - \tilde{\zeta}_*^{(n_*)} \right|.$$

Since by the scheme (3.3) one has the estimation

$$\left| \tilde{z}_*^{(n_*)} - \tilde{z}_*^{(n_*-1)} \right| \leq \max_{z \in \Pi_1} |F(k_1(z), k_2(z))| < m_0 h < 1.3 \cdot 10^{-5},$$

and by assumption, we have  $\tilde{z}_*^{(n_*-1)} \in \Pi_1$  so one can apply Lemma 2 and get the estimation  $\left| \tilde{z}_*^{(n_*-1)} - \tilde{\zeta}_*^{(n_*-1)} \right| < 8.2 \cdot 10^{-10}$ . As for the estimation  $\left| \tilde{\zeta}_*^{(n_*-1)} - \tilde{\zeta}_*^{(n_*)} \right| < 1.4 \cdot 10^{-5}$ , it follows from Lemma 1.

Therefore,

$$\left| \tilde{z}_*^{(n_*)} - \tilde{\zeta}_*^{(n_*)} \right| < 2.8 \cdot 10^{-5}. \quad (3.9)$$

Since  $\tilde{\zeta}_*^{(n_*)} \in \Pi_0$  and  $\text{dist}(\Pi_0, \partial\Pi_1) = 0.001$ , therefore, (3.9) implies that  $\tilde{z}_*^{(n_*)} \in \Pi_1$ . This contradicts the above assumption  $\tilde{z}_*^{(n_*)} \notin \Pi_1$ . Thus, the inclusion  $\tilde{z}_*^{(n)} \in \Pi_1$  holds for all  $n = 0, 1, \dots, N$ , i.e., Assumption 2 holds.  $\square$

**Lemma 4.** For all  $n = 0, 1, \dots, N$ ,

$$\tilde{z}_*(nh) \in \Pi_2 \text{ and } \left| \tilde{z}_*(nh) - \tilde{z}_*^{(n)} \right| < 2.1 \cdot 10^{-9}.$$

**Lemma 5.** Let  $t \in J^{(1)}$  and  $n = [t/h + 1/2]$ . Then

$$\tilde{z}_*(t) \in \Pi_3 \text{ and } |\tilde{z}_*(t) - \tilde{z}_*(nh)| < 6.49 \cdot 10^{-6}.$$

**Lemma 6.** Let  $t \in J^{(1)}$  and  $(u, v, w) \in S^{(1)}$ . Then

$$z_{uvw}(t) \in \Pi_4 \text{ and } |z_{uvw}(t) - z_{ijk}(t)| < 2.46 \cdot 10^{-5}.$$

Lemmas 1–6 imply that Assumption 1 holds on the first segment  $J^{(1)}$  and the following theorem is true.

**Theorem 2.** Let  $t \in J^{(1)}$ . Then

$$z_{uvw}(t) \in \Pi_4 \text{ and } \left| z_{uvw}(t) - \tilde{\zeta}_{ijk}^{(n)} \right| < 3.11 \cdot 10^{-5} = \varepsilon. \quad (3.10)$$

The estimation (3.10) means that one can track any real trajectory  $z_{uvw}(t)$  of system (2.1) by means of the numerical trajectory  $\tilde{\zeta}_{ijk}^{(n)}$  with accuracy  $\varepsilon$ .

Let  $z_0^{(2)} = \tilde{\zeta}_{000}^{(N-1966)}$ , and let  $\Sigma^{(2)}$  be a hyperplane with normal  $f(z_0^{(2)})$  and passing through the point  $z_0^{(2)}$ .

**Theorem 3.** Each trajectory (2.1) intersects the hyperplane  $\Sigma^{(2)}$  at some time  $t_{uvw} \in (T - 0.06, T) = (0.34, 0.4)$ .

The proof of this theorem is directly verified by a computer by showing that the points  $\tilde{\zeta}_{ijk}^{(N-3932)}$  and  $\tilde{\zeta}_{ijk}^{(N)}$  lie in the half-spaces

$$\Omega_+ = \left\{ z \mid \langle z - z_0^{(2)}, f(z_0^{(2)}) \rangle > 0 \right\}, \quad \Omega_- = \left\{ z \mid \langle z - z_0^{(2)}, f(z_0^{(2)}) \rangle < 0 \right\},$$

respectively. Moreover, the distances between these points and  $\Sigma^{(2)}$  are not less than  $\varepsilon$  (Fig. 1).

Therefore, every trajectory  $z_{uvw}(t)$  crosses the plane  $\Sigma^{(2)}$  at some  $t_{uvw} \in (0.34, 0.4)$  and by the implicit function theorem it follows that the function  $t_{uvw}$  is continuous in  $(u, v, w) \in S^{(1)}$ .

Thus, we obtain a map  $\Phi_{(1)}^{(2)}$  of the parallelepiped  $S^{(1)}$  onto the plane  $\Sigma^{(2)}$ , which relates each point  $(u, v, w) \in S^{(1)}$  to a point  $z_{uvw}(t_{uvw})$  where  $z_{uvw}(t)$  intersects the plane  $\Sigma^{(2)}$ . We denote the set of these points by  $S^{(2)}$ . The continuity of the map  $\Phi_{(1)}^{(2)}$  follows from the theorem on the continuous dependence of solutions on the initial point.

### 3.3. Constructing Poincaré map

For the time segments  $J^{(m)}$ ,  $m = \overline{2, 22}$ , we choose the values of  $h$ ,  $T$ , and  $\delta$  the same as for the first segment. Therefore, the estimation (3.10) does not change, that is,  $\varepsilon$  remains unchanged.

On the hyperplane  $\Sigma^{(2)}$ , we introduce again the Cartesian coordinate system  $(u, v, w)$  with the origin  $z_0^{(2)}$  taking the basis on it the vectors defined by (3.2).

Let  $S_\varepsilon^{(2)} = \bigcup_{p \in S^{(2)}} B_\varepsilon(p)$  be the  $\varepsilon$ -neighborhood of the set  $S^{(2)}$ , where  $B_\varepsilon(p)$  is a ball with centre  $p$  and radius  $\varepsilon$ . We denote again the trajectory starting from the point  $(u, v, w) \in S_\varepsilon^{(2)}$  and

the corresponding numerical trajectory by  $z_{uvw}(t)$  and  $\tilde{\zeta}_{ijk}^{(n)}$ , respectively, where  $i = [u/h + 1/2]$ ,  $j = [v/h + 1/2]$ , and  $k = [w/h + 1/2]$ .

For the segment  $J^{(2)}$ , the existence of a map  $\Phi_{(2)}^{(3)}$  of the domain  $S_\varepsilon^{(2)} \subset \Sigma^{(2)}$  to the plane  $\Sigma^{(3)}$  passing through the point  $z_0^{(3)} = \tilde{\zeta}_{00}^{(N-1966)}$  and orthogonal to the vector  $f(z_0^{(3)})$  is established similar to the construction for the first segment.

Repeating a similar reasoning and calculations, we obtain 21 continuous mappings

$$\Phi_{(m)}^{(m+1)} : S_\varepsilon^{(m)} \rightarrow \Sigma^{(m+1)}, \quad m = 2, 3, \dots, 22.$$

The last segment  $J^{(23)} = [8.14, 8.37]$  requires a special consideration. Consider an ensemble of trajectories  $z_{uvw}(t)$  with starting points in  $S_\varepsilon^{(23)}$ . Putting  $h = 2^{-16}$ ,  $T = 0.23$ , and  $N = [T/h] = 15073$ , we find numerical trajectories  $\tilde{\zeta}_{ijk}^{(n)}$  approximating the ensemble of trajectories  $z_{uvw}(t)$ .

Then, for the time interval  $J^{(23)}$ , we prove the following statement.

**Theorem 4.** *Let  $t \in J^{(23)}$ . Then*

$$z_{uvw}(t) \in \Pi_4 \quad \text{and} \quad |z_{uvw}(t) - \tilde{\zeta}_{ijk}^{(n)}| < 1.72 \cdot 10^{-5} = \varepsilon. \quad (3.11)$$

**Theorem 5.** *Let  $\Pi^+$  and  $\Pi^-$  be open half-spaces defined by the hyperplane  $\Sigma^{(1)}$ ; more precisely,*

$$\Pi^+ = \left\{ z \in R^4 \mid \langle z - z_0^{(1)}, f(z_0^{(1)}) \rangle > 0 \right\} \quad \text{and} \quad \Pi^- = \left\{ z \in R^4 \mid \langle z - z_0^{(1)}, f(z_0^{(1)}) \rangle < 0 \right\}.$$

Then  $\tilde{\zeta}_{ijk}^{(N-3932)} \in \Pi^-$  and  $\tilde{\zeta}_{ijk}^{(N)} \in \Pi^+$  for all  $i, j, k$ .

**Corollary 1.** *Every trajectory*

$$z_{uvw}(t) \quad \text{with} \quad (u, v, w) \in S_\varepsilon^{(23)}$$

*reaches the hyperplane  $\Sigma^{(1)}$  at some time  $t_{uvw} \in (8.34, 8.37)$ .*

Mapping a point  $(u, v, w) \in S_\varepsilon^{(23)}$  to the point  $z_{uvw}(t_{uvw})$ , we get a continuous mapping  $\Phi_{(23)}^{(1)} : S_\varepsilon^{(23)} \rightarrow \Sigma^{(1)}$ . Next, we set

$$\Phi = \Phi_{(23)}^{(1)} \circ \Phi_{(22)}^{(23)} \circ \dots \circ \Phi_{(1)}^{(2)}.$$

As a result, we obtain the required Poincaré map (Fig. 2).

Let  $S^\omega = \Phi(S^{(1)})$  and, for fixed  $i, j, k$ , let  $n_{ijk}$  be the number of the term of the sequence  $\tilde{\zeta}_{ijk}^{(n)}$  closest to the hyperplane  $\Sigma^{(1)}$ . We denote the set of all points  $\tilde{\zeta}_{ijk}^{(n_{ijk})}$  by  $\tilde{Z}$ . It can be easily checked by computer that the following inequalities hold for every  $\tilde{\zeta}_{ijk}^{(n_{ijk})} = (\tilde{\zeta}_1^*, \tilde{\zeta}_2^*, \tilde{\zeta}_3^*) \in \tilde{Z}$ :

$$-316.6 \delta < \tilde{\zeta}_1^* < 316.74 \delta, \quad -11.17 \delta < \tilde{\zeta}_2^* < 11.49 \delta, \quad -15.70 \delta < \tilde{\zeta}_3^* < 15.25 \delta.$$

(The range of all projections of numerical trajectories  $\tilde{\zeta}_{ijk}^{(n_{ijk})} = (\tilde{\zeta}_1^*, \tilde{\zeta}_2^*, \tilde{\zeta}_3^*)$  to the hyperplane  $\Sigma^{(m)}$ ,  $m = 1, 2, \dots, 23$ , is provided in Table 1.)

It follows then from estimate (3.11) and the inequalities

$$\begin{aligned} |z_1^*| &< \left| z_1^* - \tilde{\zeta}_1^* \right| + \left| \tilde{\zeta}_1^* \right| < \varepsilon + 316.74 \delta < 322 \delta, \\ |z_2^*| &< \left| z_2^* - \tilde{\zeta}_2^* \right| + \left| \tilde{\zeta}_2^* \right| < \varepsilon + 11.49 \delta < 16 \delta, \\ |z_3^*| &< \left| z_3^* - \tilde{\zeta}_3^* \right| + \left| \tilde{\zeta}_3^* \right| < \varepsilon + 15.70 \delta < 21 \delta, \end{aligned}$$

that (Fig. 3)

$$S^\omega \subset \text{Int } S^{(1)},$$

where  $(z_1^*, z_2^*, z_3^*) = z_{uvw}(t_{uvw}) - z_0^{(1)}$ .

Therefore, it follows from Brouwer's fixed point theorem [23] that the map  $\Phi$  has a fixed point  $z^* \in S^{(1)}$  that is  $\Phi(z^*) = z^*$  and therefore, the trajectory passing through this point will be closed.

Applying the DN-tracking method for each fixed value of  $\tilde{\beta} \in (0.431, 1.173)$ , one can prove the following theorem.

**Theorem 6.** For  $\tilde{\beta} \in (0.431, 1.173)$ , system (2.1) has a closed trajectory.

#### 4. Conclusion

In the present paper, a Brusselator model has been studied. The main contribution of the paper is as follows:

- (1) a new modified four-dimensional Brusselator model, having cyclical property, has been proposed;
- (2) the existence of a closed trajectory for this model has been established.

To prove the existence of a closed trajectory, the DN-tracking method has been applied.

#### REFERENCES

1. Adomian G. The diffusion Brusselator equation. *Comput. Math. Appl.*, 1995. Vol. 29, No. 5. P. 1–3. DOI: [10.1016/0898-1221\(94\)00244-F](https://doi.org/10.1016/0898-1221(94)00244-F)
2. Alqahtani A.M. Numerical simulation to study the pattern formation of reaction–diffusion Brusselator model arising in triple collision and enzymatic. *J. Math. Chem.*, 2018. Vol. 56. P. 1543–1566. DOI: [10.1007/s10910-018-0859-8](https://doi.org/10.1007/s10910-018-0859-8)
3. Azamov A. A. DN-tracking method for proving the existence of limit cycles. In: *Abstr. of the Int. Conf. Differential Equations and Topology dedicated to the Centennial Anniversary of L.S. Pontryagin, June 17–22, 2008, Moscow, Russia*. Moscow: MSU, 2008. P. 87–88. (in Russian)
4. Azamov A. A., Ibragimov G., Akhmedov O. S., Ismail F. On the proof of existence of a limit cycle for the Prigogine brusselator model. *J. Math. Res.*, 2011. Vol. 3, No. 4. P. 983–989. DOI: [10.5539/jmr.v3n4p93](https://doi.org/10.5539/jmr.v3n4p93)
5. Azamov A. A., Akhmedov O. S. Existence of a complex closed trajectory in a three-dimensional dynamical system. *Comput. Math. Math. Phys.*, 2011. Vol. 51, No. 8. P. 1353–1359. DOI: [10.1134/S0965542511080033](https://doi.org/10.1134/S0965542511080033)
6. Azamov A. A., Akhmedov O. S. On existence of a closed trajectory in a three-dimensional model of a Brusselator. *Mech. Solids*, 2019. Vol. 54, No. 2. P. 251–265. DOI: [10.3103/S0025654419030038](https://doi.org/10.3103/S0025654419030038)
7. Bakhvalov N. S. *CHislennye metody* [Numerical methods]. Moscow: Mir, 1977. (in Russian)
8. Boldo S., Faissole F., Chapoutot A. Round-off error analysis of explicit one-step numerical integration methods. In: *IEEE 24th Symposium on Computer Arithmetic (ARITH), July 24–26, 2017, London, UK*. IEEE Xplore, 2017. P. 82–89. DOI: [10.1109/ARITH.2017.22](https://doi.org/10.1109/ARITH.2017.22)
9. Butcher J. C. *Numerical Methods for Ordinary Differential Equations*, 3rd ed. New York: John Wiley & Sons Ltd., 2016. 538 p.
10. Cartan H. *Calcul Différentiel. Formes Différentielles*. Paris: Hermann, 1967.

11. Elyukhina I. Nonlinear stability analysis of the full Brusselator reaction–diffusion model. *Theor. Found. Chem. Eng.*, 2014. Vol. 48, No. 6. P. 806–812. DOI: [10.1134/S0040579514060025](https://doi.org/10.1134/S0040579514060025)
12. Glansdorff P., Prigogine I. *Thermodynamic Theory of Structure, Stability and Fluctuations*. New York: John Wiley & Sons Ltd., 1971.
13. Guckenheimer J. Dynamical systems theory for ecologists: a brief overview. In: *Ecological Time Series*. Boston, MA: Springer, 1995. P. 54–69. DOI: [10.1007/978-1-4615-1769-6\\_6](https://doi.org/10.1007/978-1-4615-1769-6_6)
14. Hairer E., Nørsett S., Wanner G. *Solving Ordinary Differential Equations I. Non-stiff Problems*. Springer Ser. Comput. Math., vol. 8. Berlin, Heidelberg: Springer-Verlag, 1993. 528 p.
15. Holmes M.H. *Introduction to Numerical Methods in Differential Equations*. Texts Appl. Math., vol. 52. New York: Springer-Verlag, 2007. 239 p. DOI: [10.1007/978-0-387-68121-4](https://doi.org/10.1007/978-0-387-68121-4)
16. Kehlet B., Logg A. A posteriori error analysis of round-off errors in the numerical solution of ordinary differential equation. *Numer. Algorithms*, 2017. Vol. 76. P. 191–210. DOI: [10.1007/s11075-016-0250-4](https://doi.org/10.1007/s11075-016-0250-4)
17. Li Y. Hopf bifurcations in general systems of Brusselator type. *Nonlinear Anal. Real World Appl.*, 2016. Vol. 28. P. 32–47. DOI: [10.1016/j.nonrwa.2015.09.004](https://doi.org/10.1016/j.nonrwa.2015.09.004)
18. Ma M., Hu J. Bifurcation and stability analysis of steady states to a Brusselator model. *Appl. Math. Comput.*, 2014. Vol. 236. P. 580–592. DOI: [10.1016/j.amc.2014.02.075](https://doi.org/10.1016/j.amc.2014.02.075)
19. Ma S.J. The stochastic Hopf bifurcation analysis in Brusselator system with random parameter. *Appl. Math. Comput.*, 2012. Vol. 219. P. 306–319. DOI: [10.1016/j.amc.2012.06.021](https://doi.org/10.1016/j.amc.2012.06.021)
20. Nicolis G., Prigogine I. *Self-Organization in Nonequilibrium Systems*. New York: John Wiley & Sons Ltd., 1977. 491 p.
21. Nikol'skii M. S. *Pervyj pryamoj metod L.S. Pontryagina v differencial'nyh igrakh* [Pontryagin's First Direct Method for Differential Games]. Moscow: Moscow State Univ., 1984. 65 p. (in Russian)
22. Peña B., Pérez-García C. Stability of Turing patterns in the Brusselator model. *Phys. Rev. E*, 2001. Vol. 64. P. 156–213. DOI: [10.1103/PhysRevE.64.056213](https://doi.org/10.1103/PhysRevE.64.056213)
23. Pontryagin L.S. *Foundations of Combinatorial Topology*. Rochester, New York: Graylock press, 1952. 99 p.
24. Prigogine I., Lefever R. Symmetry breaking instabilities in dissipative systems II. *J. Chem. Phys.*, 1968. Vol. 48, No. 4. P. 1695–1700. DOI: [10.1063/1.1668896](https://doi.org/10.1063/1.1668896)
25. Prigogine I. *From Being to Becoming: Time and Complexity in the Physical Sciences*. New York, San Francisco: W.H. Freeman & Co. Ltd, 1980. 272 p.
26. Rubido N. Stochastic dynamics and the noisy Brusselator behaviour. 2014. P. 1–7. [arXiv: 1405.0390](https://arxiv.org/abs/1405.0390) [cond-mat.stat-mech]
27. Tucker W. A rigorous ODE solver and Smale's 14th problem. *Found. Comput. Math.*, 2002. Vol. 2. P. 53–117. DOI: [10.1007/s002080010018](https://doi.org/10.1007/s002080010018)
28. Twizell E.H., Gumel A.B., Cao Q. A second-order scheme for the “Brusselator” reaction–diffusion system. *J. Math. Chem.*, 1999. Vol. 26. P. 297–316. DOI: [10.1023/A:1019158500612](https://doi.org/10.1023/A:1019158500612)
29. Tyson J.J. Some further studies of nonlinear oscillations in chemical systems. *J. Chem. Phys.*, 1973. Vol. 58. P. 3919–3930. DOI: [10.1063/1.1679748](https://doi.org/10.1063/1.1679748)
30. Tzou J.C., Ward M.J. The stability and slow dynamics of spot patterns in the 2D Brusselator model: The effect of open systems and heterogeneities. *Phys. D: Nonlinear Phenomena*, 2018. Vol. 373. P. 13–37. DOI: [10.1016/j.physd.2018.02.002](https://doi.org/10.1016/j.physd.2018.02.002)
31. You Y. Global dynamics of the Brusselator equations. *Dyn. Partial Differ. Equ.*, 2007. Vol. 4, No. 2. P. 167–196. DOI: [10.4310/DPDE.2007.v4.n2.a4](https://doi.org/10.4310/DPDE.2007.v4.n2.a4)
32. You Y., Zhou Sh. Global dissipative dynamics of the extended Brusselator system. *Nonlinear Anal. Real World Appl.*, 2012. Vol. 13, No. 6. P. 2767–2789. DOI: [10.1016/j.nonrwa.2012.04.005](https://doi.org/10.1016/j.nonrwa.2012.04.005)
33. Yu P., Gumel A.B. Bifurcation and stability analysis for a coupled Brusselator model. *J. Sound and Vibration*, 2001. Vol. 244, No. 5. P. 795–820. DOI: [10.1006/jsvi.2000.3535](https://doi.org/10.1006/jsvi.2000.3535)
34. Zhao Z., Ma R. Local and global bifurcation of steady states to a general Brusselator model. *Adv. Differ. Equ.*, 2019. Art. No. 491. P. 1–14. DOI: [10.1186/s13662-019-2426-4](https://doi.org/10.1186/s13662-019-2426-4)

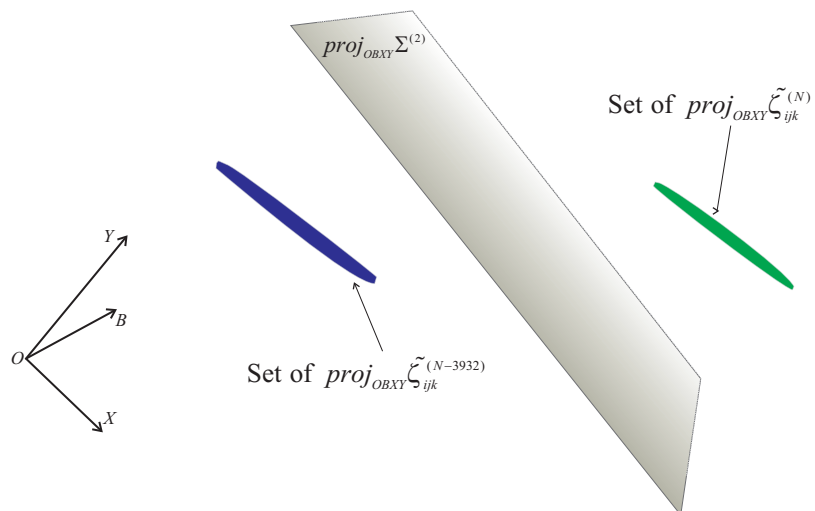

Figure 1. Parallel projection set of points  $\tilde{\zeta}_{ijk}^{(N-3932)}$  and  $\tilde{\zeta}_{ijk}^{(N)}$  onto the space  $OBY$  with parallel projection direction which is perpendicular to the normal  $f(z_0^{(2)})$ .

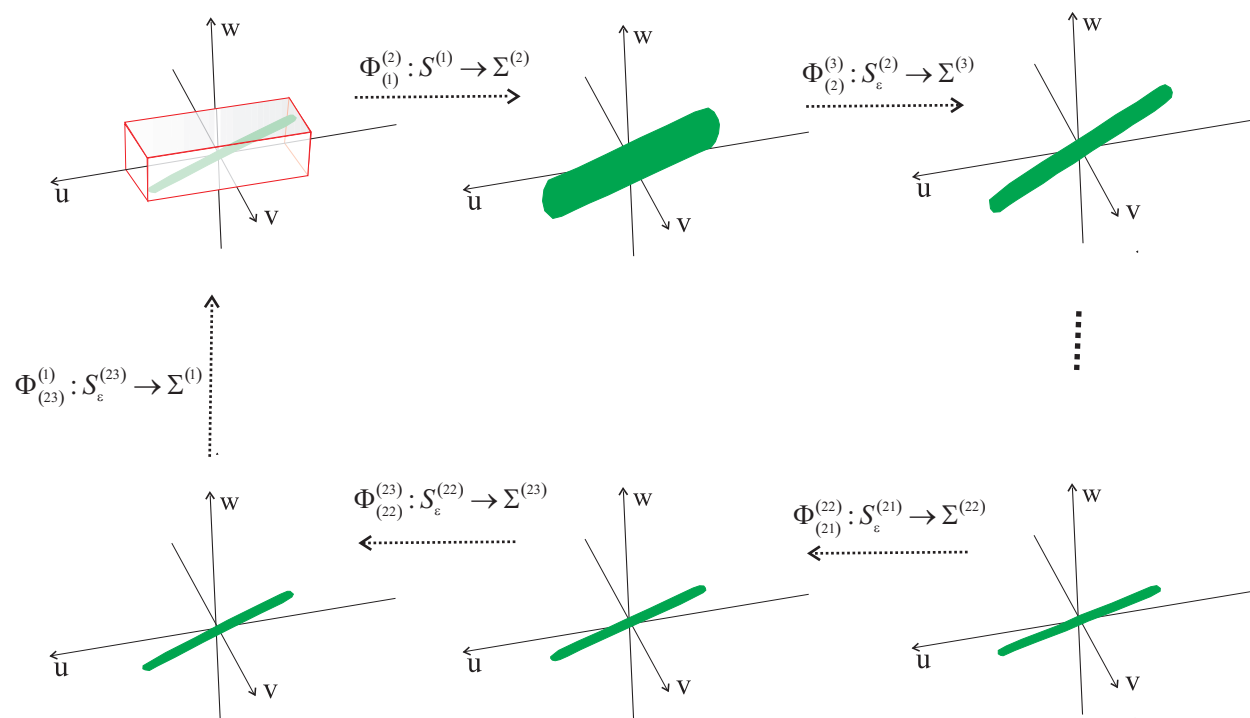

Figure 2. Some components of the Poincaré map. Scale  $u:v:w=1:5:5$ .

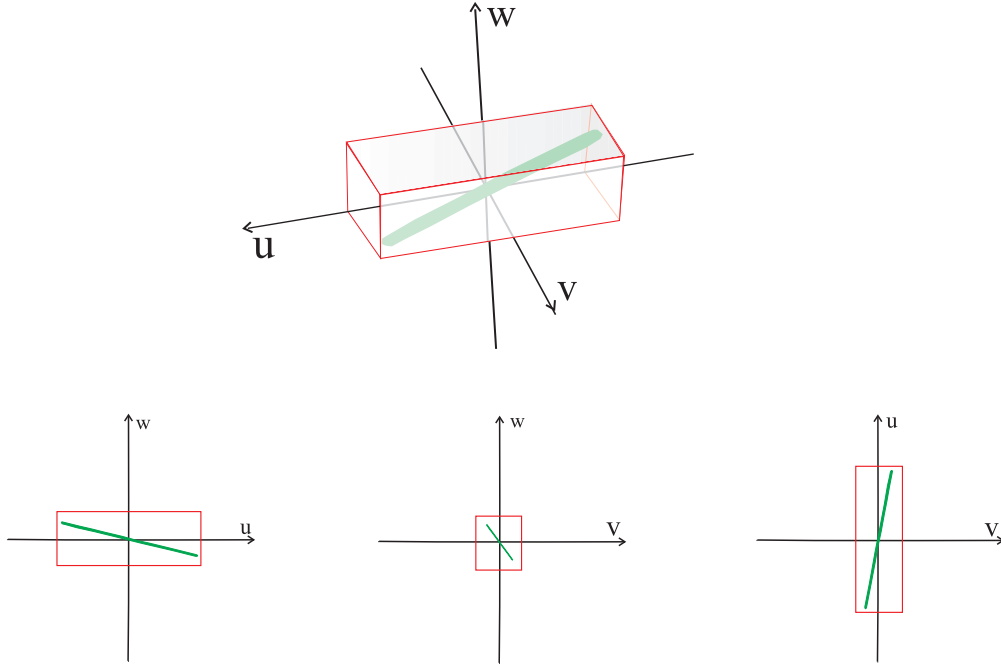

Figure 3. Poincaré map  $\Phi : S^{(1)} \rightarrow \Sigma^{(1)}$  in axonometric and 2d-projections. Scale  $u:v:w=1:5:5$ .

Table 1. The range of all orthogonal projections of numerical trajectories  $\tilde{\zeta}_{ijk}^{(n_{ijk})}$  to the hyperplane  $\Sigma^{(m)}$ .

<b>m</b>	$\min \zeta_1^*$	$\max \zeta_1^*$	$\min \zeta_2^*$	$\max \zeta_2^*$	$\min \zeta_3^*$	$\max \zeta_3^*$
<b>1</b>	$-325\delta$	$325\delta$	$-20\delta$	$20\delta$	$-25\delta$	$25\delta$
<b>2</b>	$-346.69\delta$	$347\delta$	$-28.58\delta$	$28.56\delta$	$-29.28\delta$	$29.39\delta$
<b>3</b>	$-378.63\delta$	$379.78\delta$	$-30.23\delta$	$30.06\delta$	$-35.87\delta$	$36.01\delta$
<b>4</b>	$-437.25\delta$	$440.32\delta$	$-33.60\delta$	$33.39\delta$	$-44.64\delta$	$44.70\delta$
<b>5</b>	$-538.99\delta$	$546.29\delta$	$-44.24\delta$	$44.24\delta$	$-55.30\delta$	$55.16\delta$
<b>6</b>	$-714.57\delta$	$729.62\delta$	$-70.09\delta$	$70.86\delta$	$-63.22\delta$	$62.94\delta$
<b>7</b>	$-977.87\delta$	$989.04\delta$	$-117.06\delta$	$117.88\delta$	$-42.42\delta$	$43.18\delta$
<b>8</b>	$-1090.88\delta$	$1087.21\delta$	$-122.66\delta$	$122.04\delta$	$-38.73\delta$	$38.60\delta$
<b>9</b>	$-890.64\delta$	$896.91\delta$	$-56.55\delta$	$56.70\delta$	$-72.00\delta$	$72.36\delta$
<b>10</b>	$-704.54\delta$	$705.84\delta$	$-14.71\delta$	$14.53\delta$	$-56.05\delta$	$56.24\delta$
<b>11</b>	$-599.26\delta$	$597.09\delta$	$-8.01\delta$	$8.01\delta$	$-35.44\delta$	$35.46\delta$
<b>12</b>	$-552.71\delta$	$549.30\delta$	$-14.02\delta$	$13.90\delta$	$-17.81\delta$	$17.87\delta$
<b>13</b>	$-552.12\delta$	$548.61\delta$	$-18.26\delta$	$18.16\delta$	$-2.43\delta$	$2.61\delta$
<b>14</b>	$-600.14\delta$	$597.67\delta$	$-20.19\delta$	$20.00\delta$	$-12.66\delta$	$12.99\delta$
<b>15</b>	$-716.87\delta$	$717.77\delta$	$-18.51\delta$	$18.12\delta$	$-31.28\delta$	$31.71\delta$
<b>16</b>	$-928.67\delta$	$932.88\delta$	$-7.67\delta$	$7.77\delta$	$-55.90\delta$	$56.48\delta$
<b>17</b>	$-1066.81\delta$	$1063.65\delta$	$-43.75\delta$	$43.42\delta$	$-56.06\delta$	$56.34\delta$
<b>18</b>	$-821.69\delta$	$837.41\delta$	$-54.46\delta$	$54.83\delta$	$-17.07\delta$	$16.16\delta$
<b>19</b>	$-583.27\delta$	$592.99\delta$	$-38.93\delta$	$39.02\delta$	$-1.67\delta$	$1.35\delta$
<b>20</b>	$-450.01\delta$	$454.21\delta$	$-27.18\delta$	$27.05\delta$	$-0.84\delta$	$0.69\delta$
<b>21</b>	$-378.01\delta$	$379.81\delta$	$-19.75\delta$	$19.57\delta$	$-3.14\delta$	$3.07\delta$
<b>22</b>	$-340.45\delta$	$341.26\delta$	$-15.07\delta$	$14.90\delta$	$-7.40\delta$	$7.38\delta$
<b>23</b>	$-325.12\delta$	$325.59\delta$	$-12.38\delta$	$12.23\delta$	$-12.63\delta$	$12.64\delta$



# ESTIMATES OF BEST APPROXIMATIONS OF FUNCTIONS WITH LOGARITHMIC SMOOTHNESS IN THE LORENTZ SPACE WITH ANISOTROPIC NORM<sup>1</sup>

Gabdolla Akishev

L.N. Gumilyov Eurasian National University,  
2 Pushkin str., Nur-Sultan, 010008, Kazakhstan

Ural Federal University,  
19 Mira str., Ekaterinburg, 620002, Russia

akishev\_g@mail.ru

**Abstract:** In this paper, we consider the anisotropic Lorentz space  $L_{\bar{p},\bar{\theta}}^*(\mathbb{I}^m)$  of periodic functions of  $m$  variables. The Besov space  $B_{\bar{p},\bar{\theta}}^{(0,\alpha,\tau)}$  of functions with logarithmic smoothness is defined. The aim of the paper is to find an exact order of the best approximation of functions from the class  $B_{\bar{p},\bar{\theta}}^{(0,\alpha,\tau)}$  by trigonometric polynomials under different relations between the parameters  $\bar{p}, \bar{\theta}$ , and  $\tau$ .

The paper consists of an introduction and two sections. In the first section, we establish a sufficient condition for a function  $f \in L_{\bar{p},\bar{\theta}(1)}^*(\mathbb{I}^m)$  to belong to the space  $L_{\bar{p},\bar{\theta}(2)}^*(\mathbb{I}^m)$  in the case  $1 < \theta^2 < \theta_j^{(1)}$ ,  $j = 1, \dots, m$ , in terms of the best approximation and prove its unimprovability on the class  $E_{\bar{p},\bar{\theta}}^\lambda = \{f \in L_{\bar{p},\bar{\theta}}^*(\mathbb{I}^m) : E_n(f)_{\bar{p},\bar{\theta}} \leq \lambda_n, n = 0, 1, \dots\}$ , where  $E_n(f)_{\bar{p},\bar{\theta}}$  is the best approximation of the function  $f \in L_{\bar{p},\bar{\theta}}^*(\mathbb{I}^m)$  by trigonometric polynomials of order  $n$  in each variable  $x_j$ ,  $j = 1, \dots, m$ , and  $\lambda = \{\lambda_n\}$  is a sequence of positive numbers  $\lambda_n \downarrow 0$  as  $n \rightarrow +\infty$ . In the second section, we establish order-exact estimates for the best approximation of functions from the class  $B_{\bar{p},\bar{\theta}(1)}^{(0,\alpha,\tau)}$  in the space  $L_{\bar{p},\bar{\theta}(2)}^*(\mathbb{I}^m)$ .

**Key words:** Lorentz space, Nikol’skii–Besov class, Best approximation.

## 1. Introduction

Let  $\bar{x} = (x_1, \dots, x_m) \in \mathbb{R}^m$ ,  $\mathbb{I}^m = [0, 2\pi]^m$ ,  $\bar{p} = (p_1, \dots, p_m)$ , and  $\bar{\theta} = (\theta_1, \dots, \theta_m)$ , where  $p_j \in (1, \infty)$  and  $\theta_j \in [1, \infty)$  for  $j = 1, 2, \dots, m$ . Denote by  $L_{\bar{p},\bar{\theta}}^*(\mathbb{I}^m)$  the Lorentz space of real-valued functions  $f(\bar{x})$  that are  $2\pi$ -periodic in each variable and

$$\|f\|_{\bar{p},\bar{\theta}}^* = \left\{ \int_0^{2\pi} t_m^{\frac{\theta_m}{p_m}-1} \left[ \dots \left[ \int_0^{2\pi} (f^{*1,\dots,*m}(t_1, \dots, t_m))^{\theta_1} t_1^{\frac{\theta_1}{p_1}-1} dt_1 \right]^{\frac{\theta_2}{p_2}} \dots \right]^{\frac{\theta_m}{p_m}} dt_m \right\}^{1/\theta_m} < +\infty,$$

where  $f^{*1,\dots,*m}$  is a nonincreasing rearrangement of the function  $|f(x_1, \dots, x_m)|$  in each of the variables  $x_j$  whereas the other variables are fixed (see [8, 18]).

In the case  $p_1 = \dots = p_m = \theta_1 = \dots = \theta_m = p$ , the Lorentz space  $L_{\bar{p},\bar{\theta}}^*(\mathbb{I}^m)$  coincides with the Lebesgue space  $L_p(\mathbb{I}^m)$  with the norm

$$\|f\|_p = \left[ \int_0^{2\pi} \dots \int_0^{2\pi} |f(x_1, \dots, x_m)|^p dx_1 \dots dx_m \right]^{1/p},$$

---

<sup>1</sup>This work was supported by the Competitiveness Enhancement Program of the Ural Federal University (Enactment of the Government of the Russian Federation of March 16, 2013 no. 211, agreement no. 02.A03.21.0006 of August 27, 2013).

where  $p \in [1, +\infty)$ .

Instead of  $L_{\bar{p}, \bar{\theta}}^*(\mathbb{I}^m)$ , we will write  $L_{p, \theta}^*(\mathbb{I}^m)$  in the case  $p_1 = \dots = p_m = p$  and  $\theta_1 = \dots = \theta_m = \theta$  and  $L_{\bar{p}, \theta^{(2)}}^*(\mathbb{I}^m)$  if  $\bar{p} = (p_1, \dots, p_m)$  and  $\theta_1 = \dots = \theta_m = \theta^{(2)}$ .

Given a natural number  $M$ , consider the set

$$\square_M = \{\bar{k} = (k_1, \dots, k_m) \in \mathbb{Z}^m : |k_j| < M, j = 1, \dots, m\}.$$

Consider the multiple Dirichlet kernel

$$D_{\square_M}(\bar{x}) = \sum_{\bar{k} \in \square_M} e^{i\langle \bar{k}, \bar{x} \rangle}, \quad \bar{x} \in \mathbb{I}^m,$$

and its convolution with a function  $f \in L_{\bar{p}, \bar{\theta}}^*(\mathbb{I}^m)$ :

$$\sigma_s(f, \bar{x}) = \int_{\mathbb{I}^m} f(\bar{y})(D_{\square_{2^s}}(\bar{x} - \bar{y}) - D_{\square_{2^{s-1}}}(\bar{x} - \bar{y}))d\bar{y},$$

where  $s \in \mathbb{N}_0 = \mathbb{N} \cup \{0\}$  and  $\mathbb{N}$  is the set of positive integers.

Let  $M \in \mathbb{N}_0$ , and let  $T_M(\bar{x}) = \sum_{\bar{k} \in \square_M} a_{\bar{k}} e^{i\langle \bar{k}, \bar{x} \rangle}$  be a trigonometric polynomial of order  $M$  in each variable  $x_j$ ,  $j = 1, \dots, m$ . Denote by  $\mathfrak{F}_{\square_M}$  the set of all such polynomials.

Let  $E_{M, \dots, M}(f)_{\bar{p}, \bar{\theta}} = \inf_{T \in \mathfrak{F}_{\square_M}} \|f - T\|_{\bar{p}, \bar{\theta}}^*$  be the best approximation of a function  $f \in L_{\bar{p}, \bar{\theta}}^*(\mathbb{I}^m)$  by the set  $\mathfrak{F}_{\square_M}$ . Sometimes, we will use the notation  $E_M(f)_{\bar{p}, \bar{\theta}}$  instead of  $E_{M, \dots, M}(f)_{\bar{p}, \bar{\theta}}$ . For a given class  $F \subset L_{\bar{p}, \bar{\theta}}^*(\mathbb{I}^m)$ , let  $E_M(F)_{\bar{p}, \bar{\theta}} = \sup_{f \in F} E_M(f)_{\bar{p}, \bar{\theta}}$ .

Let  $\alpha \geq 0$ ,  $\gamma \in (-\infty, +\infty)$ , and  $0 < \tau < \infty$ . Denote by  $\mathbb{A}_{\bar{p}, \bar{\theta}}^{(\alpha, \gamma, \tau)}$  the space of all functions  $f \in L_{\bar{p}, \bar{\theta}}^*(\mathbb{I}^m)$  such that the quasi-norm (see [9, 20])

$$\|f\|_{\mathbb{A}_{\bar{p}, \bar{\theta}}^{(\alpha, \gamma, \tau)}} = \left[ \sum_{n=1}^{\infty} n^{-1} (n^\alpha (1 + \log n)^\gamma E_n(f)_{\bar{p}, \bar{\theta}})^\tau \right]^{1/\tau}$$

is finite, where  $\log a$  is the logarithm of the number  $a$  to the base 2.

If  $\tau = \infty$ , then

$$\|f\|_{\mathbb{A}_{\bar{p}, \bar{\theta}}^{\alpha, \gamma, \tau}} = \sup_{n \geq 1} n^\alpha (1 + \log n)^\gamma E_n(f)_{\bar{p}, \bar{\theta}} < \infty.$$

It is known that  $\mathbb{A}_{\bar{p}, \bar{\theta}}^{(\alpha, \gamma, \tau)}$  is a quasi-Banach space (see [9, 10, 20]). It is called an approximate space (see [11]).

In the anisotropic Lorentz space, we consider the space  $B_{\bar{p}, \bar{\theta}}^{(0, \alpha, \tau)}$ ,  $1 \leq \tau \leq \infty$ , of all functions  $f \in L_{\bar{p}, \bar{\theta}}^*(\mathbb{I}^m)$  representable in the form of series

$$\sum_{n=0}^{\infty} Q_{2^{2n}}(f, \bar{x}), \quad Q_{2^{2n}}(f) \in \mathfrak{F}_{\square_{2^{2n}}} \tag{1.1}$$

and such that

$$\left[ \sum_{n=0}^{\infty} (2^{n\alpha} \|Q_{2^{2n}}(f)\|_{\bar{p}, \bar{\theta}}^*)^\tau \right]^{1/\tau} < +\infty \tag{1.2}$$

for  $1 \leq \tau < \infty$  and

$$\sup_{n \in \mathbb{N}_0} 2^{n\alpha} \|Q_{2^{2n}}(f)\|_{\bar{p}, \bar{\theta}}^* < \infty$$

for  $\tau = \infty$ . The infimum of expression (1.2) over all representations (1.1) defines a quasi-norm in this space:

$$\|f\|_{B_{\bar{p},\bar{\theta}}^{(0,\alpha,\tau)}} = \inf \left[ \sum_{n=0}^{\infty} (2^{n\alpha} \|Q_{2^{2n}}(f)\|_{\bar{p},\bar{\theta}}^*)^\tau \right]^{1/\tau}.$$

The space  $B_{\bar{p},\bar{\theta}}^{(0,\alpha,\tau)}$  is called the Besov space with logarithmic smoothness. In  $B_{\bar{p},\bar{\theta}}^{(0,\alpha,\tau)}$ , we consider the unit ball

$$\mathbb{B}_{\bar{p},\bar{\theta}}^{(0,\alpha,\tau)} = \left\{ f \in L_{\bar{p},\bar{\theta}}^*(\mathbb{I}^m) : \|f\|_{B_{\bar{p},\bar{\theta}}^{(0,\alpha,\tau)}} \leq 1 \right\}.$$

It is known that  $f \in \mathbb{B}_{\bar{p},\bar{\theta}}^{(0,\gamma+1/\tau,\tau)}$  if and only if  $f \in \mathbb{A}_{\bar{p},\bar{\theta}}^{(0,\gamma,\tau)}$  (see [10]).

The main aim of the present paper is to obtain an exact order of the best approximation of the function classes  $\mathbb{A}_{\bar{p},\bar{\theta}^{(1)}}^{(0,\gamma,\tau)}$  and  $\mathbb{B}_{\bar{p},\bar{\theta}^{(1)}}^{(0,\gamma,\tau)}$  in anisotropic Lorentz spaces.

In the one-dimensional case, sufficient conditions for a function  $f \in L_p(I^1)$  to belong to the space  $L_q(\mathbb{I}^1)$  for  $1 \leq p < q < \infty$  in terms of the best approximation and the modulus of continuity were established by P.L. Ul'ynov [30]. This study was continued by V.I. Kolyada [15], V.A. Andrienko [5], N. Temirgaliev [27, 28], E.A. Storozhenko [26], M.F. Timan, P. Oswald, L. Leindler, S.V. Lapin, B.V. Simonov, and others (see the references in [16]).

N. Temirgaliev established [28] a necessary and sufficient condition for a univariate function  $f \in L_p(\mathbb{I}^1)$  to belong to the Lorentz space  $L_{q,\theta}(\mathbb{I}^1)$  in terms of the modulus of continuity for  $1 \leq \theta < p < \infty$ . L.A. Sherstneva studied [22] this problem in terms of the best approximation of a function. Such problems in the Lorentz space were investigated in [1, 4, 23].

Problems of estimating various approximative characteristics of function classes are well known and a survey of the results on this topic is given in [12, 29]. In particular, in the Lebesgue space  $L_p(\mathbb{I}^m)$ , exact estimates of the best approximation of functions of the Besov class  $B_{\bar{p},\bar{\theta}^{(1)}}^r$  were established by A.S. Romanyuk [21]. In the case  $\theta_j^{(1)} = p_j = p$ ,  $j = 1, \dots, m$ , estimates of approximative characteristics of the class  $\mathbb{B}_{\bar{p},\bar{\theta}^{(1)}}^{0,\alpha}$  were obtained by S.A. Stasyuk [24, 25]. In [13], the embedding and characterization problems of the Besov space with logarithmic smoothness in the Lebesgue space  $L_p(\mathbb{I}^m)$  were investigated.

Exact estimates of best approximations of functions from the Besov class in the Lorentz space with a mixed norm were obtained in [2, 6, 7].

The present paper consists of the introduction and two sections. In Section 1, we establish a sufficient condition for a function  $f \in L_{\bar{p},\bar{\theta}}^*(\mathbb{I}^m)$  to belong to the space  $L_{\bar{p},\theta^{(2)}}^*(\mathbb{I}^m)$ ,  $\theta^{(2)} < \theta_j^{(1)}$ ,  $j = 1, \dots, m$ , and prove its accuracy on the class

$$E_{\bar{p},\bar{\theta}}^\lambda = \left\{ f \in L_{\bar{p},\bar{\theta}}^*(\mathbb{I}^m) : E_n(f)_{\bar{p},\bar{\theta}} \leq \lambda_n, n = 0, 1, \dots \right\},$$

where  $\lambda = \{\lambda_n\}$  is a sequence of positive numbers  $\lambda_n \downarrow 0$  as  $n \rightarrow +\infty$ .

In the case  $p_j = \theta_j = p$ ,  $j = 1, \dots, m$ , V.I. Kolyada proved [15] a necessary and sufficient condition for the embedding of classes  $E_p^\lambda$  in the space  $L_q(\mathbb{I}^1)$ ,  $1 \leq p < q$ .

In Section 2, we establish order-exact estimates of the value  $E_n(\mathbb{B}_{\bar{p},\bar{\theta}^{(1)}}^{(0,\gamma,\tau)})_{\bar{q},\bar{\theta}^{(2)}}$  under various relations between coordinates of the parameters  $\bar{p}, \bar{\theta}^{(1)}, \bar{q}, \bar{\theta}^{(2)}, \tau$  (see Theorems 5 and 6).

The notation  $A(y) \asymp B(y)$  means that there exists positive constants  $C_1$  and  $C_2$  such that  $C_1 A(y) \leq B(y) \leq C_2 A(y)$ . If  $B(y) \leq C_2 A(y)$  or  $A(y) \geq C_1 B(y)$ , then we write  $B(y) \ll A(y)$  and  $A(y) \gg B(y)$ , respectively.

## 2. Conditions for embedding classes in the Lorentz space

**Theorem 1** [19, Theorem 10]. *Let  $1 \leq p_j < +\infty$  and  $1 \leq \theta_j < q_j < +\infty$  for  $j = 1, \dots, m$ , let  $\bar{p} = (p_1, \dots, p_m)$  and  $\bar{q} = (q_1, \dots, q_m)$ , and let  $\theta = (\theta_1, \dots, \theta_m)$ . Then a trigonometric polynomial*

$$T_{\bar{n}}(\bar{x}) = \sum_{k_1=-n_1}^{n_1} \dots \sum_{k_m=-n_m}^{n_m} b_{\bar{k}} e^{i\langle \bar{x}, \bar{k} \rangle}$$

satisfies the following inequality:

$$\|T_{\bar{n}}\|_{\bar{p}, \bar{\theta}}^* \leq C(p, q, \theta) \prod_{j=1}^m (\ln(1 + n_j))^{1/\theta_j - 1/q_j} \|T_{\bar{n}}\|_{\bar{p}, \bar{q}}^*$$

**Lemma 1.** *Let  $1 < p_j < \infty$  and  $1 < q_2 < q_j^{(1)} < +\infty$  for  $j = 1, \dots, m$ . Let  $\{u_n\}$  be a sequence of non-negative measurable functions on the cube  $\mathbb{I}^m = [0, 2\pi]^m$  such that*

(1)

$$\|u_n\|_{\bar{p}, \bar{q}^{(1)}}^* \leq \varepsilon_n, \quad \varepsilon_{n+1} \leq \beta \varepsilon_n, \quad \beta \in (0, 1);$$

(2) *there exists a sequence of positive numbers  $\{\Delta_n\}$  such that*

$$\|u_n\|_{p, \theta}^* \leq C \Delta_n^{\sum_{j=1}^m (1/\theta_j - 1/q_j^{(1)})} \varepsilon_n, \quad n = 1, 2, 3, \dots,$$

for any  $\theta_j \in (0, q_j^{(1)})$ ,  $j = 1, \dots, m$ .

Then the inequality

$$\|f\|_{p, q_2}^* \leq C \left\{ \sum_{n=1}^{\infty} \Delta_n^{\sum_{j=1}^m (1/q_2 - 1/q_j^{(1)})} \varepsilon_n^{q_2} \right\}^{1/q_2}$$

holds for every function of the form  $f(\bar{x}) = \sum_{n=1}^{\infty} u_n(\bar{x})$ .

This lemma is proved by V.I. Kolyada's method (see [15, Proof of Lemma 4]) as in [3].

*Remark 1.* Lemma 1 was proved by L.A. Sherstneva [22, Lemma 13] in the one-dimensional case and by the author [3] in the multi-dimensional case for  $q_1^{(1)} = \dots = q_m^{(1)}$ .

Now, let us consider a condition for a function  $f \in L_{\bar{p}, \bar{\theta}^{(1)}}^*(\mathbb{I}^m)$  to belong to the space  $L_{\bar{p}, \theta^{(2)}}^*(\mathbb{I}^m)$ ,  $1 < \theta^{(2)} < \theta_j^{(1)} < +\infty$ ,  $j = 1, \dots, m$ .

**Theorem 2.** *Let  $1 < \theta^{(2)} < \theta_j^{(1)} < +\infty$  and  $1 < p_j < \infty$  for  $j = 1, \dots, m$ , and let  $\bar{\theta}^{(1)} = (\theta_1^{(1)}, \dots, \theta_m^{(1)})$ . Assume that  $f \in L_{\bar{p}, \bar{\theta}^{(1)}}^*(\mathbb{I}^m)$  and*

$$\sum_{n=2}^{\infty} \frac{(\ln n)^{\theta^{(2)} \sum_{j=1}^m (1/\theta^{(2)} - 1/\theta_j^{(1)}) - 1}}{n} E_{n, \dots, n}^{\theta^{(2)}}(f)_{\bar{p}, \bar{\theta}^{(1)}} < +\infty. \quad (2.1)$$

Then  $f \in L_{\bar{p}, \theta^{(2)}}^*(\mathbb{I}^m)$  and

$$\|f\|_{\bar{p}, \theta^{(2)}}^* \ll \left\{ \|f\|_{\bar{p}, \theta^{(1)}}^* + \left[ \sum_{k=2}^{\infty} \frac{(\ln(k+1))^{\theta^{(2)} \sum_{j=1}^m (1/\theta^{(2)} - 1/\theta_j^{(1)}) - 1}}{k} E_{k, \dots, k}^{\theta^{(2)}}(f)_{\bar{p}, \bar{\theta}^{(1)}} \right]^{1/\theta^{(2)}} \right\}, \quad (2.2)$$

$$\begin{aligned}
E_{n,\dots,n}(f)_{\bar{p},\theta^{(2)}} &<< \left\{ (\ln(n+1))^{\sum_{j=1}^m (1/\theta^{(2)} - 1/\theta_j^{(1)})} E_{n,\dots,n}(f)_{\bar{p},\bar{\theta}^{(1)}} + \right. \\
&+ \left. \left[ \sum_{k=n+1}^{\infty} \frac{(\ln(k+1))^{\theta^{(2)} \sum_{j=1}^m (1/\theta^{(2)} - 1/\theta_j^{(1)}) - 1}}{k} E_{k,\dots,k}^{\theta^{(2)}}(f)_{\bar{p},\bar{\theta}^{(1)}} \right]^{1/\theta^{(2)}} \right\}. \tag{2.3}
\end{aligned}$$

**P r o o f.** Since  $E_{n,\dots,n}(f)_{\bar{p},\bar{\theta}^{(1)}} \equiv \varepsilon_n \downarrow 0$  as  $n \rightarrow +\infty$  for every function  $f \in L_{\bar{p},\bar{\theta}^{(1)}}^*(\mathbb{I}^m)$ ,  $1 < p_j, \theta_j^{(1)} < +\infty$ ,  $j = 1, \dots, m$ , there exists a numerical sequence  $\{n_\nu\}$  such that (see [15, Sect. 2])

$$\varepsilon_{n_{\nu+1}} < \frac{1}{2}\varepsilon_{n_\nu}, \quad \varepsilon_{n_{\nu+1}-1} \geq \frac{1}{2}\varepsilon_{n_\nu}, \quad \nu = 1, 2, \dots$$

Let  $T_n(f, \bar{x})$  be a trigonometric polynomial of the best approximation of a function  $f \in L_{\bar{p},\bar{\theta}^{(1)}}^*(\mathbb{I}^m)$ ,  $1 < p_j, \theta_j^{(1)} < +\infty$ ,  $j = 1, \dots, m$ . Consider the series

$$T_{n_1}(f, \bar{x}) + \sum_{\nu=1}^{\infty} (T_{n_{\nu+1}}(f, \bar{x}) - T_{n_\nu}(f, \bar{x})). \tag{2.4}$$

Let us prove the convergence of this series in the norm of the space  $L_{\bar{p},\theta^{(2)}}^*(\mathbb{I}^m)$ . Suppose that

$$u_\nu(\bar{x}) = |T_{n_{\nu+1}}(f, \bar{x}) - T_{n_\nu}(f, \bar{x})|, \quad \nu = 0, 1, \dots$$

Then

$$\|u_\nu\|_{\bar{p},\bar{\theta}^{(1)}}^* \leq 2\varepsilon_\nu, \quad \nu = 0, 1, \dots,$$

and, by Theorem 1,

$$\|u_\nu\|_{\bar{p},\bar{\tau}}^* << (\ln n_{\nu+1})^{\sum_{j=1}^m (1/\tau_j - 1/\theta_j^{(1)})} \varepsilon_\nu$$

for any  $\tau_j \in (0, \theta_j^{(1)})$ ,  $j = 1, \dots, m$ . Hence, by Lemma 1, we obtain

$$\begin{aligned}
\left\| \sum_{\nu=k+1}^l (T_{n_{\nu+1}}(f) - T_{n_\nu}(f)) \right\|_{\bar{p},\theta^{(2)}}^* &\leq \left\| \sum_{\nu=k+1}^l u_\nu \right\|_{\bar{p},\theta^{(2)}}^* << \\
&<< \left\{ \sum_{\nu=k+1}^l (\ln n_{\nu+1})^{\theta^{(2)} \sum_{j=1}^m (1/\theta^{(2)} - 1/\theta_j^{(1)})} \varepsilon_\nu^{\theta^{(2)}} \right\}^{1/\theta^{(2)}}. \tag{2.5}
\end{aligned}$$

Condition (2.1) implies that

$$\sum_{\nu=1}^{\infty} (\ln n_{\nu+1})^{\theta^{(2)} \sum_{j=1}^m (1/\theta^{(2)} - 1/\theta_j^{(1)})} \varepsilon_{n_\nu}^{\theta^{(2)}} < +\infty. \tag{2.6}$$

It follows from (2.5) and (2.6) that series (2.4) converges to a function  $g \in L_{\bar{p},\theta^{(2)}}^*(\mathbb{I}^m)$  in the norm. It is easy to see that  $g(\bar{x}) = f(\bar{x})$  almost everywhere on  $\mathbb{I}^m$ . Hence,  $f \in L_{\bar{p},\theta^{(2)}}^*(\mathbb{I}^m)$ . Setting  $k = 0$  in (2.5), we get

$$\|T_{n_{l+1}}(f)\|_{\bar{p},\theta^{(2)}}^* << \left[ \|f\|_{\bar{p},\bar{\theta}^{(1)}}^* + \sum_{\nu=1}^l (\ln n_{\nu+1})^{\theta^{(2)} \sum_{j=1}^m (1/\theta^{(2)} - 1/\theta_j^{(1)})} \varepsilon_\nu^{\theta^{(2)}} \right]^{1/\theta^{(2)}} <<$$

$$\ll \left\{ \|f\|_{\bar{p}, \bar{\theta}^{(1)}}^* + \left[ \sum_{n=2}^{\infty} \frac{(\ln(n+1))^{\theta^{(2)} \sum_{j=1}^m (1/\theta^{(2)} - 1/\theta_j^{(1)}) - 1}}{n} E_{n, \dots, n}^{\theta^{(2)}}(f)_{\bar{p}, \bar{\theta}^{(1)}} \right]^{1/\theta^{(2)}} \right\}.$$

By tending  $l$  to  $+\infty$  in this inequality, we obtain

$$\|f\|_{\bar{p}, \theta^{(2)}}^* \ll \left\{ \|f\|_{\bar{p}, \bar{\theta}^{(1)}}^* + \left[ \sum_{n=2}^{\infty} \frac{(\ln(n+1))^{\theta^{(2)} \sum_{j=1}^m (1/\theta^{(2)} - 1/\theta_j^{(1)}) - 1}}{n} E_{n, \dots, n}^{\theta^{(2)}}(f)_{\bar{p}, \bar{\theta}^{(1)}} \right]^{1/\theta^{(2)}} \right\}.$$

Thus, inequality (2.2) is proved.

Applying inequality (2.2) to the function  $f - T_n(f) \in L_{\bar{p}, \theta^{(2)}}^*(\mathbb{I}^m)$ , it is easy to prove inequality (2.3). The proof of Theorem 2 is complete.  $\square$

Let us prove that condition (2.1) is exact on the classes  $E_{\bar{p}, \bar{\theta}^{(1)}}^\lambda$ .

**Theorem 3.** *Let  $1 < p_j < \infty$  and  $1 < \theta_j^{(2)} < \theta_j^{(1)} < +\infty$  for  $j = 1, \dots, m$ . The following condition is necessary and sufficient for the inclusion  $E_{\bar{p}, \bar{\theta}^{(1)}}^\lambda \subset L_{\bar{p}, \theta^{(2)}}^*(\mathbb{I}^m)$ :*

$$\sum_{n=2}^{\infty} \frac{(\ln n)^{\theta^{(2)} \sum_{j=1}^m (1/\theta^{(2)} - 1/\theta_j^{(1)}) - 1}}{n} \lambda_n^{\theta^{(2)}} < +\infty. \quad (2.7)$$

*P r o o f.* The sufficiency of condition (2.7) follows from Theorem 2. Let us prove the necessity. Let  $E_{\bar{p}, \bar{\theta}^{(1)}}^\lambda \subset L_{\bar{p}, \theta^{(2)}}^*(\mathbb{I}^m)$ . Assume that condition (2.7) is violated, i.e.,

$$\sum_{n=2}^{\infty} \frac{(\ln n)^{\theta^{(2)} \sum_{j=1}^m (1/\theta^{(2)} - 1/\theta_j^{(1)}) - 1}}{n} \lambda_n^{\theta^{(2)}} = +\infty. \quad (2.8)$$

We choose a sequence of numbers  $\{\nu_k\}$  with the following properties (see [15]):

$$\lambda_{\nu_{k+1}} < \frac{1}{2} \lambda_{\nu_k}, \quad \lambda_{\nu_{k+1}-1} \geq \frac{1}{2} \lambda_{\nu_k}. \quad (2.9)$$

Since the function  $(\ln x)^\beta/x$  with  $\beta \in \mathbb{R}$  decreases to 0 as  $x \rightarrow +\infty$ , we have

$$\begin{aligned} \sum_{n=\nu_k+1}^{\nu_{k+1}} \frac{(\ln n)^{\theta^{(2)} \sum_{j=1}^m (1/\theta^{(2)} - 1/\theta_j^{(1)}) - 1}}{n} &\leq \sum_{n=\nu_k+1}^{\nu_{k+1}} \frac{(\ln(n - \nu_k + 1))^{\theta^{(2)} \sum_{j=1}^m (1/\theta^{(2)} - 1/\theta_j^{(1)}) - 1}}{n - \nu_k} \ll \\ &\ll (\ln(\nu_{k+1} - \nu_k + 1))^{\theta^{(2)} \sum_{j=1}^m (1/\theta^{(2)} - 1/\theta_j^{(1)})}. \end{aligned}$$

Thus, (2.8) implies that

$$\sum_{k=1}^{\infty} (\ln(\nu_{k+1} - \nu_k + 1))^{\theta^{(2)} \sum_{j=1}^m (1/\theta^{(2)} - 1/\theta_j^{(1)})} \lambda_{\nu_k}^{\theta^{(2)}} = +\infty. \quad (2.10)$$

Let us consider the function

$$f_0(\bar{x}) = \sum_{k=0}^{\infty} \lambda_{\nu_k} (\ln(\nu_{k+1} - \nu_k + 1))^{-\sum_{j=1}^m 1/\theta_j^{(1)}} \tau_k(\bar{x}),$$

where

$$\tau_k(\bar{x}) = \prod_{j=1}^m \sum_{n_j=\nu_k+1}^{\nu_{k+1}} (n_j - \nu_k)^{\frac{1}{p_j}-1} \sin n_j x_j.$$

It is known that (see [22])

$$\|\tau_k\|_{\bar{p}, \bar{\theta}^{(1)}}^* \asymp (\ln(\nu_{k+1} - \nu_k + 1))^{\sum_{j=1}^m 1/\theta_j^{(1)}}, \quad 1 < p_j, \theta_j^{(1)} < +\infty, \quad j = 1, \dots, m. \quad (2.11)$$

Using this relation and (2.9), we can verify that

$$\|f_0\|_{\bar{p}, \bar{\theta}^{(1)}}^* \leq \sum_{k=0}^{\infty} \lambda_{\nu_k} (\ln(\nu_{k+1} - \nu_k + 1))^{-\sum_{j=1}^m 1/\theta_j^{(1)}} \|\tau_k\|_{\bar{p}, \bar{\theta}^{(1)}}^* \leq C \sum_{k=0}^{\infty} \lambda_{\nu_k} < \infty.$$

Hence,  $f_0 \in L_{\bar{p}, \bar{\theta}^{(1)}}^*(\mathbb{I}^m)$ ,  $1 < p_j, \theta_j^{(1)} < \infty$ ,  $j = 1, \dots, m$ .

Let a positive integer  $n$  satisfy the inequalities  $\nu_l \leq n < \nu_{l+1}$ . Then, by the best approximation property and according to relation (2.11) and inequality (2.9), we have

$$\begin{aligned} E_n(f_0)_{\bar{p}, \bar{\theta}^{(1)}} &\leq E_{\nu_l}(f_0)_{\bar{p}, \bar{\theta}^{(1)}} \leq \sum_{k=l}^{\infty} \lambda_{\nu_k} (\ln(\nu_{k+1} - \nu_k + 1))^{-\sum_{j=1}^m 1/\theta_j^{(1)}} \|\tau_k\|_{\bar{p}, \bar{\theta}^{(1)}}^* \ll \\ &\ll \sum_{k=l}^{\infty} \lambda_{\nu_k} \ll \lambda_{\nu_l} \ll 2\lambda_{\nu_{l+1}-1} \leq C_0 \lambda_n. \end{aligned}$$

Hence,  $f_1 = C_0^{-1} f_0 \in E_{\bar{p}, \bar{\theta}^{(1)}}^\lambda$ .

Let us show that  $f_1 \notin L_{\bar{p}, \theta^{(2)}}^*(\mathbb{I}^m)$ ,  $1 < \theta^{(2)} < \infty$ . To this end, we consider the function

$$g_0(\bar{x}) = \sum_{k=0}^{\infty} (\ln(\nu_{k+1} - \nu_k + 1))^{\sum_{j=1}^m \frac{1-\theta^{(2)}}{\theta_j^{(1)}}} \lambda_{\nu_k}^{\theta^{(2)}-1} \xi_k(\bar{x}),$$

where

$$\xi_k(\bar{x}) = \prod_{j=1}^s \sum_{n_j=\nu_k+1}^{\nu_{k+1}} (n_j - \nu_k)^{\frac{1}{p'_j}-1} \sin n_j x_j, \quad p'_j = \frac{p_j}{p_j - 1}, \quad j = 1, \dots, m.$$

It is clear that (see (2.11))

$$\|\xi_k\|_{\bar{p}', \bar{\theta}}^* \asymp (\ln(\nu_{k+1} - \nu_k + 1))^{\sum_{j=1}^m 1/\theta_j}, \quad 1 < p_j < +\infty, \quad 1 < \theta_j < \infty, \quad j = 1, \dots, m.$$

Further, in view of the orthogonality of the trigonometric system, for any number  $N$ , we have

$$\begin{aligned} B_N &\equiv \int_{\mathbb{I}^m} f_1(\bar{x}) \sum_{k=0}^N \lambda_{\nu_k}^{\theta^{(2)}-1} (\ln(\nu_{k+1} - \nu_k + 1))^{\sum_{j=1}^m \frac{1-\theta^{(2)}}{\theta_j^{(1)}}} \xi_k(\bar{x}) d\bar{x} = \\ &= C \sum_{k=0}^N [\ln(\nu_{k+1} - \nu_k + 1)]^{-\theta^{(2)} \sum_{j=1}^m 1/\theta_j^{(1)}} \lambda_{\nu_k}^{\theta^{(2)}} \prod_{j=1}^m \sum_{n_j=\nu_k+1}^{\nu_{k+1}} \frac{1}{n_j - \nu_k} \gg \\ &\gg \sum_{k=0}^N [\ln(\nu_{k+1} - \nu_k + 1)]^{\theta^{(2)} \sum_{j=1}^m (1/\theta_j^{(2)} - 1/\theta_j^{(1)})} \lambda_{\nu_k}^{\theta^{(2)}}. \end{aligned} \quad (2.12)$$

Using the integral Hölder inequality, we obtain

$$B_N \ll \|f_1\|_{\bar{p},\theta^{(2)}}^* \left\| \sum_{k=0}^N (\ln(\nu_{k+1} - \nu_k + 1))^{\sum_{j=1}^m \frac{1-\theta^{(2)}}{\theta_j^{(1)}}} \lambda_{\nu_k}^{\theta^{(2)}-1} \xi_k \right\|_{\bar{p}',\theta^{(2)'}}^*, \quad (2.13)$$

where

$$\theta^{(2)'} = \frac{\theta^{(2)}}{\theta^{(2)} - 1}.$$

We set  $u_k(\bar{x}) = (\ln(\nu_{k+1} - \nu_k + 1))^{\sum_{j=1}^m \frac{1-\theta^{(2)}}{\theta_j^{(1)}}} \lambda_{\nu_k}^{\theta^{(2)}-1} |\xi_k(\bar{x})|$ . Then (see (2.11))

$$\|u_k\|_{\bar{p}',\frac{\bar{\theta}^{(1)}}{\theta^{(2)}-1}}^* \ll \lambda_{\nu_k}^{\theta^{(2)}-1} \equiv \beta_k,$$

$$\|u_k\|_{\bar{p}',\bar{\tau}}^* \ll [\ln(\nu_{k+1} - \nu_k + 1)]^{\sum_{j=1}^m (\frac{1}{\tau_j} - \frac{\theta^{(2)}-1}{\theta_j^{(1)}})} \beta_k, \quad k = 0, 1, \dots$$

Thus, all the conditions of Lemma 1 hold for the sequence of functions  $\{u_k(\bar{x})\}$ . Therefore,

$$\begin{aligned} & \left\| \sum_{k=0}^N (\ln(\nu_{k+1} - \nu_k + 1))^{\sum_{j=1}^m \frac{1-\theta^{(2)}}{\theta_j^{(1)}}} \lambda_{\nu_k}^{\theta^{(2)}-1} \xi_k \right\|_{\bar{p}',\theta^{(2)'}}^* \ll \\ & \ll \left\{ \sum_{k=0}^N (\ln(\nu_{k+1} - \nu_k + 1))^{\theta^{(2)} \sum_{j=1}^m (1/\theta^{(2)} - 1/\theta_j^{(1)})} \lambda_{\nu_k}^{\theta^{(2)}} \right\}^{1-1/\theta^{(2)}}. \end{aligned} \quad (2.14)$$

Now, it follows from inequalities (2.12), (2.13), and (2.14) that

$$\left\{ \sum_{k=0}^N (\ln(\nu_{k+1} - \nu_k + 1))^{\theta^{(2)} \sum_{j=1}^m (1/\theta^{(2)} - 1/\theta_j^{(1)})} \lambda_{\nu_k}^{\theta^{(2)}} \right\}^{1/\theta^{(2)}} \ll \|f_1\|_{\bar{p},\theta^{(2)}}^*.$$

By (2.10), we find that  $f_1 \notin L_{\bar{p},\theta^{(2)}}^*(\mathbb{I}^m)$ ,  $1 < \theta^{(2)} < \theta_j^{(1)} < +\infty$ ,  $j = 1, \dots, m$ . This contradicts the inclusion  $E_{\bar{p},\bar{\theta}^{(1)}}^\lambda \subset L_{\bar{p},\theta^{(2)}}^*(\mathbb{I}^m)$ . The proof of Theorem 3 is complete.  $\square$

*Remark 2.* The results of L.A. Sherstneva [22] follow from Theorems 2 and 3 in the case  $m = 1$ .

### 3. Estimates of best approximations of functions with logarithmic smoothness

Now, let us prove estimates of the value  $E_M(F)_{\bar{p},\bar{\theta}^{(2)}}$  for the classes  $F = \mathbb{B}_{\bar{p},\bar{\theta}^{(1)}}^{(0,\alpha,\tau)}$  and  $F = \mathbb{A}_{\bar{p},\bar{\theta}^{(1)}}^{(0,\gamma,\tau)}$ .

**Theorem 4.** *Let  $1 < p_j < \infty$  and  $1 \leq \theta^{(2)} < \theta_j^{(1)} < \infty$  for  $j = 1, \dots, m$ , and let  $1 \leq \tau \leq \infty$ . If  $\alpha > \sum_{j=1}^m (1/\theta^{(2)} - 1/\theta_j^{(1)})$ , then  $B_{\bar{p},\bar{\theta}^{(1)}}^{(0,\alpha,\tau)} \subset L_{\bar{p},\theta^{(2)}}^*(\mathbb{I}^m)$  and*

$$\|f\|_{\bar{p},\theta^{(2)}}^* \ll \|f\|_{B_{\bar{p},\bar{\theta}^{(1)}}^{(0,\alpha,\tau)}}.$$



P r o o f. Let  $f \in B_{\bar{p}, \bar{\theta}^{(1)}}^{(0, \alpha, \tau)}$ . Then, by the definition of the class, this function can be represented in the form of the series

$$\sum_{\nu=0}^{\infty} Q_{2^{2\nu}}(f, \bar{x}), \quad Q_{2^{2\nu}}(f, \bar{x}) \in \mathfrak{F}_{\square_{2^{2n}}},$$

in the sense of convergence in the quasi-norm of the space  $L_{\bar{p}, \bar{\theta}^{(1)}}^*(\mathbb{I}^m)$  and

$$\left[ \sum_{\nu=0}^{\infty} (2^{\nu\alpha} \|Q_{2^{2\nu}}(f)\|_{\bar{p}, \bar{\theta}}^*)^\tau \right]^{1/\tau} < +\infty.$$

If  $\theta^{(2)} < \tau < \infty$ , then, using the Hölder inequality and taking into account that  $\alpha > \sum_{j=1}^m (1/\theta^{(2)} - 1/\theta_j^{(1)})$ , we obtain

$$\begin{aligned} & \left\{ \sum_{\nu=0}^{\infty} 2^{\nu \sum_{j=1}^m (1/\theta^{(2)} - 1/\theta_j^{(1)})\theta^{(2)}} (\|Q_{2^{2\nu}}(f)\|_{\bar{p}, \bar{\theta}^{(1)}}^*)^{\theta^{(2)}} \right\}^{1/\theta^{(2)}} \leq \\ & \leq \left\{ \sum_{\nu=0}^{\infty} 2^{\nu\tau\alpha} (\|Q_{2^{2\nu}}(f)\|_{\bar{p}, \bar{\theta}^{(1)}}^*)^\tau \right\}^{1/\tau} \left\{ \sum_{\nu=0}^{\infty} 2^{\nu\theta^{(2)}\beta' (\sum_{j=1}^m (1/\theta^{(2)} - 1/\theta_j^{(1)}) - \alpha)} \right\}^{\frac{1}{\theta^{(2)}\beta'}} \leq \\ & \leq C \left\{ \sum_{\nu=0}^{\infty} 2^{\nu\tau\alpha} (\|Q_{2^{2\nu}}(f)\|_{\bar{p}, \bar{\theta}^{(1)}}^*)^\tau \right\}^{1/\tau}, \end{aligned} \quad (3.1)$$

where

$$\beta = \frac{\tau}{\theta^{(2)}}, \quad \beta' = \frac{\beta}{\beta - 1}.$$

If  $\tau = \infty$ , then

$$\begin{aligned} & \left\{ \sum_{\nu=0}^{\infty} 2^{\nu \sum_{j=1}^m (1/\theta^{(2)} - 1/\theta_j^{(1)})\theta^{(2)}} (\|Q_{2^{2\nu}}(f)\|_{\bar{p}, \bar{\theta}^{(1)}}^*)^{\theta^{(2)}} \right\}^{1/\theta^{(2)}} \leq \\ & \leq \sup_{\nu \in \mathbb{N}_0} 2^{\nu\alpha} \|Q_{2^{2\nu}}(f)\|_{\bar{p}, \bar{\theta}^{(1)}}^* \left\{ \sum_{\nu=0}^{\infty} 2^{\nu\theta^{(2)} (\sum_{j=1}^m (1/\theta^{(2)} - 1/\theta_j^{(1)}) - \alpha)} \right\}^{1/\theta^{(2)}}. \end{aligned} \quad (3.2)$$

If  $\tau \leq \theta^{(2)}$ , then, using the Jensen inequality (see [17, p. 125]), we obtain

$$\left\{ \sum_{\nu=0}^{\infty} 2^{\nu \sum_{j=1}^m (1/\theta^{(2)} - 1/\theta_j^{(1)})\theta^{(2)}} (\|Q_{2^{2\nu}}(f)\|_{\bar{p}, \bar{\theta}^{(1)}}^*)^{\theta^{(2)}} \right\}^{1/\theta^{(2)}} \leq \left\{ \sum_{\nu=0}^{\infty} 2^{\nu\tau\alpha} (\|Q_{2^{2\nu}}(f)\|_{\bar{p}, \bar{\theta}^{(1)}}^*)^\tau \right\}^{1/\tau}. \quad (3.3)$$

Thus, (3.1)–(3.3) imply that the series

$$\sum_{\nu=0}^{\infty} 2^{\nu \sum_{j=1}^m (1/\theta^{(2)} - 1/\theta_j^{(1)})\theta^{(2)}} (\|Q_{2^{2\nu}}(f)\|_{\bar{p}, \bar{\theta}^{(1)}}^*)^{\theta^{(2)}} \quad (3.4)$$

is convergent for every function  $f \in B_{\bar{p}, \bar{\theta}^{(1)}}^{(0, \alpha, \tau)}$ .

Taking into account the monotonicity of the best approximation and the properties of the norm, it is easy to verify that

$$\begin{aligned}
\sum_{n=2}^{\infty} \frac{(\ln n)^{\sum_{j=1}^m (1/\theta^{(2)} - 1/\theta_j^{(1)}) - 1}}{n} E_{n, \dots, n}^{\theta^{(2)}}(f)_{\bar{p}, \bar{\theta}^{(1)}} &<< \sum_{\nu=0}^{\infty} 2^{\nu} \sum_{j=1}^m (1/\theta^{(2)} - 1/\theta_j^{(1)})^{\theta^{(2)}} E_{2^{2\nu}, \dots, 2^{2\nu}}^{\theta^{(2)}}(f)_{\bar{p}, \bar{\theta}^{(1)}} << \\
&<< \sum_{\nu=0}^{\infty} 2^{\nu} \sum_{j=1}^m (1/\theta^{(2)} - 1/\theta_j^{(1)})^{\theta^{(2)}} \left( \left\| \sum_{l=\nu}^{\infty} Q_{2^{2l}}(f) \right\|_{\bar{p}, \bar{\theta}^{(1)}}^* \right)^{\theta^{(2)}} << \\
&<< \sum_{\nu=0}^{\infty} 2^{\nu} \sum_{j=1}^m (1/\theta^{(2)} - 1/\theta_j^{(1)})^{\theta^{(2)}} \left( \sum_{l=\nu}^{\infty} \|Q_{2^{2l}}(f)\|_{\bar{p}, \bar{\theta}^{(1)}}^* \right)^{\theta^{(2)}}.
\end{aligned} \tag{3.5}$$

Since  $\theta^{(2)} < \theta_j^{(1)}$ ,  $j = 1, \dots, m$ , we have

$$\sum_{\nu=0}^n 2^{\nu} \sum_{j=1}^m (1/\theta^{(2)} - 1/\theta_j^{(1)})^{\theta^{(2)}} << 2^n \sum_{j=1}^m (1/\theta^{(2)} - 1/\theta_j^{(1)})^{\theta^{(2)}}, \quad n \in \mathbb{N}_0.$$

Therefore, according to [14, Lemma 2.2], we find from (3.5) that

$$\sum_{n=2}^{\infty} \frac{(\ln n)^{\sum_{j=1}^m (1/\theta^{(2)} - 1/\theta_j^{(1)})\theta^{(2)} - 1}}{n} E_{n, \dots, n}^{\theta^{(2)}}(f)_{\bar{p}, \bar{\theta}^{(1)}} << \sum_{\nu=0}^{\infty} 2^{\nu} \sum_{j=1}^m (1/\theta^{(2)} - 1/\theta_j^{(1)})^{\theta^{(2)}} \left( \|Q_{2^{2\nu}}(f)\|_{\bar{p}, \bar{\theta}^{(1)}}^* \right)^{\theta^{(2)}}. \tag{3.6}$$

Since the series (3.4) converges, it follows from (3.6) that

$$\sum_{n=2}^{\infty} \frac{(\ln n)^{\sum_{j=1}^m (1/\theta^{(2)} - 1/\theta_j^{(1)})\theta^{(2)} - 1}}{n} E_{n, \dots, n}^{\theta^{(2)}}(f)_{\bar{p}, \bar{\theta}^{(1)}} < \infty.$$

Hence, by Theorem 3, we have  $f \in L_{\bar{p}, \theta^{(2)}}^*(\mathbb{I}^m)$ .

Let us estimate the quasi-norm  $\|f\|_{\bar{p}, \bar{\theta}^{(1)}}^*$ . By the quasi-norm property and the Hölder inequality, we obtain

$$\begin{aligned}
\|f\|_{\bar{p}, \bar{\theta}^{(1)}}^* &<< \sum_{\nu=0}^{\infty} \|Q_{2^{2\nu}}(f)\|_{\bar{p}, \bar{\theta}^{(1)}}^* << \\
&<< \left( \sum_{\nu=0}^{\infty} 2^{\nu} \sum_{j=1}^m (1/\theta^{(2)} - 1/\theta_j^{(1)})^{\theta^{(2)}} \left( \|Q_{2^{2\nu}}(f)\|_{\bar{p}, \bar{\theta}^{(1)}}^* \right)^{\theta^{(2)}} \right)^{1/\theta^{(2)}}.
\end{aligned} \tag{3.7}$$

Therefore, according to relations (2.2), (3.6), and (3.7), we have

$$\|f\|_{\bar{p}, \bar{\theta}^{(1)}}^* << \left\{ \sum_{\nu=0}^{\infty} 2^{\nu} \sum_{j=1}^m (1/\theta^{(2)} - 1/\theta_j^{(1)})^{\theta^{(2)}} \left( \|Q_{2^{2\nu}}(f)\|_{\bar{p}, \bar{\theta}^{(1)}}^* \right)^{\theta^{(2)}} \right\}^{1/\theta^{(2)}}. \tag{3.8}$$

Taking into account (3.1)–(3.3) and (3.8), we obtain

$$\|f\|_{\bar{p}, \theta^{(2)}}^* << \left\{ \sum_{\nu=0}^{\infty} 2^{\nu\tau(\gamma+1/\tau)} \left( \|Q_{2^{2\nu}}(f)\|_{\bar{p}, \bar{\theta}^{(1)}}^* \right)^{\tau} \right\}^{1/\tau} \tag{3.9}$$

for every function  $f \in B_{\bar{p}, \bar{\theta}^{(1)}}^{(0, \alpha, \tau)}$ . The proof of Theorem 4 is complete.  $\square$

**Theorem 5.** *Let  $1 < p_j < \infty$  and  $1 \leq \theta^{(2)} < \theta_j^{(1)} < \infty$  for  $j = 1, \dots, m$ , and let  $1 \leq \tau \leq \infty$ . If  $\alpha > \sum_{j=1}^m (1/\theta^{(2)} - 1/\theta_j^{(1)})$ , then*

$$E_M(\mathbb{B}_{\bar{p}, \bar{\theta}^{(1)}}^{(0, \alpha, \tau)})_{\bar{p}, \bar{\theta}^{(2)}} \asymp (\log(M+1))^{-\left(\alpha - \sum_{j=1}^m (1/\theta^{(2)} - 1/\theta_j^{(1)})\right)}, \quad M \in \mathbb{N}.$$

*Proof.* Let  $f \in \mathbb{B}_{\bar{p}, \bar{\theta}^{(1)}}^{(0, \alpha, \tau)}$ . We have  $\alpha > \sum_{j=1}^m (1/\theta^{(2)} - 1/\theta_j^{(1)})$ ; therefore,  $f \in L_{\bar{p}, \bar{\theta}^{(2)}}^*(\mathbb{I}^m)$  by Theorem 4. Take a positive integer  $l$  such that  $2^{2^l} \leq M < 2^{2^{l+1}}$ . Then, using the best approximation property and inequality (3.9), we have

$$E_M(f)_{\bar{p}, \bar{\theta}^{(2)}} \leq E_{2^{2^l}}(f)_{\bar{p}, \bar{\theta}^{(2)}} << \left\{ \sum_{\nu=l}^{\infty} 2^{\nu \sum_{j=1}^m (1/\theta^{(2)} - 1/\theta_j^{(1)}) \theta^{(2)}} \left( \|Q_{2^{2^\nu}}(f)\|_{\bar{p}, \bar{\theta}^{(1)}}^* \right)^{\theta^{(2)}} \right\}^{1/\tau}. \quad (3.10)$$

If  $\theta^{(2)} < \tau$ , then by the Hölder inequality and in view of the fact that  $\alpha > \sum_{j=1}^m (1/\theta^{(2)} - 1/\theta_j^{(1)})$ , (3.10) implies that (see formula (3.1))

$$E_M(f)_{\bar{p}, \bar{\theta}^{(2)}} \leq \left\{ \sum_{\nu=0}^{\infty} 2^{\nu \tau \alpha} \left( \|Q_{2^{2^\nu}}(f)\|_{\bar{p}, \bar{\theta}^{(1)}}^* \right)^\tau \right\}^{1/\tau} \times \left\{ \sum_{\nu=l}^{\infty} 2^{\nu \theta^{(2)} \beta' \left( \sum_{j=1}^m (1/\theta^{(2)} - 1/\theta_j^{(1)}) - \alpha \right)} \right\}^{\frac{1}{\theta^{(2)} \beta'}} << 2^{-l(\alpha - \sum_{j=1}^m (1/\theta^{(2)} - 1/\theta_j^{(1)}))} \quad (3.11)$$

for every function  $f \in \mathbb{B}_{\bar{p}, \bar{\theta}^{(1)}}^{(0, \alpha, \tau)}$  in the case  $\theta^{(2)} < \tau$ .

If  $\tau \leq \theta^{(2)}$ , then, arguing as in the proof of formula (3.3), by means of the Jensen inequality, we find from (3.10) that

$$E_M(f)_{\bar{p}, \bar{\theta}^{(2)}} \leq \left\{ \sum_{\nu=0}^{\infty} 2^{\nu \tau \alpha} \left( \|Q_{2^{2^\nu}}(f)\|_{\bar{p}, \bar{\theta}^{(1)}}^* \right)^\tau \right\}^{1/\tau} 2^{-l(\alpha - \sum_{j=1}^m (1/\theta^{(2)} - 1/\theta_j^{(1)}))}. \quad (3.12)$$

Now, taking into account that  $2^{2^l} \leq M < 2^{2^{l+1}}$ , by formulas (3.11) and (3.12), we obtain

$$E_M(f)_{\bar{p}, \bar{\theta}^{(2)}} << (\log(M+1))^{-\left(\alpha - \sum_{j=1}^m (1/\theta^{(2)} - 1/\theta_j^{(1)})\right)}$$

for every function  $f \in \mathbb{B}_{\bar{p}, \bar{\theta}^{(1)}}^{(0, \alpha, \tau)}$ . Thus, the upper estimates are proved.

Let us prove the lower estimates. Consider the function

$$f_2(\bar{x}) = 2^{-(n+1)(\alpha + \sum_{j=1}^m 1/\theta_j^{(1)})} \sum_{s=2^{n+1}+1}^{2^{n+2}} \sum_{\bar{k} \in \square_{2^s} \setminus \square_{2^{s-1}}} \prod_{j=1}^m (k_j - 2^{s-1} + 1)^{\frac{1}{p_j} - 1} e^{i\langle \bar{k}, \bar{x} \rangle},$$

where  $\bar{x} \in \mathbb{I}^m$  and  $n \in \mathbb{N}_0$ . It is well known that

$$\left\| \sum_{s=2^{n+1}}^{2^{n+2}} \sigma_s(f_2) \right\|_{\bar{p}, \bar{\theta}^{(1)}}^* = 2^{-(n+1)(\alpha + \sum_{j=1}^m 1/\theta_j^{(1)})} \left\| \sum_{s=2^{n+1}+1}^{2^{n+2}} \sum_{\bar{k} \in \square_{2^s} \setminus \square_{2^{s-1}}} \prod_{j=1}^m (k_j - 2^{s-1} + 1)^{\frac{1}{p_j} - 1} e^{i\langle \bar{k}, \bar{x} \rangle} \right\|_{\bar{p}, \bar{\theta}^{(1)}}^* <<$$

$$\ll 2^{-(n+1)(\alpha + \sum_{j=1}^m 1/\theta_j^{(1)})} (\log(2^{2^{n+2}} - 2^{2^{n+1}}))_{\sum_{j=1}^m 1/\theta_j^{(1)}} \ll 2^{-(n+1)\alpha}.$$

Thus,

$$\left\{ \sum_{\nu=0}^{\infty} 2^{\nu\tau\alpha} \left( \left\| \sum_{s=2^\nu}^{2^{\nu+1}} \sigma_s(f_2) \right\|_{\bar{p}, \bar{\theta}^{(1)}}^* \right)^\tau \right\}^{1/\tau} = 2^{(n+1)\alpha} \left\| \sum_{s=2^{n+1}}^{2^{n+2}} \sigma_s(f_2) \right\|_{\bar{p}, \bar{\theta}^{(1)}}^* \leq C_1.$$

Hence,  $C_1^{-1} f_2 \in \mathbb{B}_{\bar{p}, \bar{\theta}^{(1)}}^{(0, \alpha, \tau)}$  for  $1 < \theta^{(2)} < \infty$  and  $1 \leq \tau < \infty$ . Next, by the definition of the best approximation and the estimate

$$\left\| \sum_{s=2^{n+1}+1}^{2^{n+2}} \sum_{\bar{k} \in \square_{2^s} \setminus \square_{2^{s-1}}} \prod_{j=1}^m (k_j - 2^{s-1} + 1)^{\frac{1}{p_j} - 1} e^{i\langle \bar{k}, \bar{x} \rangle} \right\|_{\bar{p}, \theta^{(2)}}^* \gg 2^{n \frac{m}{\theta^{(2)}}},$$

we have

$$\begin{aligned} E_{2^{2n}}(f_2)_{\bar{p}, \theta^{(2)}} &= C_1^{-1} \|f_2\|_{\bar{p}, \theta^{(2)}}^* = \\ &= C_1^{-1} 2^{-(n+1)(\alpha + \sum_{j=1}^m 1/\theta_j^{(1)})} \left\| \sum_{s=2^{n+1}+1}^{2^{n+2}} \sum_{\bar{k} \in \square_{2^s} \setminus \square_{2^{s-1}}} \prod_{j=1}^m (k_j - 2^{s-1} + 1)^{\frac{1}{p_j} - 1} e^{i\langle \bar{k}, \bar{x} \rangle} \right\|_{\bar{p}, \theta^{(2)}}^* \gg \\ &\gg 2^{-(n+1)(\alpha - \sum_{j=1}^m (1/\theta^{(2)} - 1/\theta_j^{(1)}))}. \end{aligned}$$

Taking into account that  $2^{2^n} \leq M < 2^{2^{n+1}}$ , we obtain

$$E_M(f_2)_{\bar{p}, \theta^{(2)}} \gg (\log(M+1))^{\left(\alpha - \sum_{j=1}^m (1/\theta^{(2)} - 1/\theta_j^{(1)})\right)}$$

for  $1 \leq \theta^{(2)} < \infty$  and  $1 \leq \tau \leq \infty$ . Thus, the proof of Theorem 5 is complete.  $\square$

**Theorem 6.** *Let  $1 < p_j < \infty$  and  $1 \leq \theta^{(2)} < \theta_j^{(1)} < \infty$  for  $j = 1, \dots, m$ , and let  $1 \leq \tau \leq \infty$ . If  $\gamma > \sum_{j=1}^m (1/\theta^{(2)} - 1/\theta_j^{(1)}) - 1/\tau$ , then*

$$E_M(\mathbb{A}_{\bar{p}, \bar{\theta}^{(1)}}^{(0, \gamma, \tau)})_{\bar{p}, \bar{\theta}^{(2)}} \asymp (\log(M+1))^{-(\gamma + 1/\tau - \sum_{j=1}^m (1/\theta^{(2)} - 1/\theta_j^{(1)}))}.$$

**P r o o f.** Since  $\mathbb{A}_{\bar{p}, \bar{\theta}^{(1)}}^{(0, \gamma, \tau)}$  and  $\mathbb{B}_{\bar{p}, \bar{\theta}^{(1)}}^{(0, \gamma + 1/\tau, \tau)}$  coincide, the statement of Theorem 6 follows from Theorem 5.  $\square$

## 4. Conclusion

The best approximations of functions of the classes  $\mathbb{B}_{\bar{p}, \bar{\theta}^{(1)}}^{(0, \alpha, \tau)}$  and  $\mathbb{A}_{\bar{p}, \bar{\theta}^{(1)}}^{(0, \gamma, \tau)}$  in the space  $L_{\bar{p}, \theta^{(2)}}^*(\mathbb{I}^m)$  have logarithmic order.

Note that estimates of the quantities  $E_M(\mathbb{B}_{\bar{p}, \bar{\theta}^{(1)}}^{(0, \gamma, \tau)})_{\bar{p}, \bar{\theta}^{(2)}}$  and  $E_M(\mathbb{A}_{\bar{p}, \bar{\theta}^{(1)}}^{(0, \gamma, \tau)})_{\bar{p}, \bar{\theta}^{(2)}}$  are unknown in the case  $\theta_j^{(1)} = \theta^{(2)}$ ,  $j = 1, \dots, m$ .

## REFERENCES

1. Akishev G. A. On imbedding of some classes of functions of several variables into the Lorentz space. *Izv. Akad. Nauk Kaz. SSR, Ser. Fiz.-Mat.*, 1982. No. 3. P. 47–51. (in Russian)
2. Akishev G. The estimates of approximations classes in the Lorentz space. *AIP Conf. Proc.*, 2015. Vol. 1676, No. 1. Art. no. 020027. P. 1–4. DOI: [10.1063/1.4930453](https://doi.org/10.1063/1.4930453)
3. Akishev G. An inequality of different metric for multivariate generalized polynomials. *East J. Approx.*, 2006. Vol. 12, No. 1. P. 25–36.
4. Akishev G. A. Estimates for best approximations of functions from the logarithmic smoothness class in the Lorentz space. *Trudy Inst. Mat. Mekh. UrO RAN*, 2017. Vol. 23, No. 3. P. 3–21. DOI: [10.21538/0134-4889-2017-23-3-3-21](https://doi.org/10.21538/0134-4889-2017-23-3-3-21) (in Russian)
5. Andrienko V. A. The imbedding of certain classes of functions. *Math. USSR-Izv.*, 1967. Vol. 1, No. 6. P. 1255–1270.
6. Bekmaganbetov K. A. About order of approximation of Besov classes in metric of anisotropic Lorentz spaces. *Ufimsk. Mat. Zh.*, 2009. Vol. 1, No. 2. P. 9–16. (in Russian)
7. Bekmaganbetov K. A. Order of approximation of Besov classes in the metric of anisotropic Lorentz spaces. In: *Methods of Fourier Analysis and Approximation Theory. Ruzhansky M., Tikhonov S. (eds.)* Appl. Numer. Harmon. Anal. Cham: Birkhäuser, 2016. P. 149–158. DOI: [10.1007/978-3-319-27466-9\\_10](https://doi.org/10.1007/978-3-319-27466-9_10)
8. Blozinski A. P. Multivariate rearrangements and Banach function spaces with mixed norms. *Trans. Amer. Math. Soc.*, 1981. Vol. 263, No. 1. P. 149–167. DOI: [10.2307/1998649](https://doi.org/10.2307/1998649)
9. Cobos F., Domínguez Ó. On Besov spaces of logarithmic smoothness and Lipschitz spaces. *J. Math. Anal. Appl.*, 2015. Vol. 425, No. 1. P. 71–84. DOI: [10.1016/j.jmaa.2014.12.034](https://doi.org/10.1016/j.jmaa.2014.12.034)
10. Cobos F., Domínguez Ó. Approximation spaces, limiting interpolation and Besov spaces. *J. Approx. Theory*, 2015. Vol. 189. P. 43–66. DOI: [10.1016/j.jat.2014.09.002](https://doi.org/10.1016/j.jat.2014.09.002)
11. DeVore R. A., Lorentz G. G. *Constructive Approximation*. Grundlehren Math. Wiss., vol. 33. Berlin, Heidelberg: Springer-Verlag, 1993. 453 p.
12. Dinh Dũng, Temlyakov V. N., Ullrich T. Hyperbolic Cross Approximation. 2016. 154 p. [arXiv:1601.03978v1](https://arxiv.org/abs/1601.03978v1) [math.NA]
13. Domínguez Ó., Tikhonov S. *Function Spaces of Logarithmic Smoothness: Embeddings and Characterizations*. 2018. 162 p. [arXiv:1811.06399v2](https://arxiv.org/abs/1811.06399v2) [math.FA]
14. Johansson H. *Embedding of  $H_p^\omega$  in Some Lorentz Spaces*. Research Reports. Univ. Umeå, 1975. Report No. 6. 26 p.
15. Kolyada V. I. Imbedding theorems and inequalities in various metrics for best approximations. *Mat. Sb. (N.S.)*, 1977. Vol. 102 (144), No. 2. P. 195–215. (in Russian)
16. Kolyada V. I. Rearrangements of functions and embedding theorems. Russian Math. Surveys, 1989. Vol. 44, No. 5 P. 73–117. DOI: [10.1070/RM1989v044n05ABEH002287](https://doi.org/10.1070/RM1989v044n05ABEH002287)
17. Nikol'skii S. M. *Priblizhenie funktsij mnogih peremennykh i teoremy vlozheniya* [Approximation of Function of Several Variables and Imbedding Theorems]. Moscow: Nauka, 1977. 456 p. (in Russian)
18. Nursultanov E. D. Interpolation theorems for anisotropic function spaces and their applications. *Dokl. Akad. Nauk RAN*, 2004. Vol. 394, No. 1. P. 22–25.
19. Nursultanov E. D. Nikol'skii's inequality for different metrics and properties of the sequence of norms of the Fourier sums of a function in the Lorentz space. *Proc. Steklov Inst. Math.*, 2006. Vol. 255. P. 185–202. DOI: [10.1134/S0081543806040158](https://doi.org/10.1134/S0081543806040158)
20. Pietsch A., Approximation spaces. *J. Approx. Theory*, 1981. Vol. 32, No. 2. P. 115–134. DOI: [10.1016/0021-9045\(81\)90109-X](https://doi.org/10.1016/0021-9045(81)90109-X)
21. Romanyuk A. S. Approximation of the isotropic classes  $B_{p,\theta}^r$  of periodic functions of several variables in the space  $L_q$ . *Zb. Pr. Inst. Mat. NAN Ukr.*, 2008. Vol. 5, No. 1. P. 263–278. (in Russian)
22. Sherstneva L. A. On the properties of best Lorentz approximations, and certain embedding theorems. *Soviet Math. (Iz. VUZ)*, 1987. Vol. 31, No. 10. P. 62–73.
23. Smailov E. S., Akishev G. Embedding theorems in the Lorentz space and their applications. *Izv. Akad. Nauk Kaz. SSR, Ser. Fiz.-Mat.*, 1984. No. 1. P. 66–70. (in Russian)
24. Stasyuk S. A. Approximating characteristics of the analogs of Besov classes with logarithmic smoothness. *Ukr. Math. J.*, 2014. Vol. 66, No. 4, P. 553–560. DOI: [10.1007/s11253-014-0952-5](https://doi.org/10.1007/s11253-014-0952-5)

25. Stasyuk S. A. Kolmogorov widths for analogs of the Nikol'skii–Besov classes with logarithmic smoothness. *Ukr. Math. J.*, 2015. Vol. 67, No. 11. P. 1786–1792. DOI: [10.1007/s11253-016-1190-9](https://doi.org/10.1007/s11253-016-1190-9)
26. Storozhenko È. A. Embedding theorems and best approximations. *Math. USSR-Sb.*, 1975. Vol. 26, No. 2. P. 213–224. DOI: [10.1070/SM1975v026n02ABEH002477](https://doi.org/10.1070/SM1975v026n02ABEH002477)
27. Temirgaliev N. Embedding in some Lorentz spaces. *Izv. Vyssh. Uchebn. Zaved. Mat.*, 1980. No. 6. P. 83–85. (in Russian)
28. Temirgaliev N. Embeddings of the classes  $H_p^\omega$  in Lorentz spaces. *Sib. Math. J.*, 1983. Vol. 24, No. 2. P. 287–298. DOI: [10.1007/BF00968743](https://doi.org/10.1007/BF00968743)
29. Temlyakov V. *Multivariate Approximation*. Cambridge University Press. 2018. 551 p. DOI: [10.1017/9781108689687](https://doi.org/10.1017/9781108689687)
30. Ul'janov P. L. The imbedding of certain function classes  $H_p^\omega$ . *Math. USSR-Izv.*, 1968. Vol. 2, No. 3. P. 601–637. DOI: [10.1070/IM1968v002n03ABEH000650](https://doi.org/10.1070/IM1968v002n03ABEH000650)

# GENERAL QUASILINEAR PROBLEMS INVOLVING $p(x)$ -LAPLACIAN WITH ROBIN BOUNDARY CONDITION

Hassan Belaouidel<sup>1</sup>, Anass Ourraoui<sup>2</sup>, Najib Tsouli<sup>3</sup>

Department of Mathematics and Computer Science,  
Faculty of Sciences, University Mohamed I,  
Mohammed V av., P.O. Box 524, Oujda 60000, Morocco

<sup>1</sup>belouidhassan@hotmail.fr, <sup>2</sup>a.ourraoui@gmail.com, <sup>3</sup>tsouli@hotmail.fr

**Abstract:** This paper deals with the existence and multiplicity of solutions for a class of quasilinear problems involving  $p(x)$ -Laplace type equation, namely

$$\begin{cases} -\operatorname{div}(a(|\nabla u|^{p(x)})|\nabla u|^{p(x)-2}\nabla u) = \lambda f(x, u) & \text{in } \Omega, \\ n \cdot a(|\nabla u|^{p(x)})|\nabla u|^{p(x)-2}\nabla u + b(x)|u|^{p(x)-2}u = g(x, u) & \text{on } \partial\Omega. \end{cases}$$

Our technical approach is based on variational methods, especially, the mountain pass theorem and the symmetric mountain pass theorem.

**Keywords:**  $p(x)$ -Laplacian, Mountain pass theorem, Multiple solutions, Critical point theory.

## 1. Introduction

In this paper we study the nonlinear elliptic boundary value problem with Robin conditions

$$\begin{cases} -\operatorname{div}(a(|\nabla u|^{p(x)})|\nabla u|^{p(x)-2}\nabla u) = \lambda f(x, u) & \text{in } \Omega, \\ n \cdot a(|\nabla u|^{p(x)})|\nabla u|^{p(x)-2}\nabla u + b(x)|u|^{p(x)-2}u = g(x, u) & \text{on } \partial\Omega, \end{cases} \quad (1.1)$$

where  $\Omega$  is an open bounded subset of  $\mathbb{R}^N$  ( $N \geq 2$ ), with smooth boundary,  $n$  is the outer unit normal vector on  $\partial\Omega$ ,  $b$  is a positive continuous function defined on  $\mathbb{R}^N$ ,  $p \in C_+(\overline{\Omega})$  with

$$1 < p^- := \inf_{\overline{\Omega}} p(x) \leq p^+ := \sup_{\overline{\Omega}} p(x) < N$$

and  $p(x) < p^*(x)$  where

$$p^*(x) = \begin{cases} \frac{Np(x)}{N-p(x)} & \text{if } p(x) < N, \\ +\infty & \text{if } p(x) \geq N \end{cases}$$

for any  $x \in \overline{\Omega}$ . It is clear that the equation in question is elliptic since it describes phenomena that do not change from moment to moment, and that the operator

$$Lu = -\operatorname{div}(a(|\nabla u|^{p(x)})|\nabla u|^{p(x)-2}\nabla u)$$

is an elliptic operator in divergence form.

Recently, the study of differential equations and variational problems involving  $p(x)$ -growth conditions have been extensively investigated and received much attention because they can be presented as models for many physical phenomena which arouse in the study of elastic mechanics [32], electro-rheological fluid dynamics [27] and image processing [6], electrical resistivity and

polycrystal plasticity [3, 4] and continuum mechanics [2] etc, for an overview of this subject, and for more details we refer readers to [11] and [5, 10] and the references therein. The existence of nontrivial solutions to nonlinear elliptic boundary value problems has been extensively studied by many researchers [1, 7, 14, 15, 18, 21, 23, 24] and references therein.

It is known that the extension  $p(x)$ -Laplace operator possesses more complicated structure than the  $p$ -Laplacian. For example, it is inhomogeneous and usually it does not have the so-called first eigenvalue, since the infimum of its spectrum is zero.

However, to understand the role of the variable exponent, well, although most of the materials can be accurately modeled with the help of the classical Lebesgue and Sobolev spaces  $L^p$  and  $W^{1,p}$ , where  $p$  is a fixed constant, there are some nonhomogeneous materials, for which this is not adequate, e.g. the rheological fluids mentioned above, which are characterized by their ability to drastically change their mechanical properties under the influence of an exterior electromagnetic field. Thus it is necessary for the exponent  $p$  to be nonstandard, therefore, the spaces with variable exponents are required. As an introduction and a history coverage to the subject of variable exponent problems, we advice the reader to see the monograph [12] and the articles [16, 20].

Note that, the  $p(x)$ -Laplace operator in (1.1) is a special case of the divergence form operator  $-\operatorname{div}(a(|\nabla u|^{p(x)})|\nabla u|^{p(x)-2}\nabla u)$  which appears in many nonlinear diffusion problems, in particular in the mathematical modeling of non-Newtonian fluids. When

$$a(t) = 1 + \frac{t}{\sqrt{1+t^2}}$$

we have the generalized Capillary operator (which is essential in applied fields like industrial, biomedical and pharmaceutical) initiated by W. Ni and J. Serrin [22].

Inspired by the works in [25] and [19], we study the existence and multiplicity of nontrivial solutions the problem (1.1), via the mountain pass theorem and the Rabinowitz's symmetric mountain pass theorem [26].

We assume the following conditions:

(A<sub>0</sub>) The function  $a : \mathbb{R}^+ \rightarrow \mathbb{R}$  is continuous and the mapping  $\Theta : \mathbb{R}^N \rightarrow \mathbb{R}$ , given by  $\Theta(\xi) = A(|\xi|^{p(x)})$  is strictly convex, where  $A$  is the primitive of  $a$ , that is

$$A(t) = \int_0^t a(s)ds.$$

(A<sub>1</sub>) There exist two constants  $0 < L < K$  such that  $L \leq a(t) \leq K$  for all  $t \geq 0$ .

We assume that  $f, g : \Omega \times \mathbb{R} \rightarrow \mathbb{R}$  are of Carathéodory functions,  $f(x, \cdot) = g(x, \cdot) = 0$  and satisfy:

(F<sub>0</sub>) for all  $(x, t) \in \Omega \times \mathbb{R}$   $|f(x, t)| \leq f_1(x)|t|^{r(x)-1}$ , such that

$$1 \leq r^- := \inf_{\Omega} r(x) \leq r^+ := \sup_{\Omega} r(x) < p^- := \inf_{\Omega} p(x) \leq p^+ := \sup_{\Omega} p(x),$$

where  $f_1$  is nonnegative, measurable function and  $f_1 \in L^{\frac{p(x)}{p(x)-r(x)}}(\Omega)$ ;

(F<sub>1</sub>) for all  $(x, t) \in \Omega \times \mathbb{R}$   $|f(x, t)| \geq f_2(x)|t|^{\alpha(x)-1}$ ,

$$1 \leq \alpha^- := \inf_{\Omega} \alpha(x) \leq \alpha^+ := \sup_{\Omega} \alpha(x) < r^-,$$

where  $f_2 > 0$  in some nonempty open set  $O \subset \Omega$ ;



( $\mathbf{G}_0$ ) for all  $(x, t) \in \partial\Omega \times \mathbb{R}$ ,  $|g(x, t)| \leq g_1(x)|t|^{q(x)-1}$ ,

$$1 \leq p^+ < q^- := \inf_{\Omega} q(x) \leq q^+ := \sup_{\Omega} q(x), \quad q(x) < p^\partial(x),$$

where

$$p^\partial(x) = (p(x))^\partial = \begin{cases} \frac{(N-1)p(x)}{N-p(x)} & \text{if } p(x) < N, \\ +\infty & \text{if } p(x) \geq N \end{cases}$$

and there exists a positive constants  $C_g$  such that  $0 \leq g_1 \leq C_g$ ;

( $\mathbf{G}_1$ ) for all  $(x, t) \in \partial\Omega \times \mathbb{R}$   $\lim_{t \rightarrow 0} \frac{g(x, t)t}{|t|^{p^+-1}} = 0$ .

( $\mathbf{G}_2$ ) there exists  $\mu > p^+$  such that  $\mu G(x, t) \leq g(x, t)t$  for all  $(x, t) \in \partial\Omega \times \mathbb{R}$ , where

$$G(x, t) = \int_0^t g(x, s) ds.$$

The main result of this paper is as follow.

**Theorem 1.** *Assume that ( $\mathbf{A}_0$ )–( $\mathbf{A}_1$ ), ( $\mathbf{F}_0$ )–( $\mathbf{F}_1$ ) and ( $\mathbf{G}_0$ )–( $\mathbf{G}_2$ ) hold. Then there exists  $\lambda^* > 0$  such that for every  $\lambda \in ]0, \lambda^*[$ , the problem (1.1) admits at least one nontrivial solution. In addition, if we assume the following conditions:*

( $\mathbf{G}_3$ ) *there is a nonempty open set  $U \subset \partial\Omega$  with  $G(x, t) > 0$  for all  $(x, t) \in U \times \mathbb{R}^+$ ,*

( $\mathbf{G}_4$ ) *the functions  $f$  and  $g$  are even,*

*then the problem (1.1) has infinitely many solutions for every  $\lambda > 0$ .*

The remainder of this paper is organized as follows, in Section 2 we introduce some technical results and required hypotheses in order to solve our problem, in Section 3 we state some and prove the main results of this work.

## 2. Preliminaries

In the sequel, let  $p(x) \in C_+(\overline{\Omega})$ , where

$$C_+(\overline{\Omega}) = \{h : h \in C(\overline{\Omega}), h(x) > 1 \text{ for any } x \in \overline{\Omega}\}.$$

The variable exponent Lebesgue space is defined by

$$L^{p(x)}(\Omega) = \left\{ u : \Omega \rightarrow \mathbb{R} \text{ measurable and } \int_{\Omega} |u(x)|^{p(x)} dx < +\infty \right\}$$

furnished with the Luxemburg norm

$$|u|_{L^{p(x)}(\Omega)} = |u|_{p(x)} = \inf \left\{ \sigma > 0 : \int_{\Omega} \left| \frac{u(x)}{\sigma} \right|^{p(x)} dx \leq 1 \right\}.$$

*Remark 1.* Variable exponent Lebesgue spaces resemble to classical Lebesgue spaces in many respects, they are separable Banach spaces and the Hölder inequality holds. The inclusions between Lebesgue spaces are also naturally generalized, that is, if  $0 < \text{mes}(\Omega) < \infty$  and  $p, q$  are

variable exponents such that  $p(x) < q(x)$  a.e. in  $\Omega$ , then there exists a continuous embedding  $L^{q(x)}(\Omega) \hookrightarrow L^{p(x)}(\Omega)$ .

The variable exponent Sobolev space is defined by

$$W^{1,p(x)}(\Omega) = \{u \in L^{p(x)}(\Omega) : |\nabla u| \in L^{p(x)}(\Omega)\}$$

equipped with the norm

$$\|u\|_{W^{1,p(x)}(\Omega)} = |u|_{L^{p(x)}(\Omega)} + |\nabla u|_{L^{p(x)}(\Omega)}.$$

**Proposition 1** [16, 17]. *The spaces  $L^{p(x)}(\Omega)$  and  $W^{1,p(x)}(\Omega)$  are separable, uniformly convex, reflexive Banach spaces. The conjugate space of  $L^{p(x)}(\Omega)$  is  $L^{q(x)}(\Omega)$ , where  $q(x)$  is the conjugate function of  $p(x)$ , i.e.,*

$$\frac{1}{p(x)} + \frac{1}{q(x)} = 1,$$

for all  $x \in \Omega$ . For  $u \in L^{p(x)}(\Omega)$  and  $v \in L^{q(x)}(\Omega)$  we have

$$\left| \int_{\Omega} u(x)v(x)dx \right| \leq \left( \frac{1}{p^-} + \frac{1}{q^-} \right) |u|_{p(x)} |v|_{q(x)}.$$

Moreover, if  $h_1, h_2, h_3 : \bar{\Omega} \rightarrow (1, \infty)$  are Lipschitz continuous functions such that

$$\frac{1}{h_1} + \frac{1}{h_2} + \frac{1}{h_3} = 1,$$

then for any  $u \in L^{h_1(x)}(\Omega)$ ,  $v \in L^{h_2(x)}(\Omega)$ ,  $w \in L^{h_3(x)}(\Omega)$ , the following inequality holds (see [15, Proposition 2.5])

$$\int_{\Omega} |uvw|dx \leq \left( \frac{1}{h_1^-} + \frac{1}{h_2^-} + \frac{1}{h_3^-} \right) |u|_{h_1(x)} |v|_{h_2(x)} |w|_{h_3(x)}.$$

**Proposition 2** [13]. *Let  $p(x)$  and  $q(x)$  be measurable functions such that  $p(x) \in L^{\infty}(\Omega)$  and  $1 \leq p(x)q(x) \leq \infty$ , for a.e.  $x \in \Omega$ . Let  $u \in L^{q(x)}(\Omega)$ ,  $u \neq 0$ . Then*

$$\begin{aligned} |u|_{p(x)q(x)} \leq 1 &\Rightarrow |u|_{p(x)q(x)}^{p^+} \leq \| |u|^{p(x)} \|_{q(x)} \leq |u|_{p(x)q(x)}^{p^-}, \\ |u|_{p(x)q(x)} \geq 1 &\Rightarrow |u|_{p(x)q(x)}^{p^-} \leq \| |u|^{p(x)} \|_{q(x)} \leq |u|_{p(x)q(x)}^{p^+}. \end{aligned}$$

In particular if  $p(x) = p$  is a constant, then

$$\| |u|^p \|_{q(x)} = |u|_{pq(x)}^p.$$

**Proposition 3** [16, 17]. *Assume that the boundary of  $\Omega$  possesses the cone property and  $p, r \in C_+(\bar{\Omega})$  such that  $r(x) \leq p^*(x)$  ( $r(x) < p^*(x)$ ) for all  $x \in \bar{\Omega}$ , then there is a continuous (compact) embedding*

$$W^{1,p(x)}(\Omega) \hookrightarrow L^{r(x)}(\Omega),$$

**Proposition 4** [9]. *For  $p \in C_+(\bar{\Omega})$  and such  $r \in C_+(\partial\Omega)$  that  $r(x) \leq p^{\partial}(x)$  ( $r(x) < p^{\partial}(x)$ ) for all  $x \in \bar{\Omega}$ , there is a continuous (compact) embedding*

$$W^{1,p(x)}(\Omega) \hookrightarrow L^{r(x)}(\partial\Omega).$$

**Proposition 5.** [8, Theorem 2.1] For any  $u \in W^{1,p(x)}(\Omega)$ , let

$$\|u\|_{\partial} := |u|_{L^{p(x)}(\partial\Omega)} + |\nabla u|_{L^{p(x)}(\Omega)}.$$

Then  $\|u\|_{\partial}$  is a norm on  $W^{1,p(x)}(\Omega)$  which is equivalent to

$$\|u\|_{W^{1,p(x)}(\Omega)} = |u|_{L^{p(x)}(\Omega)} + |\nabla u|_{L^{p(x)}(\Omega)}.$$

Now, for any  $u \in X := W^{1,p(x)}(\Omega)$  define

$$\|u\| := \inf \left\{ \sigma > 0 : \int_{\Omega} \left| \frac{\nabla u(x)}{\sigma} \right|^{p(x)} dx + \int_{\partial\Omega} b(x) \left| \frac{u(x)}{\sigma} \right|^{p(x)} d\sigma_x \leq 1 \right\},$$

where  $b \in L^{\infty}(\Omega)$  and  $d\sigma_x$  is the measure on the boundary  $\partial\Omega$ . Then by Proposition 5,  $\|\cdot\|$  is also a norm on  $W^{1,p(x)}(\Omega)$  which is equivalent to  $\|\cdot\|_{W^{1,p(x)}(\Omega)}$  and  $\|\cdot\|_{\partial}$ , the proof of this statement can be found in [8, p. 551]. Now, we introduce the modular  $\rho : X \rightarrow \mathbb{R}$  defined by

$$\rho(u) = \int_{\Omega} |\nabla u|^{p(x)} dx + \int_{\partial\Omega} b(x) |u(x)|^{p(x)} d\sigma_x$$

for all  $u \in X$ . Here, we give some relations between the norm  $\|\cdot\|$  and the modular  $\rho$ .

**Proposition 6** [16]. For  $u \in X$  we have

- (i)  $\|u\| < 1 (= 1; > 1) \Leftrightarrow \rho(u) < 1 (= 1; > 1)$ ;
- (ii) If  $\|u\| < 1 \Rightarrow \|u\|^{p^+} \leq \rho(u) \leq \|u\|^{p^-}$ ;
- (iii) If  $\|u\| > 1 \Rightarrow \|u\|^{p^-} \leq \rho(u) \leq \|u\|^{p^+}$ .

**Proposition 7** [29]. Suppose that  $f : \Omega \times \mathbb{R} \rightarrow \mathbb{R}$  is a Carathéodory function and satisfies the growth condition

$$|f(x, t)| \leq c|t|^{\alpha(x)/\beta(x)} + h(x), \quad \text{for every } x \in \Omega, t \in \mathbb{R},$$

where  $\alpha, \beta \in C_+(\overline{\Omega})$ ,  $c \geq 0$  is constant and  $h \in L^{\beta(x)}(\Omega)$ . Then  $N_f(L^{\alpha(x)}(\Omega)) \subseteq L^{\beta(x)}(\Omega)$ , where  $N_f(u)(x) = f(x, u(x))$ . Moreover,  $N_f$  is continuous from  $L^{\alpha(x)}(\Omega)$  into  $L^{\beta(x)}(\Omega)$  and maps bounded set into bounded set.

As a consequence of Proposition 7, the Carathéodory function  $f$  defines an operator  $N_f$  which is called the Nemytskii operator.

**Definition 1.** We say that  $u \in X$  is weak solution of (1.1) if

$$\int_{\Omega} a(|\nabla u|^{p(x)}) |\nabla u|^{p(x)-2} \nabla u \nabla v dx + \int_{\partial\Omega} b(x) |u|^{p(x)-2} u v d\sigma_x = \lambda \int_{\Omega} f(x, u) v dx + \int_{\partial\Omega} g(x, u) v d\sigma_x$$

for all  $v \in X$ .

Now we introduce the Euler–Lagrange functional  $I_{\lambda} : X \rightarrow \mathbb{R}$  associated with problem (1.1) defined by

$$I_{\lambda}(u) = \int_{\Omega} \frac{1}{p(x)} A(|\nabla u|^{p(x)}) dx + \int_{\partial\Omega} \frac{1}{p(x)} b(x) |u|^{p(x)} d\sigma_x - \lambda \int_{\Omega} F(x, u) dx - \int_{\partial\Omega} G(x, u) d\sigma_x,$$

where

$$F(x, t) := \int_0^t f(x, s) ds.$$

Furthermore, the (weak) solutions of (1.1) are precisely the critical points of the functional  $I_{\lambda}$ .

**Lemma 1** [31] . *Let*

$$L(u) := \int_{\Omega} \frac{1}{p(x)} A(|\nabla u|^{p(x)}) dx + \int_{\partial\Omega} \frac{1}{p(x)} b(x) |u|^{p(x)} d\sigma_x.$$

*Then the mapping  $L : X \rightarrow X^*$  is a strictly monotone, continuous bounded homeomorphism and is of type  $(S_+)$ , namely assumptions  $u_n \rightharpoonup u$  and  $\limsup_{n \rightarrow +\infty} L(u_n)(u_n - u) \leq 0$ , imply  $u_n \rightarrow u$ .*

By Proposition 7, we can see that the functional  $I_\lambda$  is well defined on  $X$  and  $I_\lambda \in C^1(X, \mathbb{R})$  with its Fréchet derivative is giving by

$$\begin{aligned} I'_\lambda(u) \cdot v = & \int_{\Omega} a(|\nabla u|^{p(x)}) |\nabla u|^{p(x)-2} \nabla u \nabla v dx + \int_{\partial\Omega} b(x) |u|^{p(x)-2} u v d\sigma_x \\ & - \lambda \int_{\Omega} f(x, u) v dx - \int_{\partial\Omega} g(x, u) v d\sigma_x \end{aligned}$$

for all  $u, v \in X$ .

Let  $X$  be a real Banach space and let be a functional  $I \in C^1(X, \mathbb{R})$ . We say that  $I$  satisfies the *Palais-Smale condition* on  $X$  ( $(PS)$ -condition, for short) if any sequence  $(u_n) \subset X$  with  $(I(u_n))$  bounded and  $I'(u_n) \rightarrow 0$  as  $n \rightarrow \infty$ , possesses a convergent subsequence. By  $(PS)$ -sequence for  $I$  we understand a sequence  $(u_n) \subset X$  which satisfies the conditions:  $(I(u_n))$  is bounded and  $I'(u_n) \rightarrow 0$  as  $n \rightarrow \infty$ .

The main tools used in proving Theorem 1 are the well known mountain pass theorem and its the symmetric mountain pass theorem.

**Theorem 2** [26, Theorem 2.2]. *Let  $X$  be a real Banach space and let  $I$  belong to  $C^1(X, \mathbb{R})$  satisfying the  $(PS)$ -condition. Suppose that  $I(0) = 0$  and that the following conditions hold:*

(I<sub>1</sub>) *there exist  $\rho > 0$  and  $\varrho > 0$  such that  $I(u) \geq \varrho$  for  $\|u\| = \rho$ ;*

(I<sub>2</sub>) *there exists  $e \in X$  with  $\|e\| > \rho$  such that  $I(e) \leq 0$ .*

*Let*

$$\Gamma = \{ \gamma \in \mathcal{C}([0, 1]; X) : \gamma(0) = 0, \gamma(1) = e \}, \quad c = \inf_{\gamma \in \Gamma} \max_{0 \leq t \leq 1} I(\gamma(t)),$$

*then,  $c$  is a critical value of  $I$ .*

**Theorem 3** [28, Theorem 2.1]. *Let  $X$  be a real Banach space and let  $I$  belong to  $C^1(X, \mathbb{R})$  be even, satisfies  $(PS)$ -condition and  $I(0) = 0$ . If  $X = Y \oplus Z$  with  $\dim Y < \infty$ , and  $I$  satisfies*

(I'₁) *there are constants  $\rho, \delta > 0$  such that  $I|_{\partial B_\rho \cap Z} \geq \delta$*

(I'₂) *there a finite dimensional subspace  $W \subset X$ , with  $\dim Y < \dim W < \infty$  and there is  $M > 0$  such that  $\max_{u \in W} I(u) < M$*

(I'₃) *considering  $M > 0$  given by (I'₂),  $I$  satisfies  $(PS)_c$  for  $0 \leq c \leq M$ .*

*Then  $I$  possesses at least  $\dim W - \dim Y$  pairs of nontrivial critical points.*

### 3. Proof of Theorem 1

To prove Theorem 1 we recall some lemmas presented below.

**Lemma 2.** *Assume that  $(\mathbf{A}_1)$ ,  $(\mathbf{F}_0)$  and  $(\mathbf{G}_2)$  hold. Then the functional  $I_\lambda$  satisfies the Palais-Smale condition on  $X$  ((PS)-condition, for short) at any level  $d$ .*

*P r o o f.* Let  $d \in \mathbb{R}$  and let  $(u_n) \subset X$  be (PS) sequence for  $I_\lambda$ , then

$$I_\lambda(u_n) \rightarrow d \quad \text{and} \quad I'_\lambda(u_n) \rightarrow 0 \quad \text{as} \quad n \rightarrow \infty. \quad (3.1)$$

First, we prove that sequence  $(u_n)$  is bounded in  $X$ . Suppose  $(u_n)$  unbounded, we may assume  $\|u_n\| \rightarrow +\infty$  as  $n \rightarrow \infty$ .

By (2),  $(\mathbf{A}_1)$ ,  $(\mathbf{F}_0)$  and Proposition 6 we have

$$\begin{aligned} I_\lambda(u_n) &= \int_\Omega \frac{1}{p(x)} A(|\nabla u_n|^{p(x)}) dx + \int_{\partial\Omega} \frac{1}{p(x)} b(x) |u_n|^{p(x)} d\sigma_x \\ &\quad - \lambda \int_\Omega F(x, u_n) dx - \int_{\partial\Omega} G(x, u_n) d\sigma_x \\ &\geq \frac{L}{p^+} \int_\Omega |\nabla u_n|^{p(x)} dx + \int_{\partial\Omega} \frac{1}{p^+} b(x) |u_n|^{p(x)} d\sigma_x - \frac{\lambda}{r^+} \int_\Omega f_1(x) |u_n|^{r(x)} dx - \int_{\partial\Omega} G(x, u_n) d\sigma_x \\ &\geq \frac{\min(L, 1)}{p^+} \|u_n\|^{p^-} - \frac{\lambda}{r^+} \int_\Omega f_1(x) |u_n|^{r(x)} dx - \int_{\partial\Omega} G(x, u_n) d\sigma_x. \end{aligned} \quad (3.2)$$

From (3.2),  $(\mathbf{F}_0)$  and Proposition 6 we obtain

$$\begin{aligned} \frac{1}{\mu} I'_\lambda(u_n) \cdot u_n &= \frac{1}{\mu} \int_\Omega a(|\nabla u_n|^{p(x)}) |\nabla u_n|^{p(x)} dx + \frac{1}{\mu} \int_{\partial\Omega} b(x) |u_n|^{p(x)} d\sigma_x \\ &\quad - \frac{\lambda}{\mu} \int_\Omega f(x, u_n) u_n dx - \frac{1}{\mu} \int_{\partial\Omega} g(x, u_n) u_n d\sigma_x \\ &\geq \frac{\min(L, 1)}{\mu} \|u_n\|^{p^-} - \frac{\lambda}{\mu} \int_\Omega f_1(x) |u_n|^{r(x)} dx - \frac{1}{\mu} \int_{\partial\Omega} g(x, u_n) u_n d\sigma_x. \end{aligned} \quad (3.3)$$

Meanwhile, according to  $(\mathbf{F}_0)$ , Proposition 4 and Proposition 2 it yields

$$\begin{aligned} \int_\Omega f_1(x) |u_n|^{r(x)} dx &\leq \int_\Omega |f_1(x)| |u_n|^{r(x)} dx \leq |f_1|_{L^{\frac{p(x)}{p(x)-r(x)}}(\Omega)} \left| |u_n|^{r(x)} \right|_{L^{\frac{p(x)}{r(x)}}(\Omega)} \\ &\leq |f_1|_{L^{\frac{p(x)}{p(x)-r(x)}}(\Omega)} \max \left( |u_n|_{p(x)}^{r^-}, |u_n|_{p(x)}^{r^+} \right) \leq |f_1|_{L^{\frac{p(x)}{p(x)-r(x)}}(\Omega)} \max \left( C_{r^-} \|u_n\|^{r^-}, C_{r^+} \|u_n\|^{r^+} \right), \end{aligned} \quad (3.4)$$

where  $C_{r^-}$  and  $C_{r^+}$  are constants of compact embedding  $X \hookrightarrow L^{p(x)}(\Omega)$ . Using (3.1), (3.2), (3.3), (3.4) and  $(\mathbf{G}_2)$  we obtain

$$\begin{aligned} d + 1 + \|u_n\| &\geq I_\lambda(u_n) - \frac{1}{\mu} I'_\lambda(u_n) \cdot u_n \geq \frac{\min(L, 1)}{p^+} \|u_n\|^{p^-} - \frac{\lambda}{r^+} \int_\Omega f_1(x) |u_n|^{r(x)} dx \\ &\quad - \int_{\partial\Omega} G(x, u_n) d\sigma_x - \frac{\min(L, 1)}{\mu} \|u_n\|^{p^-} - \frac{\lambda}{\mu} \int_\Omega f_1(x) |u_n|^{r(x)} dx - \frac{1}{\mu} \int_{\partial\Omega} g(x, u_n) u_n d\sigma_x \\ &\geq \min(L, 1) \left( \frac{1}{p^+} - \frac{1}{\mu} \right) \|u_n\|^{p^-} - \left( \frac{\lambda}{r^+} + \frac{\lambda}{\mu} \right) \int_\Omega f_1(x) |u_n|^{r(x)} dx + \int_{\partial\Omega} \left( \frac{1}{\mu} g(x, u_n) u_n - G(x, u_n) \right) d\sigma_x \\ &\geq \min(L, 1) \left( \frac{1}{p^+} - \frac{1}{\mu} \right) \|u_n\|^{p^-} - \left( \frac{\lambda}{r^+} + \frac{\lambda}{\mu} \right) |f_1|_{L^{\frac{p(x)}{p(x)-r(x)}}(\Omega)} C_{r^+} \|u_n\|^{r^+}, \end{aligned} \quad (3.5)$$

where  $d$  is defined in (3.1). Since  $p^- \geq r^+$  ( $u_n$ ) is bounded.

Now, with standard arguments, we prove that any  $(PS)_d$  sequence  $(u_n)$  in  $X$  has a convergent subsequence. Indeed, the space  $X$  is a Banach reflexive space then there exists  $u \in X$  such that, up to subsequence still denoted by  $(u_n)$  and by the Sobolev embedding, we obtain:

- $u_n \rightharpoonup u$  in  $X$  as  $n \rightarrow \infty$ ;
- $u_n(x) \rightarrow u(x)$  a.e. in  $\Omega$  as  $n \rightarrow \infty$ ;
- $u_n \rightarrow u$  in  $L^{p(x)}(\Omega)$  as  $n \rightarrow \infty$ ;
- $u_n \rightarrow u$  in  $L^{\frac{p(x)}{p(x)-1}}(\Omega)$  as  $n \rightarrow \infty$ . □

**Proposition 8.** *If  $u_n \rightharpoonup u$  in  $X$  as  $n \rightarrow \infty$ , then*

$$\lim_{n \rightarrow \infty} \int_{\Omega} f_1(x) |u_n|^{r(x)-1} (u_n - u) dx = 0, \tag{3.6}$$

and

$$\lim_{n \rightarrow \infty} \int_{\partial\Omega} g_1(x) |u_n|^{q(x)-1} (u_n - u) d\sigma_x = 0. \tag{3.7}$$

*P r o o f.* To demonstrate (3.6), we use Propositions 1–4 we give

$$\begin{aligned} \int_{\Omega} f_1(x) |u_n|^{r(x)-1} (u_n - u) dx &\leq \int_{\Omega} |f_1(x)| |u_n|^{r(x)-1} |u_n - u| dx \\ &\leq 3C |f_1|_{L^{\frac{p(x)}{p(x)-r(x)}}(\Omega)} \max \left( |u_n|_{p(x)}^{r^- - 1}, |u_n|_{p(x)}^{r^+ - 1} \right) |u_n - u|_{p(x)}, \end{aligned}$$

where  $C$  is positive constant. By the compact embedding  $X \hookrightarrow L^{p(x)}(\Omega)$  and the inequality  $||u_n|_{p(x)} - |u|_{p(x)}| \leq |u_n - u|_{p(x)}$ , we obtain  $|u_n - u|_{p(x)} \rightarrow 0$  in  $L^{p(x)}(\Omega)$  and  $|u_n|_{p(x)} \rightarrow |u|_{p(x)}$ .

Similar arguments establish (3.7).

Now, in virtue of (3.1) and Proposition 8, we have

$$\begin{aligned} &\limsup_{n \rightarrow \infty} \int_{\Omega} a(|\nabla u_n|^{p(x)}) |\nabla u_n|^{p(x)-2} \nabla u_n (\nabla u_n - \nabla u) dx + \int_{\partial\Omega} b(x) |u_n|^{p(x)-2} u_n (u_n - u) d\sigma_x \\ &= \limsup_{n \rightarrow \infty} I'_\lambda(u_n) \cdot u_n + \limsup_{n \rightarrow \infty} \lambda \int_{\Omega} f(x, u_n) (u_n - u) dx + \limsup_{n \rightarrow \infty} \int_{\partial\Omega} g(x, u_n) (u_n - u) d\sigma_x = 0. \end{aligned}$$

Finally, by Lemma 1  $u_n \rightarrow u$  in  $X$ .

To finish the proof of the Theorem 1, we check the geometrical conditions of mountain pass Theorem 2 for  $I_\lambda$ . Indeed

(I<sub>1</sub>) since the embeddings  $X \hookrightarrow L^{i(x)}(\Omega)$  ( $i := p, r, q$ ) and  $X \hookrightarrow L^{i(x)}(\partial\Omega)$  ( $i := p, q$ ) is are compact, there exist positive constants  $C_i$  such that

$$|u|_{i(x)} \leq C_i \|u\|. \tag{3.8}$$

From (G<sub>0</sub>)–(G<sub>1</sub>) it follows, for all  $\varepsilon > 0$ , there exists  $C_\varepsilon > 0$ , such that

$$G(x, u) \leq \frac{\varepsilon}{p^+} |u|^{p^+} + C_\varepsilon |u|^{q(x)}, \quad \text{for all } (x, t) \in \partial\Omega \times \mathbb{R}, \tag{3.9}$$

thus, for  $u \in X$  with  $\|u\| \leq 1$ . By **(A<sub>1</sub>)**, (3.2), (3.4), (3.8) and (3.9), we have

$$\begin{aligned} I_\lambda(u) &\geq \frac{\min(L, 1)}{p^+} \|u\|^{p^+} - \frac{\lambda C_r |f_1|_{L^{p(x)/(p(x)-r(x))}(\Omega)}}{r^-} \|u_n\|^{r^+} - \frac{\varepsilon C_\varepsilon C_p}{p^+} \|u\|^{p^+} - C_q C_g \|u\|^{q^+} \\ &\geq \|u\|^{p^+} \left[ C_1 - \lambda C_2 \|u\|^{r^+ - p^+} - C_3 \|u\|^{q^+ - p^+} \right], \end{aligned} \quad (3.10)$$

where

$$C_1 = \frac{\min(L, 1)}{p^+} - \frac{\varepsilon C_\varepsilon C_p}{p^+}, \quad C_2 = \frac{C_r |f_1|_{L^{p(x)/(p(x)-r(x))}(\Omega)}}{r^-}, \quad C_3 = C_q C_g.$$

If  $\rho = \|u\|$ , we obtain

$$I_\lambda(u) \geq \rho^{p^+} \overbrace{\left[ C_1 - \lambda C_2 \rho^{r^+ - p^+} - C_3 \rho^{q^+ - p^+} \right]}^{\psi(\rho)}. \quad (3.11)$$

A straightforward computation shows that the maximum of the function  $\psi$  is

$$\rho_m = \left( \frac{q^+(p^+ - r^+) \lambda C_2}{r^+(q^+ - r^+) C_3} \right).$$

Inserting this into equation (3.11), we find that the right side is zero for

$$\lambda^* := \frac{C_3}{C_2} \rho_m^{q^+ - r^+} - \frac{C_1}{C_2} \rho_m^{p^+ - r^+}.$$

So, there exist  $\rho > 0$  and  $\varrho > 0$  such that  $I_\lambda(u) \geq \varrho$  for  $\|u\| = \rho$ , from which the demonstration of **(I<sub>1</sub>)** is completed.

Now, put

$$h(\tau) = \tau^{-\mu} G(x, \tau t) - G(x, t) \quad \forall t \geq 1.$$

We have

$$h'(t) = t^{-\mu-1} (g(x, t\tau)t\tau - G(x, t\tau)) \geq 0 \quad \forall t \geq 1$$

by **(G<sub>2</sub>)**. Hence,  $h(\tau) \geq h(1)$  for all  $\tau \geq 1$  that is,

$$G(x, \tau t) \geq \tau^\mu G(x, t) \quad \forall (x, t) \in \partial\Omega \times \mathbb{R}. \quad (3.12)$$

Let  $u \in X$ , for  $t > 1$ , by **(A<sub>0</sub>)** and (3.12), we have

$$\begin{aligned} I_\lambda(tu) &= \int_\Omega \frac{1}{p(x)} A(|\nabla tu|^{p(x)}) dx + \int_{\partial\Omega} \frac{1}{p(x)} b(x) |tu|^{p(x)} d\sigma_x - \lambda \int_\Omega F(x, tu) dx - \int_{\partial\Omega} G(x, tu) d\sigma_x \\ &\leq t^{p^+} \left( \int_\Omega \frac{1}{p(x)} A(|\nabla u|^{p(x)}) dx + \int_{\partial\Omega} \frac{1}{p(x)} b(x) |u|^{p(x)} d\sigma_x \right) \\ &\quad + t^{r^+} \frac{\lambda}{r^+} \int_\Omega f_1(x) |u|^{r(x)} dx - C_4 t^\mu \int_{\partial\Omega} \left[ \frac{\varepsilon}{p^+} |u|^{p^+} + C_\varepsilon |u|^{q(x)} \right] d\sigma_x. \end{aligned}$$

This shows that  $I_\lambda(tu) < 0$ .

Since  $I_\lambda(0) = 0$ , the mountain pass lemma implies the existence of a nontrivial weak solution  $u_1$  with  $I_\lambda(u_1) \geq \varrho$ .

Hence problem (1.1) has at least one nontrivial weak solution in  $X$ .

To complete the proof of the Theorem 1, one must check the conditions of the Theorem 3. So we need some lemmas which we recall below.

*Remark 2.* [30] As the Sobolev space  $X$  is a reflexive and separable Banach space, there exist  $(e_n)_{n \in \mathbb{N}^*} \subseteq X$  and  $(f_n)_{n \in \mathbb{N}^*} \subseteq X^*$  such that  $f_n(e_m) = \delta_{nm}$  for any  $n, m \in \mathbb{N}^*$  and

$$X = \overline{\text{span}\{e_n : n \in \mathbb{N}^*\}}, \quad X^* = \overline{\text{span}\{f_n : n \in \mathbb{N}^*\}}^{w^*}.$$

For  $k \in \mathbb{N}^*$  denote by  $X_k = \text{span}\{e_k\}$ ,  $Y_k = \bigoplus_{j=1}^k X_j$ ,  $Z_k = \bigoplus_k^\infty X_j$ .

**Lemma 3.** *Assume that  $(\mathbf{A}_0)$ – $(\mathbf{A}_1)$ ,  $(\mathbf{F}_0)$ – $(\mathbf{F}_1)$  and  $(\mathbf{G}_0)$ – $(\mathbf{G}_1)$  hold. Then there exists  $\tilde{\lambda} > 0$ ,  $k \in \mathbb{N}$  and  $\rho, \theta > 0$  such that  $I_\lambda / \partial B_\rho \cap X_k \geq \theta$  for all  $0 < \lambda < \tilde{\lambda}$ .*

*P r o o f.* Similarly to (3.10), we have

$$I_\lambda(u) \geq \|u\|^{p^+} [C_1 - \lambda C_2 \|u\|^{r^+ - p^+}] - C_3 \|u\|^{q^+}.$$

Taking  $\rho = \|u\|$ , we get

$$I_\lambda(u) \geq \rho^{p^+} [C_1 - \lambda C_2 \rho^{r^+ - p^+}] - C_3 \rho^{q^+}.$$

Next, we take  $\tilde{\lambda} = C_1 / C_2 \cdot \rho^{p^+ - r^+} > 0$  so that

$$I_\lambda(u) \geq \rho^{p^+} [C_1 - \lambda C_2 \rho^{r^+ - p^+}] - C_3 \rho^{q^+} > 0,$$

which shows that  $I$  verifies the condition  $(\mathbf{I}'_1)$  in Theorem 3.  $\square$

Finally, to show the condition  $(\mathbf{I}'_2)$  in Theorem 3, we use the following lemma.

**Lemma 4.** *Assume that  $(\mathbf{A}_0)$ – $(\mathbf{A}_1)$  and  $(\mathbf{G}_2)$ – $(\mathbf{G}_3)$  hold. Then, given  $m \in \mathbb{N}$ , there exist a subspace  $W$  of  $X$  and a constant  $M_m > 0$ , independent of  $\lambda$ , such that  $\dim W = m$  and  $\max_{u \in W} I_\lambda(u) < M_m$ .*

*P r o o f.* Let  $O$  and  $U$  be defined respectively as in  $(\mathbf{F}_1)$  and in  $(\mathbf{G}_3)$ . We can build the space  $W$ , in the same way as in [28, Lemma 4.3]. So, we consider  $v_1, \dots, v_m$  such that  $v_i \in C_O^\infty(\Omega)$ ,  $\text{supp } v_i \cap \text{supp } v_j = \emptyset$ ,  $\text{supp } v_i \cap O \neq \emptyset$  and  $\text{supp } v_i \cap U \neq \emptyset$ , where  $i = 1, \dots, m, j = 1, \dots, m, i \neq j$ .

By (2), we have

$$\begin{aligned} I_\lambda(u) &= \int_\Omega \frac{1}{p(x)} A(|\nabla u|^{p(x)}) dx + \int_{\partial\Omega} \frac{1}{p(x)} b(x) |u|^{p(x)} d\sigma_x - \lambda \int_\Omega F(x, u) dx - \int_{\partial\Omega} G(x, u) d\sigma_x \\ &\leq \frac{\max(1, K)}{p^-} \max(\|u\|^{p^-}, \|u\|^{p^+}) - \lambda \int_\Omega F(x, u) dx - \int_{\partial\Omega} G(x, u) d\sigma_x, \end{aligned}$$

where  $K$  is defined in  $(\mathbf{A}_0)$ .

For  $u \in W$ , since  $\text{supp } u \cap O \neq \emptyset$  we get

$$I_\lambda(u) \leq \frac{\max(1, K)}{p^-} \max(\|u\|^{p^-}, \|u\|^{p^+}) - \int_{\partial\Omega} G(x, u) d\sigma_x = \tilde{I}(u).$$

Since

$$\max_{u \in W \setminus \{0\}} I_\lambda(u) \leq \max_{u \in W \setminus \{0\}} \tilde{I}(u) = \max_{v \in \partial B_1(0) \cap W \setminus \{0\}} \tilde{I}(v).$$

For  $t > 0$  and  $u \in \partial B_1(0) \cap W \setminus \{0\}$  and  $\varepsilon$  small enough, by  $(\mathbf{F}_1)$ ,  $(\mathbf{G}_2)$ – $(\mathbf{G}_3)$  and (3.9), we obtain

$$\begin{aligned} \tilde{I}(tu) &= \frac{\max(1, K)}{p^-} \max(\|tu\|^{p^-}, \|tu\|^{p^+}) - \int_{\partial\Omega} G(x, tu) d\sigma_x \\ &\leq C_5 \|tu\|^{p^-} - t^\mu \int_{\partial\Omega} \left( \frac{\varepsilon}{p^+} |u|^{p^+} + C_\varepsilon |u|^{q(x)} \right) d\sigma_x \leq C_5 t^{p^-} \|u\|^{p^-} - C_6 t^\mu \|u\|^{q^-}, \end{aligned}$$



where  $C_5 = \max(1, K)/p^-$  and  $C_6$  is the constant of embedding  $X \hookrightarrow L^{q(x)}(\partial\Omega)$ ,

$$\lim_{t \rightarrow +\infty} \tilde{I}(tu) \leq \lim_{t \rightarrow +\infty} \left[ C_5 t^{p^-} - C_6 t^\mu \right]. \quad (3.13)$$

Since  $\mu > p^-$ , by (3.13) we get that there exist a subspace  $W$  of  $X$  and a constant  $M_m > 0$ , independent of  $\lambda$ , such that  $\dim W = m$  and  $\max_{u \in W} I_\lambda(u) < M_m$ . The proof of Lemma 4 is complete.  $\square$

According to Lemma 2, we also have that  $I_\lambda$  satisfies  $(\mathbf{I}_3)$ . Since  $I_\lambda(0) = 0$  and  $I_\lambda$  is even, we may apply Theorem 3 to conclude that  $I_\lambda$  has infinitely many nontrivial solutions.

### Acknowledgements

The authors would like to thank the referees for their valuable comments which improved the presentation of the original manuscript.

### REFERENCES

1. Allaoui M., El Amrouss A., Ourraoui A. Existence of infinitely many solutions for a Steklov problem involving the  $p(x)$ -Laplace operator. *Electron. J. Qual. Theory Differ. Equ.*, 2014. No. 20. P. 1–10. DOI: [10.14232/ejqtde.2014.1.20](https://doi.org/10.14232/ejqtde.2014.1.20)
2. Antontsev S., Shmarev S., Chapter 1. Elliptic equations with anisotropic nonlinearity and nonstandard growth conditions. In: *Handbook of Differential Equations, Stationary Partial Differ. Equ. Chipot M., Quittner P. (eds.)*, 2006. Vol. 3. P. 1–100. DOI: [10.1016/S1874-5733\(06\)80005-7](https://doi.org/10.1016/S1874-5733(06)80005-7)
3. Bocea M., Mihăilescu M.  $\Gamma$ -convergence of power-law functionals with variable exponents. *Nonlinear Anal.: Theory, Methods, Appl.*, 2010. Vol. 73, No. 1. P. 110–121. DOI: [10.1016/j.na.2010.03.004](https://doi.org/10.1016/j.na.2010.03.004)
4. Bocea M., Mihăilescu M., Popovici C. On the asymptotic behavior of variable exponent power-law functionals and applications. *Ric. Mat.*, 2010. Vol. 59. P. 207–238. DOI: [10.1007/s11587-010-0081-x](https://doi.org/10.1007/s11587-010-0081-x)
5. Chabrowski J., Fu Y. Existence of solutions for  $p(x)$ -Laplacian problems on a bounded domain. *J. Math. Anal. Appl.*, 2005. Vol. 306, No. 2. P. 604–618. DOI: [10.1016/j.jmaa.2004.10.028](https://doi.org/10.1016/j.jmaa.2004.10.028)
6. Chen Y., Levine S., Rao M. Variable exponent, linear growth functionals in image restoration. *SIAM J. Appl. Math.*, 2006. Vol. 66, No. 2. P. 1383–1406. DOI: [10.1137/050624522](https://doi.org/10.1137/050624522)
7. Dai G. Infinitely many solutions for a  $p(x)$ -Laplacian equation in  $\mathbb{R}^N$ . *Nonlinear Anal.: Theory, Methods, Appl.*, 2009. Vol. 71, No. 3–4. P. 1133–1139. DOI: [10.1016/j.na.2008.11.037](https://doi.org/10.1016/j.na.2008.11.037)
8. Deng S.-G. Positive solutions for Robin problem involving the  $p(x)$ -Laplacian. *J. Math. Anal. Appl.*, 2009 Vol. 360, No. 2. P. 548–560. DOI: [10.1016/j.jmaa.2009.06.032](https://doi.org/10.1016/j.jmaa.2009.06.032)
9. Deng S.-G. Eigenvalues of the  $p(x)$ -Laplacian Steklov problem. *J. Math. Anal. Appl.*, 2008. Vol. 339, No. 2. P. 925–937. DOI: [10.1016/j.jmaa.2007.07.028](https://doi.org/10.1016/j.jmaa.2007.07.028)
10. Deng S.-G. A local mountain pass theorem and applications to a double perturbed  $p(x)$ -Laplacian equations. *Appl. Math. Comput.*, 2009. Vol. 211, No. 1. P. 234–241. DOI: [10.1016/j.amc.2009.01.042](https://doi.org/10.1016/j.amc.2009.01.042)
11. Diening L., Hästö P., Nekvinda A. Open problems in variable exponent Lebesgue and Sobolev spaces. In: *Function Spaces, Differential Operators And Nonlinear Analysis. Proc. Conference Held in Milovy, Bohemian-Moravian Uplands. Drábek P., Rákosník J. (Eds.) May 28 – June 2, 2004, Milovy, Czech Republic*. Milovy: Math. Inst. Acad. Sci. Czech, 2005. P. 38–58. URL: <https://citeseerx.ist.psu.edu>
12. Diening L., Harjulehto P., Hästö P., Ruzicka M. *Lebesgue and Sobolev Spaces with Variable Exponents*. Lecture Notes in Math., vol. 2017. Berlin, Heidelberg: Springer-Verlag, 2011. 509 p. DOI: [10.1007/978-3-642-18363-8](https://doi.org/10.1007/978-3-642-18363-8)
13. Edmunds D. E., Rákosník J. Sobolev embeddings with variable exponent. *Studia Math.*, 2000. Vol. 143, No. 3. P. 267–293.
14. El Amrouss A., Moradi F., Ourraoui A. Neumann problem in divergence form modeled on the  $p(x)$ -Laplace equation. *Bol. Soc. Parana. Mat. (3)*, 2014. Vol. 32, No. 2. P. 109–117. DOI: [10.5269/bspm.v32i2.20329](https://doi.org/10.5269/bspm.v32i2.20329)
15. Fan X., Han X. Existence and multiplicity of solutions for  $p(x)$ -Laplacian equations in  $\mathbb{R}^N$ . *Nonlinear Anal.: Theory Methods Appl.*, 2004. Vol. 59. P. 173–188. DOI: [10.1016/j.na.2004.07.009](https://doi.org/10.1016/j.na.2004.07.009)

16. Fan X., Zhao D. On the spaces  $L^{p(x)}(\Omega)$  and  $W^{m,p(x)}(\Omega)$ . *J. Math. Anal. Appl.*, 2001. Vol. 263, No. 2. P. 424–446. DOI: [10.1006/jmaa.2000.7617](https://doi.org/10.1006/jmaa.2000.7617)
17. Fan X.-L., Zhang Q.-H. Existence of solutions for  $p(x)$ -Laplacian Dirichlet problem. *Nonlinear Anal.: Theory Methods Appl.*, 2003. Vol. 52, No. 8. P. 1843–1852. DOI: [10.1016/S0362-546X\(02\)00150-5](https://doi.org/10.1016/S0362-546X(02)00150-5)
18. Fu Y., Zhang X. A multiplicity result for  $p(x)$ -Laplacian problem in  $\mathbb{R}^N$ . *Nonlinear Anal.: Theory, Methods, Appl.*, 2009. Vol. 70, No. 6. P. 2261–2269. DOI: [10.1016/j.na.2008.03.038](https://doi.org/10.1016/j.na.2008.03.038)
19. Juárez Hurtado E., Miyagaki O. H., Rodrigues R. S. Existence and Multiplicity of Solutions for a Class of Elliptic Equations Without Ambrosetti–Rabinowitz Type Conditions. *J. Dynam. Differential Equations*, 2018. Vol. 30. P. 405–432. DOI: [10.1007/s10884-016-9542-6](https://doi.org/10.1007/s10884-016-9542-6)
20. Kováčik O., Rákosník J. On spaces  $L^{p(x)}$  and  $W^{k,p(x)}$ . *Czechoslovak Math. J.*, 1991. Vol. 41, No. 4. P. 592–618. URL: <https://dml.cz/handle/10338.dmlcz/102493>
21. Mihăilescu M. On a class of nonlinear problems involving a  $p(x)$ -Laplace type operator. *Czechoslovak Math. J.*, 2008. Vol. 58, No. 1. P. 155–172. URL: <https://dml.cz/handle/10338.dmlcz/128252>
22. Ni W.-M., Serrin J. Existence and non-existence theorems for ground states for quasilinear partial differential equations. *Att. Conveg. Lincei*, 1985. Vol. 7. P. 231–257.
23. Ourraoui A. Multiplicity results for Steklov problem with variable exponent. *Appl. Math. Comput.*, 2016. Vol. 277. P. 34–43. DOI: [10.1016/j.amc.2015.12.043](https://doi.org/10.1016/j.amc.2015.12.043)
24. Ourraoui A. *Some Results for Robin Type Problem Involving  $p(x)$ -Laplacian*. Preprint.
25. Pflüger K. Existence and multiplicity of solutions to a  $p$ -Laplacian equation with nonlinear boundary condition. *Electron. J. Differential Equations*, 1998. Vol. 1998, No. 10. P. 1–13. <http://ejde.math.unt.edu>
26. Rabinowitz P.H. *Minimax Methods in Critical Point Theory with Applications to Differential Equations*. CBMS Regional Conference Series in Mathematics, Vol. 65. Providence, Rhode Island: American Mathematical Society, 1986. 100 p.
27. Růžička M. *Electrorheological Fluids: Modeling and Mathematical Theory*. Lecture Notes in Math., vol. 1748. Berlin, Heidelberg: Springer-Verlag, 2002. 178 p. DOI: [10.1007/BFb0104029](https://doi.org/10.1007/BFb0104029)
28. Silva E. A. B., Xavier M. S. Multiplicity of solutions for quasilinear elliptic problems involving critical Sobolev exponents. *Ann. Inst. H. Poincaré Anal. Non Linéaire*, 2003. Vol. 20, No. 2. P. 341–358. DOI: [10.1016/S0294-1449\(02\)00013-6](https://doi.org/10.1016/S0294-1449(02)00013-6)
29. Zhao D., Fan X. L. On the Nemytskii operators from  $L^{p_1(x)}(\Omega)$  to  $L^{p_2(x)}(\Omega)$ . *J. Lanzhou Univ. Nat. Sci.*, 1998. Vol. 34, No. 1. P. 1–5. (in Chinese)
30. Zhao J. F. *Structure Theory of Banach Spaces*. Wuhan: Wuhan Univ. Press, 1991. (in Chinese)
31. Zhou Q.-M., Ge B. Multiple solutions for a Robin-type differential inclusion problem involving the  $p(x)$ -Laplacian. *Math. Methods Appl. Sci.*, 2013. Vol. 40, No. 18. P. 6229–6238. DOI: [10.1002/mma.2760](https://doi.org/10.1002/mma.2760)
32. Zhikov V. V. Averaging of functionals of the calculus of variations and elasticity theory. *Math. USSR-Izv.*, 1987. Vol. 29, No. 1. P. 33–66. DOI: [10.1070/IM1987v029n01ABEH000958](https://doi.org/10.1070/IM1987v029n01ABEH000958)

# EXISTENCE AND EXPONENTIAL STABILITY OF POSITIVE PERIODIC SOLUTIONS FOR SECOND-ORDER DYNAMIC EQUATIONS

**Faycal Bouchelaghem**

High School of Management Sciences Annaba, Annaba 23000, Algeria  
fyb1500@gmail.com

**Abdelouaheb Ardjouni**

Department of Mathematics and Informatics, Souk Ahras University,  
P.O. Box 1553, Souk Ahras, 41000, Algeria  
abd\_ardjouni@yahoo.fr

**Ahcene Djoudi**

Department of Mathematics, Annaba University,  
P.O. Box 12, Annaba 23000, Algeria  
adjoudi@yahoo.com

**Abstract:** In this article, we establish the existence of positive periodic solutions for second-order dynamic equations on time scales. The main method used here is the Schauder fixed point theorem. The exponential stability of positive periodic solutions is also studied. The results obtained here extend some results in the literature. An example is also given to illustrate this work.

**Keywords:** Positive periodic solutions, Exponential stability, Schauder fixed point theorem, Dynamic equations, Time scales.

## 1. Introduction

Time scales theory was initiated by Stefan Hilger in 1988 as a means of unifying theories from discrete analysis and continuous analysis. Difference equations are defined on discrete sets while differential equations are defined on an interval of the set of real numbers. However, dynamic equations on time scales are very important in the physical applications because they are either difference equations, differential equations or a combination of both. This means that dynamic equations are defined on discrete, connected or combination of both types of sets. Hence, the theory of time scales provides an extension of difference analysis and differential analysis, see [6, 7, 15, 17] and the references therein.

Delay dynamic equations arise in many applications of different fields of science and engineering. For example, these equations appear in applied sciences, physics, chemistry, biology, medicine, etc. In particular, qualitative analysis such as positivity, periodicity and stability of solutions of dynamic equations on time scales has received the attention of many authors, see [1–17] and the references therein.

Let  $\mathbb{T}$  be a periodic time scale such that  $t_0 \in \mathbb{T}$ . In this paper, we are interested in the positivity, periodicity and exponential stability of solutions of second-order dynamic equations. Inspired and

motivated by the references in this paper, we consider the following second-order dynamic equation

$$x^{\Delta\Delta}(t) + a(x^\sigma)^\Delta(t) + q(t)x^\beta(t) - r(t)x^\alpha(t) = 0, \quad t \geq t_0, \quad (1.1)$$

with  $x^\Delta(t_0) + ax^\sigma(t_0) = 0$  and  $x(t_0) = 1$ . Throughout this paper we assume that  $a \geq 0$ ,  $q, r \in C_{rd}([t_0, \infty) \cap \mathbb{T}, \mathbb{R})$ ,  $\alpha, \beta \in (0, \infty)$ . To prove the positivity and periodicity of solutions of (1.1), we convert (1.1) into an equivalent integral equation and then employ the Schauder fixed point theorem. The sufficient conditions for the exponential stability of positive solutions are also considered. In the special case  $\mathbb{T} = \mathbb{R}$ , Dorociakova, Michalkova, Olach and Saga in [13] show the existence and the exponential stability of positive solutions of (1.1). Then, the results presented in this paper extend the main results in [13].

The rest of this work is organized as follows. In Section 2, we present some basic concepts concerning the calculus on time scales that will be used to show our main results. We give some properties of the exponential function on a time scale as well as the Schauder fixed point theorem. We refer the reader to the monograph [18] for more details on the Schauder theorem. In Section 3, we prove our main results for the existence of positive periodic solutions by using the Schauder theorem, and we give an example to illustrate our existence results. In Section 4, we study the exponential stability of a positive periodic solution of (1.1). In Section 5, we establish new sufficient conditions for the existence and the exponential stability for a pipe-tank flow configuration.

## 2. Preliminaries

The theory of dynamic equations is a fairly new branch in mathematics (see [1–10, 14–17]). Dynamic equations extend and unify the difference and differential equations. We assume that most readers are familiar with the basic concepts of the dynamic equations on time scales and for more details we refer to the books [6, 7, 17].

**Definition 1** [6]. *A time scale  $T$  is an arbitrary nonempty closed subset of  $\mathbb{R}$ .*

The definition of periodic time scales was introduced by Kaufmann and Raffoul [16]. The following two definitions are found in [16].

**Definition 2.** *A time scale  $\mathbb{T}$  is said to be periodic provided there exists a  $T > 0$  such that if  $t \in \mathbb{T}$  then  $t \pm T \in \mathbb{T}$ . For  $\mathbb{T} \neq \mathbb{R}$ , the period of the time scale is the smallest positive  $T$ .*

*Example 1* [16]. The following time scales are periodic.

1.  $\mathbb{T} = \bigcup_{i=-\infty}^{\infty} [2(i-1)h, 2ih]$ ,  $h > 0$  has period  $T = 2h$ .
2.  $\mathbb{T} = h\mathbb{Z}$  has period  $T = h$ .
3.  $\mathbb{T} = \mathbb{R}$ .
4.  $\mathbb{T} = \{t = k - q^m : k \in \mathbb{Z}, m \in \mathbb{N}_0\}$  where  $0 < q < 1$  and  $\mathbb{N}_0$  is the natural numbers with zero, has period  $T = 1$ .

*Remark 1* [16]. All periodic time scales are unbounded above and below.

**Definition 3.** *Let  $\mathbb{T} \neq \mathbb{R}$  be a periodic time scale with period  $T$ . The function  $f : \mathbb{T} \rightarrow \mathbb{R}$  is said to be periodic with period  $\omega$  provided there exists a natural number  $n$  such that  $\omega = nT$ ,  $f(t \pm \omega) = f(t)$  for all  $t \in \mathbb{T}$  and  $\omega$  is the smallest number such that  $f(t \pm \omega) = f(t)$ . If  $\mathbb{T} = \mathbb{R}$ ,  $f$  is said to be periodic with period  $\omega > 0$  provided  $\omega$  is the smallest positive number such that  $f(t \pm \omega) = f(t)$  for all  $t \in \mathbb{T}$ .*

**Definition 4** [6]. Let  $\mathbb{T}$  be a time scale. The forward jump operator  $\sigma : \mathbb{T} \rightarrow \mathbb{T}$  is defined by

$$\sigma(t) = \inf \{s \in \mathbb{T} : s > t\} \quad \text{for all } t \in \mathbb{T},$$

while the graininess function  $\mu : \mathbb{T} \rightarrow [0, \infty)$  is defined by

$$\mu(t) = \sigma(t) - t \quad \text{for all } t \in \mathbb{T}.$$

*Remark 2* [16]. Let  $\mathbb{T}$  be a periodic time scale with period  $T$ . Then, the forward jump operator  $\sigma$  satisfies  $\sigma(t \pm nT) = \sigma(t) \pm nT$ . Hence,  $\mu(t \pm nT) = \sigma(t \pm nT) - (t \pm nT) = \sigma(t) - t = \mu(t)$ . So,  $\mu$  is a periodic function with period  $T$ .

**Definition 5** [6]. We say that the function  $f : \mathbb{T} \rightarrow \mathbb{R}$  is regulated if its right-sided limits exist at all right-dense points in  $\mathbb{T}$  and its left-sided limits exist at all left-dense points in  $\mathbb{T}$ .

**Definition 6** [6]. We say that the function  $f : \mathbb{T} \rightarrow \mathbb{R}$  is rd-continuous if it is continuous at every right-dense point  $t \in \mathbb{T}$  and its left-sided limits exist, and is finite at every left-dense point  $t \in \mathbb{T}$ . We denote the set of rd-continuous functions  $f : \mathbb{T} \rightarrow \mathbb{R}$  by

$$C_{rd} = C_{rd}(\mathbb{T}) = C_{rd}(\mathbb{T}, \mathbb{R}).$$

We denote the set of differentiable functions  $f : \mathbb{T} \rightarrow \mathbb{R}$  and whose derivative is rd-continuous by

$$C_{rd}^1 = C_{rd}^1(\mathbb{T}) = C_{rd}^1(\mathbb{T}, \mathbb{R}).$$

**Definition 7** [6]. The delta derivative  $f^\Delta(t)$  of a function  $f : \mathbb{T} \rightarrow \mathbb{R}$  at a point  $t \in \mathbb{T}^k = \mathbb{T} \setminus \{\sup \mathbb{T}\}$  exists provided that for any given  $\varepsilon > 0$ , there exists a neighborhood  $U$  of  $t$  such that

$$|(f(\sigma(t)) - f(s)) - f^\Delta(t)(\sigma(t) - s)| < \varepsilon |\sigma(t) - s| \quad \text{for all } s \in U.$$

We say that the function  $f^\Delta : \mathbb{T}^k \rightarrow \mathbb{R}$  is the delta derivative of  $f$  on  $\mathbb{T}^k$ .

**Definition 8** [6]. A function  $p : \mathbb{T} \rightarrow \mathbb{R}$  is said to be regressive if  $1 + \mu(t)p(t) \neq 0$  for all  $t \in \mathbb{T}$ . We denote the set of all rd-continuous and regressive functions  $p : \mathbb{T} \rightarrow \mathbb{R}$  by  $\mathcal{R} = \mathcal{R}(\mathbb{T}, \mathbb{R})$ . We define the set  $\mathcal{R}^+$  of all rd-continuous and positively regressive functions by

$$\mathcal{R}^+ = \mathcal{R}^+(\mathbb{T}, \mathbb{R}) = \{p \in \mathcal{R} : 1 + \mu(t)p(t) > 0, \forall t \in \mathbb{T}\}.$$

**Theorem 1** [6]. Suppose  $f : \mathbb{T} \rightarrow \mathbb{R}$  is a regulated function. Then there exists a function  $F$  which is pre-differentiable with region of differentiation  $D$  such that

$$F^\Delta(t) = f(t) \quad \text{for all } t \in D.$$

**Definition 9** [6]. Suppose  $f : \mathbb{T} \rightarrow \mathbb{R}$  is a regulated function. We say that the function  $F$  as in Theorem 1 is a pre-antiderivative of  $f$ . The indefinite integral of a regulated function  $f$  is defined by

$$\int f(t) \Delta t = F(t) + C,$$

where  $F$  is a pre-antiderivative of  $f$  and  $C$  is an arbitrary constant. The Cauchy integral is defined by

$$\int_s^t f(t) \Delta t = F(t) - F(s) \quad \text{for all } t, s \in \mathbb{T}.$$

We say that a function  $F : \mathbb{T} \rightarrow \mathbb{R}$  is an antiderivative of  $f : \mathbb{T} \rightarrow \mathbb{R}$  if

$$F^\Delta(t) = f(t) \quad \text{for all } t \in \mathbb{T}^k.$$

**Theorem 2** [6]. *Every rd-continuous function has an antiderivative.*

**Definition 10** [6]. *For  $p \in \mathcal{R}$ , we define the generalized exponential function  $e_p$  as the unique solution of the initial value problem*

$$x^\Delta(t) = p(t)x(t), \quad x(s) = 1, \quad \text{where } s \in \mathbb{T}.$$

We give an explicit formula for  $e_p(t, s)$  by

$$e_p(t, s) = \exp \left( \int_s^t \xi_{\mu(v)}(p(v)) \Delta v \right) \quad \forall s, t \in \mathbb{T},$$

where

$$\xi_\mu(p) = \begin{cases} \frac{\log(1 + \mu p)}{\mu} & \text{if } \mu \neq 0, \\ p & \text{if } \mu = 0, \end{cases}$$

with  $\log$  is the principal logarithm function.

**Lemma 1** [6]. *For  $p, q \in \mathcal{R}$ , we define the functions  $p \oplus q$  and  $\ominus p$  by*

$$(p \oplus q)(t) = p(t) + q(t) + \mu(t)p(t)q(t) \quad \forall t \in \mathbb{T}^k,$$

and

$$\ominus p(t) = -\frac{p(t)}{1 + \mu(t)p(t)} \quad \forall t \in \mathbb{T}^k,$$

which are elements of  $\mathcal{R}$ .

**Lemma 2** [6]. *Let  $p, q \in \mathcal{R}$ . Then*

- (i)  $e_0(t, s) \equiv 1$  and  $e_p(t, t) \equiv 1$ ,
- (ii)  $e_p(\sigma(t), s) = (1 + \mu(t)p(t))e_p(t, s)$ ,
- (iii)  $\frac{1}{e_p(t, s)} = e_{\ominus p}(t, s)$ ,
- (iv)  $e_p(t, s) = \frac{1}{e_p(s, t)} = e_{\ominus p}(s, t)$ ,
- (v)  $e_p(t, s)e_p(s, r) = e_p(t, r)$ ,
- (vi)  $\left( \frac{1}{e_p(\cdot, s)} \right)^\Delta = -\frac{p(t)}{e_p^\sigma(\cdot, s)}$ .

**Lemma 3** [1]. *If  $p \in \mathcal{R}^+$ , then*

$$0 < e_p(t, s) \leq \exp \left( \int_s^t p(v) \Delta v \right) \quad \forall t \in \mathbb{T}.$$

The following Schauder fixed point theorem plays important role to prove the existence results in the next section.

**Theorem 3** [18, Schauder's fixed point theorem]. *Suppose that  $\Omega$  is a bounded closed convex nonempty subset of a Banach space  $X$ . Let  $S : \Omega \rightarrow \Omega$  be a completely continuous mapping. Then  $S$  has a fixed point in  $\Omega$ .*

### 3. Positive periodic solutions

Next theorem guarantee the existence of positive  $\omega$ -periodic solutions of (1.1).

**Theorem 4.** *Assume that there exist positive constants  $m$  and  $M$ , and a rd-continuous function  $k \in C_{rd}([t_0, \infty) \cap \mathbb{T}, \mathbb{R})$  such that*

$$\begin{aligned} a - k &\in \mathcal{R}^+, \\ 0 < m &\leq e_{\ominus(a-k)}(t, t_0) \leq M, \quad t \geq t_0, \end{aligned} \quad (3.1)$$

$$\int_t^{t+\omega} \xi_{\mu(s)} [\ominus(a - k(s))] \Delta s = 0, \quad t \geq t_0, \quad (3.2)$$

and

$$\begin{aligned} k(t)e_{\ominus(a-k)}(\sigma(t), t_0) &= \int_{t_0}^t \left[ r(s) \exp \left( \alpha \int_{t_0}^s \xi_{\mu(v)} [\ominus(a - k(v))] \Delta v \right) \right. \\ &\quad \left. - q(s) \exp \left( \beta \int_{t_0}^s \xi_{\mu(v)} [\ominus(a - k(v))] \Delta v \right) \right] \Delta s, \quad t \geq t_0. \end{aligned} \quad (3.3)$$

Then (1.1) has a positive  $\omega$ -periodic solution.

**P r o o f.** Let  $X = BC_{rd}([t_0, \infty) \cap \mathbb{T}, \mathbb{R})$  be the Banach space of all bounded rd-continuous functions endowed with the supremum norm  $\|x\| = \sup_{t \geq t_0} |x(t)|$ . Consider the bounded closed convex nonempty subset  $\Omega$  of  $X$  as follows

$$\begin{aligned} \Omega &= \left\{ x \in X : x(t + \omega) = x(t), t \geq t_0, m \leq x(t) \leq M, t \geq t_0, \right. \\ &\quad \left. \frac{1}{x^\sigma(t)} \int_{t_0}^t \left[ r(s) x^\alpha(s) - q(s) x^\beta(s) \right] \Delta s = k(t), t \geq t_0 \right\}, \end{aligned}$$

and define the operator  $S : \Omega \rightarrow X$  as follows

$$(Sx)(t) = \exp \left( \int_{t_0}^t \xi_{\mu(s)} \left[ \ominus \left( a - \frac{1}{x^\sigma(s)} \int_{t_0}^s \left[ r(v) x^\alpha(v) - q(v) x^\beta(v) \right] \Delta v \right) \right] \Delta s \right),$$

for  $t \geq t_0$ . We will prove that  $S\Omega \subset \Omega$ . By using (3.1), for every  $x \in \Omega$  and  $t \geq t_0$  we obtain

$$\begin{aligned} (Sx)(t) &= \exp \left( \int_{t_0}^t \xi_{\mu(s)} \left[ \ominus \left( a - \frac{1}{x^\sigma(s)} \int_{t_0}^s \left[ r(v) x^\alpha(v) - q(v) x^\beta(v) \right] \Delta v \right) \right] \Delta s \right) \\ &= e_{\ominus(a-k)}(t, t_0) \leq M. \end{aligned}$$

Also for  $x \in \Omega$  and  $t \geq t_0$  we have

$$\begin{aligned} (Sx)(t) &= \exp \left( \int_{t_0}^t \xi_{\mu(s)} \left[ \ominus \left( a - \frac{1}{x^\sigma(s)} \int_{t_0}^s \left[ r(v) x^\alpha(v) - q(v) x^\beta(v) \right] \Delta v \right) \right] \Delta s \right) \\ &= e_{\ominus(a-k)}(t, t_0) \geq m. \end{aligned}$$

From (3.3), for every  $x \in \Omega$  and  $t \geq t_0$  we obtain

$$\begin{aligned} k(t)(Sx)^\sigma(t) &= k(t) \exp \left( \int_{t_0}^{\sigma(t)} \xi_{\mu(s)} \left[ \ominus \left( a - \frac{1}{x^\sigma(s)} \int_{t_0}^s [r(v)x^\alpha(v) - q(v)x^\beta(v)] \Delta v \right) \right] \Delta s \right) \\ &= k(t) \exp \left( \int_{t_0}^{\sigma(t)} \xi_{\mu(s)} [\ominus(a - k(s))] \Delta s \right) = k(t) e_{\ominus(a-k)}(\sigma(t), t_0) \\ &= \int_{t_0}^t \left[ r(s) \exp \left( \alpha \int_{t_0}^s \xi_{\mu(v)} [\ominus(a - k(v))] \Delta v \right) - q(s) \exp \left( \beta \int_{t_0}^s \xi_{\mu(v)} [\ominus(a - k(v))] \Delta v \right) \right] \Delta s \\ &= \int_{t_0}^t \left[ r(s) (Sx)^\alpha(s) - q(s) (Sx)^\beta(s) \right] \Delta s. \end{aligned}$$

Finally we will prove that for  $x \in \Omega$ ,  $t \geq t_0$  the function  $Sx$  is  $\omega$ -periodic. By using (3.2), for  $x \in \Omega$  and  $t \geq t_0$  we get

$$\begin{aligned} (Sx)(t + \omega) &= \exp \left( \int_{t_0}^{t+\omega} \xi_{\mu(s)} \left[ \ominus \left( a - \frac{1}{x^\sigma(s)} \int_{t_0}^s [r(v)x^\alpha(v) - q(v)x^\beta(v)] \Delta v \right) \right] \Delta s \right) \\ &= \exp \left( \int_{t_0}^t \xi_{\mu(s)} \left[ \ominus \left( a - \frac{1}{x^\sigma(s)} \int_{t_0}^s [r(v)x^\alpha(v) - q(v)x^\beta(v)] \Delta v \right) \right] \Delta s \right) \\ &\quad \times \exp \left( \int_t^{t+\omega} \xi_{\mu(s)} \left[ \ominus \left( a - \frac{1}{x^\sigma(s)} \int_{t_0}^s [r(v)x^\alpha(v) - q(v)x^\beta(v)] \Delta v \right) \right] \Delta s \right) \\ &= (Sx)(t) \exp \left( \int_t^{t+\omega} \xi_{\mu(s)} [\ominus(a - k(s))] \Delta s \right) = (Sx)(t). \end{aligned}$$

So  $Sx$  is  $\omega$ -periodic on  $[t_0, \infty) \cap \mathbb{T}$ . Hence,  $S\Omega \subset \Omega$ .

Now, we need to prove that the mapping  $S$  is completely continuous. So we will show that the mapping  $S$  is continuous. Let  $x_i \in \Omega$  be such that  $x_i \rightarrow x \in \Omega$  as  $i \rightarrow \infty$ . For  $t \geq t_0$ , we have

$$\begin{aligned} |(Sx_i)(t) - (Sx)(t)| &= \left| \exp \left( \int_{t_0}^t \xi_{\mu(s)} \left[ \ominus \left( a - \frac{1}{x_i^\sigma(s)} \int_{t_0}^s [r(v)x_i^\alpha(v) - q(v)x_i^\beta(v)] \Delta v \right) \right] \Delta s \right) \right. \\ &\quad \left. - \exp \left( \int_{t_0}^t \xi_{\mu(s)} \left[ \ominus \left( a - \frac{1}{x^\sigma(s)} \int_{t_0}^s [r(v)x^\alpha(v) - q(v)x^\beta(v)] \Delta v \right) \right] \Delta s \right) \right|. \end{aligned}$$

By applying the Lebesgue dominated convergence theorem we obtain that

$$\lim_{i \rightarrow \infty} \|Sx_i - Sx\| = 0.$$

Therefore  $S$  is continuous.

Next, we are going to prove that  $S\Omega$  is relatively compact by applying the Arzela–Ascoli theorem. The uniform boundedness of  $S\Omega$  follows from the definition of  $\Omega$ . For  $t \geq t_0$  and  $x \in \Omega$  we have

$$\begin{aligned} |(Sx)^\Delta(t)| &= \left| - \left( a - \frac{1}{x^\sigma(t)} \int_{t_0}^t [r(v)x^\alpha(v) - q(v)x^\beta(v)] \Delta v \right) \right| \\ &\quad \times \exp \left( \int_{t_0}^{\sigma(t)} \xi_{\mu(s)} \left[ \ominus \left( a - \frac{1}{x^\sigma(s)} \int_{t_0}^s [r(v)x^\alpha(v) - q(v)x^\beta(v)] \Delta v \right) \right] \Delta s \right) \\ &= \left| \ominus \left( a - \frac{1}{x^\sigma(t)} \int_{t_0}^t [r(v)x^\alpha(v) - q(v)x^\beta(v)] \Delta v \right) \right| \\ &\quad \times \exp \left( \int_{t_0}^t \xi_{\mu(s)} \left[ \ominus \left( a - \frac{1}{x^\sigma(s)} \int_{t_0}^s [r(v)x^\alpha(v) - q(v)x^\beta(v)] \Delta v \right) \right] \Delta s \right) \\ &= |\ominus(a - k(t))| e_{\ominus(a-k)}(t, t_0) \leq M_1, \quad M_1 > 0, \end{aligned}$$



which implies that the family  $S\Omega$  is equicontinuous. By using the Arzela–Ascoli theorem  $S\Omega$  is relatively compact. Therefore,  $S$  is completely continuous. By Theorem 3 there is an  $x_0 \in \Omega$  such that  $Sx_0 = x_0$ . We see that  $x_0$  is a positive  $\omega$ -periodic solution of (1.1). The proof is complete.  $\square$

To illustrate the applications of Theorem 4 we give the following example.

*Example 2.* Consider the dynamic equation on  $\mathbb{T} = \pi\mathbb{Z}$  then  $\mu(t) = \pi$ ,

$$x^{\Delta\Delta}(t) + a(x^\sigma)^\Delta(t) + q(t)x^\beta(t) - r(t)x^\alpha(t) = 0, \quad t \geq t_0. \quad (3.4)$$

We take  $t_0 \in \mathbb{T}$  which

$$a = \frac{e^{\cos t_0} - 1}{\pi} \geq 0, \quad k(t) = a - \frac{e^{\cos t} - 1}{\pi}, \quad \omega = 4\pi, \quad \alpha, \beta \in (0, \infty).$$

Then for the conditions (3.1), (3.2) and  $\omega = 4\pi$  we obtain

$$1 + \mu(t)(a - k(t)) = e^{\cos t} > 0, \quad t \geq t_0, \quad \text{then } a - k \in \mathcal{R}^+,$$

$$\begin{aligned} & \int_t^{t+\omega} \xi_{\mu(s)}[\ominus(a - k(s))] \Delta s = \int_t^{t+4\pi} \frac{1}{\mu(s)} \log[1 + \mu(s)(\ominus(a - k(s)))] \Delta s \\ &= \int_t^{t+4\pi} \frac{1}{\pi} \log\left[\frac{-(a - k(s))}{1 + \mu(s)(a - k(s))} \mu(s) + 1\right] \Delta s = - \int_t^{t+4\pi} \frac{1}{\pi} \log[1 + \mu(t)(a - k(s))] \Delta s \\ &= - \int_t^{t+4\pi} \frac{1}{\pi} \cos(s) \Delta s = \frac{1}{2} \cos(s) \Big|_t^{t+4\pi} = 0, \quad t \geq t_0, \end{aligned}$$

and

$$\begin{aligned} e_{\ominus(a-k)}(t, t_0) &= \exp \int_{t_0}^t \xi_{\mu(s)}[\ominus(a - k(s))] \Delta \\ &= \exp \int_{t_0}^t \frac{1}{\mu(s)} \log[1 + \mu(s)(\ominus(a - k(s)))] \Delta s = e^{(\cos t - \cos t_0)/2}, \quad t \geq t_0. \end{aligned}$$

We take  $m = e^{-1}$  and  $M = e$ , then

$$0 < m \leq e_{\ominus(a-k)}(t, t_0) \leq M, \quad t \geq t_0.$$

Also, we put

$$r(t) = \frac{e^{\frac{1}{2}\cos t} - e^{-\frac{1}{2}\cos t}}{\pi} e^{-\frac{\alpha}{2}(\cos t - \cos t_0)} \left(a + \frac{1}{\pi}\right) e^{-\frac{1}{2}\cos t_0},$$

and

$$q(t) = \frac{e^{-\frac{1}{2}\cos t} - e^{\frac{1}{2}\cos t}}{\pi^2} e^{-\frac{\beta}{2}(\cos t - \cos t_0)} e^{-\frac{1}{2}\cos t_0},$$

then

$$\begin{aligned} k(t)e_{\ominus(a-k)}(\sigma(t), t_0) &= \left(a - \frac{e^{\cos t} - 1}{\pi}\right) \exp \int_{t_0}^{\sigma(t)} \xi_{\mu(s)}[\ominus(a - k(s))] \Delta s \\ &= \left(a + \frac{1}{\pi}\right) e^{-\frac{1}{2}(\cos(t) + \cos t_0)} - \frac{1}{\pi} e^{\frac{1}{2}(\cos(t) - \cos t_0)}, \quad t \geq t_0, \end{aligned}$$

and

$$\begin{aligned} & \int_{t_0}^t r(s) \exp\left(\alpha \int_{t_0}^s \xi_{\mu(v)} [\ominus(a - k(v))] \Delta v\right) - q(s) \exp\left(\beta \int_{t_0}^s \xi_{\mu(v)} [\ominus(a - k(v))] \Delta v\right) \Delta s \\ &= \int_{t_0}^t \left[ \frac{e^{\frac{1}{2} \cos s} - e^{-\frac{1}{2} \cos s}}{\pi} \left(a + \frac{1}{\pi}\right) e^{-\frac{1}{2} \cos t_0} - \frac{e^{-\frac{1}{2} \cos s} - e^{\frac{1}{2} \cos s}}{\pi^2} e^{-\frac{1}{2} \cos t_0} \right] \Delta s \\ &= \left(a + \frac{1}{\pi}\right) e^{-\frac{1}{2}(\cos t + \cos t_0)} - \frac{1}{\pi} e^{\frac{1}{2}(\cos t - \cos t_0)}, \quad t \geq t_0. \end{aligned}$$

All conditions of Theorem 4 are satisfied. Thus (3.4) has a positive  $\omega = 4\pi$ -periodic solution

$$x(t) = e_{\ominus(a-k)}(t, t_0) = e^{\frac{1}{2}(\cos t - \cos t_0)}, \quad t \geq t_0,$$

with  $x(t_0) = 1$  and

$$x^\Delta(t_0) + ax^\sigma(t_0) = e^{-\frac{1}{2} \cos t_0} \left( \frac{e^{-\frac{1}{2} \cos t_0} - e^{\frac{1}{2} \cos t_0}}{\pi} \right) + ae^{-\cos t_0} = 0.$$

#### 4. Exponential stability of positive periodic solutions

In this section, we will prove the exponential stability of a positive  $\omega$ -periodic solution of (1.1). Let  $x_1$  be the positive  $\omega$ -periodic solution of (1.1) with the initial condition  $x_1(t_0) = 1$  and  $x_1^\Delta(t_0) + ax_1^\sigma(t_0) = 0$ . Let  $x$  be the another positive  $\omega$ -periodic solution of (1.1) with the initial condition  $x(t_0) = c_1 > 0$ ,  $c_1 \neq 1$  and  $x^\Delta(t_0) + ax^\sigma(t_0) = 0$ . Let

$$y(t) = x(t) - x_1(t), \quad t \geq t_0.$$

After integration of (1.1), we obtain

$$\int_{t_0}^t x^{\Delta\Delta}(s) \Delta s + a \int_{t_0}^t (x^\sigma)^\Delta(s) \Delta s + \int_{t_0}^t [q(s)x^\beta(s) - r(s)x^\alpha(s)] \Delta s = 0,$$

so

$$x^\Delta(t) - x^\Delta(t_0) + ax^\sigma(t) - ax^\sigma(t_0) = \int_{t_0}^t [r(s)x^\alpha(s) - q(s)x^\beta(s)] \Delta s.$$

Then

$$x^\Delta(t) + ax^\sigma(t) = \int_{t_0}^t [r(s)x^\alpha(s) - q(s)x^\beta(s)] \Delta s.$$

In a similar way one can easily show that

$$x_1^\Delta(t) + ax_1^\sigma(t) = \int_{t_0}^t [r(s)x_1^\alpha(s) - q(s)x_1^\beta(s)] \Delta s.$$

Therefore

$$\begin{aligned} y^\Delta(t) &= x^\Delta(t) - x_1^\Delta(t) = -a[x^\sigma(t) - x_1^\sigma(t)] \\ &+ \int_{t_0}^t [r(s)(x^\alpha(s) - x_1^\alpha(s)) - q(s)(x^\beta(s) - x_1^\beta(s))] \Delta s. \end{aligned}$$

This implies

$$y^\Delta(t) = -ay^\sigma(t) + \int_{t_0}^t [r(s)(x^\alpha(s) - x_1^\alpha(s)) - q(s)(x^\beta(s) - x_1^\beta(s))] \Delta s.$$

By using the mean value theorem, we get

$$\begin{aligned} y^\Delta(t) &= -ay^\sigma(t) + \int_{t_0}^t \left[ r(s)\alpha x_*^{\alpha-1}(s)(x(s) - x_1(s)) - q(s)\beta x_0^{\beta-1}(s)(x(s) - x_1(s)) \right] \Delta s \\ &= -ay^\sigma(t) + \int_{t_0}^t \left[ r(s)\alpha x_*^{\alpha-1}(s) - q(s)\beta x_0^{\beta-1}(s) \right] y(s) \Delta s, \quad t \geq t_0, \end{aligned} \quad (4.1)$$

for  $x_*, x_0 \in [x, x_1]$  or  $x_*, x_0 \in [x_1, x]$ .

For  $m \leq x(t) \leq M$ , we suppose that the function

$$f(t, x(t)) = -ax^\sigma(t) + \int_{t_0}^t \left[ r(s)x^\alpha(s) - q(s)x^\beta(s) \right] \Delta s, \quad t \geq t_0,$$

is Lipschitzian in second argument.

**Definition 11.** Assume that  $x_1$  is the positive  $\omega$ -periodic solution of (1.1). If there exist positive constants  $K_{x_1}$  and  $\lambda$  for every positive  $\omega$ -periodic solution  $x$  of (1.1) such that

$$0 < m_* \leq x(t) \leq M_*, \quad m_* \leq m, \quad M_* \geq M, \quad x^\Delta(t_0) + ax^\sigma(t_0) - x_1^\Delta(t_0) - ax_1^\sigma(t_0) = 0$$

and

$$|x(t) - x_1(t)| < K_{x_1} e_{\ominus\lambda}(t, 0) \quad \forall t > t_0,$$

then  $x_1$  is said to be exponentially stable.

In the next theorem, we prove the exponential stability of the positive periodic solution  $x_1$  of (1.1).

**Theorem 5.** Assume that  $q, r \in C_{rd}([t_0, \infty) \cap \mathbb{T}, (t_0, \infty))$  and there exist positive constants  $m$  and  $M$ , and a function  $k \in C_{rd}([t_0, \infty) \cap \mathbb{T}, \mathbb{R})$  such that (3.1)–(3.3) hold. Let  $a > 0$ ,  $0 < \alpha < \beta < 1$  and there exist constants  $m_*, M_* \in (0, \infty)$  such that  $m_* \leq m$ ,  $M_* \geq M$  and

$$\alpha m_*^{\alpha-1} r(t) - \beta M_*^{\beta-1} q(t) \leq 0 \quad \text{for } t \geq t_0.$$

Then (1.1) has a positive  $\omega$ -periodic solution which is exponentially stable.

*P r o o f.* Conditions (3.1)–(3.3) imply that (1.1) has a positive  $\omega$ -periodic solution  $x_1$ . Let  $x$  be a positive  $\omega$ -periodic solution of (1.1) such that  $m_* \leq x(t) \leq M_*$ ,

$$x^\Delta(t_0) + ax^\sigma(t_0) - x_1^\Delta(t_0) - ax_1^\sigma(t_0) = 0.$$

We prove that there exists  $\lambda \in (0, \infty)$  such that

$$|x(t) - x_1(t)| < K_{x_1} e_{\ominus\lambda}(t, 0), \quad t \geq t_0,$$

where  $K_{x_1} = e_\lambda(t_0, 0) |y(t_0)| + 1$ .

We define the Lyapunov function

$$L(t) = |y(t)| e_\lambda(t, 0), \quad t \geq t_0, \quad \lambda \in (0, a).$$

For  $t > t_0$ , we assume that  $L(t) < K_{x_1}$ . On the other hand there exists  $t_* \geq t_0$  such that  $L(t_*) = K_{x_1}$  and  $L(t) < K_{x_1}$  for  $t \in [t_0, t_*)$ . By calculation of the upper left delta derivative of  $L(t)$  along the solution of (4.1), we get

$$\begin{aligned} (L(t))^{\Delta^-} &\leq -a |y^\sigma(t)| e_\lambda(t, 0) + e_\lambda(t, 0) \int_{t_0}^t \left[ r(s)\alpha x_*^{\alpha-1}(s) - q(s)\beta x_0^{\beta-1}(s) \right] |y(s)| \Delta s \\ &\quad + \lambda |y^\sigma(t)| e_\lambda(t, 0), \quad t \geq t_0. \end{aligned}$$

For  $t = t_*$  we have

$$\begin{aligned} 0 \leq (L(t_*))^{\Delta^-} &\leq (\lambda - a) |y^\sigma(t_*)| e_\lambda(t_*, 0) + e_\lambda(t_*, 0) \int_{t_0}^{t_*} [r(s) \alpha x_*^{\alpha-1}(s) - q(s) \beta x_0^{\beta-1}(s)] |y(s)| \Delta s \\ &\leq (\lambda - a) |y^\sigma(t_*)| e_\lambda(t_*, 0) + e_\lambda(t_*, 0) \int_{t_0}^{t_*} [\alpha m_*^{\alpha-1} r(s) - \beta M_*^{\beta-1} q(s)] |y(s)| \Delta s \\ &\leq (\lambda - a) |y^\sigma(t_*)| e_\lambda(t_*, 0). \end{aligned}$$

If  $y(t) > 0$ ,  $t \geq t_0$ , then from (4.1) it follows that, for  $t \geq t_0$ , the function  $y$  is decreasing. If  $y(t) < 0$ ,  $t \geq t_0$ , then  $y$  is increasing for  $t \geq t_0$ . We conclude that  $|y(t)|$ ,  $t \geq t_0$  has decreasing character. Then we obtain

$$0 \leq (L(t_*))^{\Delta^-} \leq (\lambda - a) |y(t_*)| e_\lambda(t_*, 0) \leq (\lambda - a) K_{x_1} < 0,$$

which is a contradiction. Hence, we get

$$|y(t)| e_\lambda(t, 0) < K_{x_1} \quad \text{for } t \geq t_0 \quad \text{and some } \lambda \in (0, a).$$

The proof is complete.  $\square$

## 5. Application in a pipe-tank configuration

In [11], Cid et al. reformulated the problem of fluid motion in the pipe into the following periodic boundary value problem

$$\begin{cases} u''(t) + au'(t) = \frac{1}{u(t)}(e(t) - b(u'(t))^2) - c, & t \in [0, \omega], \\ u(0) = u(\omega), \quad u'(0) = u'(\omega), \end{cases} \quad (5.1)$$

where  $a \geq 0$ ,  $b > 1$ ,  $c > 0$  and  $e$  is  $\omega$ -periodic continuous on  $\mathbb{R}$ . By using the change of variables  $u = x^{1/(b+1)}$ , the singular problem (5.1) can be transformed to the following regular problem

$$\begin{cases} x''(t) + ax'(t) + q(t)x^\beta(t) - r(t)x^\alpha(t) = 0, & t \in [0, \omega], \\ x(0) = x(\omega), \quad x'(0) = x'(\omega), \end{cases}$$

where

$$r(t) = (b+1)e(t), \quad q(t) = (b+1)c, \quad \alpha = \frac{b-1}{b+1}, \quad \beta = \frac{b}{b+1},$$

with  $0 < \alpha < \beta < 1$ .

We will give new sufficient conditions ensuring the existence and the exponential stability of positive  $\omega$ -periodic solutions of the following dynamic equation

$$x^{\Delta\Delta}(t) + a(x^\sigma)^\Delta(t) + (b+1)[cx^\beta(t) - e(t)x^\alpha(t)] = 0, \quad t \geq t_0. \quad (5.2)$$

With respect to Theorems 4 and 5, we obtain the following theorem.

**Theorem 6.** *Assume that  $a > 0$ ,  $0 < \alpha < \beta < 1$  and there exist positive constants  $m$  and  $M$ , and a function  $k \in C_{rd}([t_0, \infty) \cap \mathbb{T}, \mathbb{R})$  such that (3.1) and (3.2) hold and*

$$\begin{aligned} k(t)e_{\ominus(a-k)}(\sigma(t), t_0) &= (b+1) \int_{t_0}^t e(s) \exp\left(\alpha \int_{t_0}^s \xi_{\mu(v)}[\ominus(a-k(v))] \Delta v\right) \\ &\quad - c \exp\left(\beta \int_{t_0}^s \xi_{\mu(v)}[\ominus(a-k(v))] \Delta v\right) \Delta s, \quad t \geq t_0. \end{aligned} \quad (5.3)$$

Then (5.2) has a positive  $\omega$ -periodic solution.

**Theorem 7.** Assume that  $e \in C_{rd}([t_0, \infty) \cap \mathbb{T}, (t_0, \infty))$ ,  $a > 0$ ,  $0 < \alpha < \beta < 1$ ,  $c > 0$  and there exist positive constants  $m$  and  $M$ , and a function  $k \in C_{rd}([t_0, \infty) \cap \mathbb{T}, \mathbb{R})$  such that (3.1), (3.2) and (5.3) hold. Let, in addition, there exist constants  $m_*, M_* \in (0, \infty)$  such that  $m_* \leq m$ ,  $M_* \geq M$  and

$$\alpha m_*^{\alpha-1} e(t) - \beta M_*^{\beta-1} c \leq 0 \quad \text{for } t \geq t_0.$$

Then (5.2) has a positive  $\omega$ -periodic solution which is exponentially stable.

## 6. Conclusion

In this paper, we provided the existence and exponential stability of positive periodic solutions with sufficient conditions for second-order dynamic equations on time scales. The main tools of this paper are the fixed point method and the Lyapunov method. However, by introducing new fixed mappings and suitable Lyapunov functionals, we get new existence and exponential stability conditions. An example illustrating our results is presented. The obtained results have a contribution to the related literature, and they improve and extend the results in [13] from the case of second-order differential equations to that case with second-order dynamic equations on time scales. It seems that the results of this paper can be extended to cover the case of delay second-order dynamic equations.

## Acknowledgements

The authors would like to thank the anonymous referee for his/her valuable comments and good advice.

## REFERENCES

1. Adivar M., Raffoul Y.N. Existence of periodic solutions in totally nonlinear delay dynamic equations. *Electron. J. Qual. Theory Differ. Equ.*, 2009. Vol. 2009, No. 1. P. 1–20. DOI: [10.14232/ejqtde.2009.4.1](https://doi.org/10.14232/ejqtde.2009.4.1)
2. Ardjouni A., Djoudi A. Existence of positive periodic solutions for nonlinear neutral dynamic equations with variable delay on a time scale. *Malaya Journal of Matematik*, 2013. Vol. 2, No. 1. P. 60–67.
3. Ardjouni A., Djoudi A. Existence of periodic solutions for nonlinear neutral dynamic equations with functional delay on a time scale. *Acta Univ. Palack. Olomuc. Fac. Rerum Natur. Math.*, 2013. Vol. 52, No. 1. P. 5–19.
4. Ardjouni A., Djoudi A. Existence of periodic solutions for nonlinear neutral dynamic equations with variable delay on a time scale. *Commun. Nonlinear Sci. Numer. Simul.*, 2012. Vol. 17. P. 3061–3069. DOI: [10.1016/j.cnsns.2011.11.026](https://doi.org/10.1016/j.cnsns.2011.11.026)
5. Ardjouni A., Djoudi A. Periodic solutions in totally nonlinear dynamic equations with functional delay on a time scale. *Rend. Sem. Mat. Univ. Politec. Torino*, 2010. Vol. 68, No. 4. P. 349–359.
6. Bohner M., Peterson A. *Dynamic Equations on Time Scales, An Introduction with Applications*. Birkhäuser, Boston, 2001. 358 p. DOI: [10.1007/978-1-4612-0201-1](https://doi.org/10.1007/978-1-4612-0201-1)
7. Bohner M., Peterson A. *Advances in Dynamic Equations on Time Scales*. Birkhäuser, Boston, 2003. 348 p. DOI: [10.1007/978-0-8176-8230-9](https://doi.org/10.1007/978-0-8176-8230-9)
8. Bouchelaghem F., Ardjouni A., Djoudi A. Existence and stability of positive periodic solutions for delay nonlinear dynamic equations. *Nonlinear Stud.*, 2018. Vol. 25, No. 1. P. 191–202.
9. Bouchelaghem F., Ardjouni A., Djoudi A. Existence of positive solutions of delay dynamic equations. *Positivity*, 2017. Vol. 21, No. 4. P. 1483–1493. DOI: [10.1007/s11117-017-0480-2](https://doi.org/10.1007/s11117-017-0480-2)
10. Bouchelaghem F., Ardjouni A., Djoudi A. Existence of positive periodic solutions for delay dynamic equations. *Proyecciones (Antofagasta)*, 2017. Vol. 36, No. 3. P. 449–460. DOI: [10.4067/S0716-09172017000300449](https://doi.org/10.4067/S0716-09172017000300449)
11. Cid J.Á., Propst G., Tvrđý M. On the pumping effect in a pipe/tank flow configuration with friction. *Phys. D: Nonlinear Phenomena*, 2014. Vol. 273/274. P. 28–33. DOI: [10.1016/j.physd.2014.01.010](https://doi.org/10.1016/j.physd.2014.01.010)

12. Culáková I., Hanuštiaková L', Olach R. Existence for positive solutions of second-order neutral nonlinear differential equations. *Appl. Math. Lett.*, 2009. Vol. 22, No. 7. P. 1007–1010. DOI: [10.1016/j.aml.2009.01.009](https://doi.org/10.1016/j.aml.2009.01.009)
13. Dorociaková B., Michalková M., Olach R., Sága M. Existence and Stability of Periodic Solution Related to Valveless Pumping. *Math. Probl. Eng.*, 2018. Vol. 2018. Art. ID 3982432. P. 1–8. DOI: [10.1155/2018/3982432](https://doi.org/10.1155/2018/3982432)
14. Gouasmia M., Ardjouni A., Djoudi A. Periodic and nonnegative periodic solutions of nonlinear neutral dynamic equations on a time scale. *Int. J. Anal. Appl.*, 2018. Vol. 16, No. 2. P. 162–177. DOI: [10.28924/2291-8639-16-2018-162](https://doi.org/10.28924/2291-8639-16-2018-162)
15. Hilger S. *Ein Masskettenkalkül mit Anwendung auf Zentrumsmannigfaltigkeiten*. PhD thesis, Universität Würzburg, 1988.
16. Kaufmann E. R., Raffoul Y. N. Periodic solutions for a neutral nonlinear dynamical equation on a time scale. *J. Math. Anal. Appl.*, 2006. Vol. 319. P. 315–325. DOI: [10.1016/j.jmaa.2006.01.063](https://doi.org/10.1016/j.jmaa.2006.01.063)
17. Lakshmikantham V., Sivasundaram S., Kaymarkalan B. *Dynamic Systems on Measure Chains*. Dordrecht: Kluwer Academic Publishers, 1996. 294 p. DOI: [10.1007/978-1-4757-2449-3](https://doi.org/10.1007/978-1-4757-2449-3)
18. Smart D. R. *Fixed Points Theorems*. Cambridge, UK: Cambridge Univ. Press, 1980. 104 p.

# ASYMPTOTIC ALMOST AUTOMORPHY OF FUNCTIONS AND DISTRIBUTIONS

**Chikh Bouzar**

Laboratory of Mathematical Analysis and Applications, University of Oran 1,  
Ahmed Ben Bella, 31000, Oran, Algeria  
[ch.bouzar@gmail.com](mailto:ch.bouzar@gmail.com)

**Fatima Zahra Tchouar**

University Center of Ain Temouchent, 46000 Ain Temouchent, Algeria  
[fatima.tchouar@gmail.com](mailto:fatima.tchouar@gmail.com)

**Abstract:** This work aims to introduce and to study asymptotic almost automorphy in the context of Sobolev–Schwartz distributions. Applications to linear ordinary differential equation and neutral difference differential equations are also given.

**Keywords:** Asymptotically almost automorphic functions, Asymptotically almost automorphic distributions, Neutral difference differential equations.

## 1. Introduction

The paper aims to study asymptotic almost automorphy in the context of functions and Sobolev–Schwartz distributions, it is well known that the concept of almost automorphy is strictly more general than the almost periodicity studied in a full generality by H. Bohr, see [4] and [8]. The concept of asymptotic almost periodicity as a perturbation of almost periodic functions by functions that vanish at infinity belongs to M. Fréchet in [9], one of the main motives of which is the introduction of this concept in obtaining the existence of an almost periodic solution to differential equations if they admit an asymptotic almost periodic solution. In the same vein as Fréchet motivation, we study the existence of solutions of linear neutral difference differential equations with variable coefficients in the framework of asymptotically almost automorphic distributions. Almost periodicity in the framework of distributions extending the classical Bohr and Stepanov almost periodicity [16] is considered by L. Schwartz [13]. The paper [7] deals with asymptotic almost periodicity of distributions.

In [1] and [3], S. Bochner defined explicitly almost automorphic functions, where some basic properties have been established. He studied linear difference differential equations in the framework of almost automorphic functions in [2]. Almost automorphy of primitives and asymptotically almost automorphic functions are also considered, see [12, 18].

We first investigated the almost automorphy in the settings of distributions and generalized functions respectively in [6] and [5], then we addressed the issue of asymptotic almost automorphy in these contexts, see the communication [17].

The paper is organized as follows: the second section studies asymptotically almost automorphic functions following an appropriate definition, essential properties of these functions are proved; the third section deals with smooth asymptotically almost automorphic functions. The fourth section is dedicated to asymptotically almost automorphic distributions; we give their definition,

characterizations and some of their properties. The last section is an application to linear neutral difference differential equations of asymptotically almost automorphic distributions.

## 2. Asymptotically almost automorphic functions

It is worth noting that the definition of an asymptotically almost automorphic function depends on the choice of authors, but in general the essential idea of the decomposition in the definition of an asymptotically almost automorphic function is preserved. The differences in their definitions lie in the domain of definition of the considered functions, their regularity and finally in the choice of the interval of decomposition. We consider functions defined, continuous and bounded on the whole space of real numbers  $\mathbb{R}$  and the decomposition on the closed interval  $[0, +\infty[$ . So, we have to precise some results on asymptotically almost automorphic functions. Let  $\mathcal{C}_b$  denotes the space of bounded and continuous complex-valued functions defined on  $\mathbb{R}$ , endowed with the norm  $\|\cdot\|_\infty$  of uniform convergence on  $\mathbb{R}$ , it is well-known that  $(\mathcal{C}_b, \|\cdot\|_\infty)$  is a Banach algebra. Let  $\omega \in \mathbb{R}$  and  $f, \varphi$  functions, we recall that the translation operator  $\tau_\omega$  is defined by  $\tau_\omega f(\cdot) = f(\cdot + \omega)$ , and  $\check{\varphi}$  by  $\check{\varphi}(x) = \varphi(-x)$ . Denote  $\mathbb{J} := [0, +\infty[$ .

**Definition 1.** *The space  $\mathcal{C}_{+,0}$  is the set of all bounded and continuous complex-valued functions defined on  $\mathbb{R}$  and vanishing at  $+\infty$ .*

We give some properties of the space  $\mathcal{C}_{+,0}$  which are proved in a straight way.

**Proposition 1.** *The following is true:*

- (1) *The space  $\mathcal{C}_{+,0}$  is a Banach subalgebra of  $\mathcal{C}_b$ .*
- (2)  *$\tau_\omega \mathcal{C}_{+,0} \subset \mathcal{C}_{+,0}$ ,  $\forall \omega \in \mathbb{R}$ .*
- (3)  *$\mathcal{C}_{+,0} \times \mathcal{C}_b \subset \mathcal{C}_{+,0}$ .*
- (4)  *$\mathcal{C}_{+,0} * L^1 \subset \mathcal{C}_{+,0}$ .*
- (5) *Let  $h \in \mathcal{C}_{+,0}$ , if  $h'$  exists and is uniformly continuous on  $\mathbb{J}$ , then there exists a function  $H \in \mathcal{C}_{+,0}$  such that  $H = h'$  on  $\mathbb{J}$ .*
- (6) *There exists  $H \in \mathcal{C}_{+,0}$  a primitive of  $h$  on  $\mathbb{J}$  if and only if  $\int_0^{+\infty} h(t) dt < \infty$  and  $\int_0^x h(t) dt$  is bounded on  $\mathbb{J}$ .*

*Remark 1.* In (5) if  $h'$  exists and is uniformly continuous on  $\mathbb{R}$ , then  $H = h'$  on  $\mathbb{R}$ .

*Remark 2.* If  $h$  is a locally integrable function, we denote by  $\int_0^{+\infty} h(t) dt$  the improper integral, and  $\int_0^{+\infty} h(t) dt < \infty$  means  $\int_0^{+\infty} h(t) dt$  is finite.

Recall some properties of almost automorphic functions, see [1, 3, 12, 18].

**Definition 2.** *A complex-valued function  $g$  defined and continuous on  $\mathbb{R}$  is called almost automorphic if for any sequence  $(s_m)_{m \in \mathbb{N}} \subset \mathbb{R}$ , one can extract a subsequence  $(s_{m_k})_k$  such that*

$$\tilde{g}(x) := \lim_{k \rightarrow +\infty} g(x + s_{m_k}) \quad \text{exists for every } x \in \mathbb{R},$$



and

$$\lim_{k \rightarrow +\infty} \tilde{g}(x - s_{m_k}) = g(x) \quad \text{for every } x \in \mathbb{R}.$$

The space of almost automorphic functions on  $\mathbb{R}$  is denoted by  $\mathcal{C}_{aa}$ .

*Remark 3.* The function  $\tilde{g}$  is not necessary continuous but  $\tilde{g} \in L^\infty(\mathbb{R})$ .

**Proposition 2.** *The following is true:*

- (1) The space  $\mathcal{C}_{aa}$  is a Banach subalgebra of  $\mathcal{C}_b$ .
- (2)  $\tau_\omega \mathcal{C}_{aa} \subset \mathcal{C}_{aa}$ ,  $\forall \omega \in \mathbb{R}$ .
- (3)  $\mathcal{C}_{aa} * L^1 \subset \mathcal{C}_{aa}$ .
- (4)  $\mathcal{C}_{aa} \cap \mathcal{C}_{+,0} = \{0\}$ .
- (5) A primitive of an almost automorphic function is almost automorphic if and only if it is bounded.

We give now the definition of an asymptotically almost automorphic function.

**Definition 3.** *We say that a function  $f \in \mathcal{C}_b$  is asymptotically almost automorphic, if there exist  $g \in \mathcal{C}_{aa}$  and  $h \in \mathcal{C}_{+,0}$  such that  $f = g + h$  on  $\mathbb{J}$ . The space of asymptotically almost automorphic functions is denoted by  $\mathcal{C}_{aaa}$ .*

*Example 1.*  $\mathcal{C}_{aa} \subset \mathcal{C}_{aaa}$  and  $\mathcal{C}_{+,0} \subset \mathcal{C}_{aaa}$ .

It can be seen easily that the decomposition of an asymptotically almost automorphic function is unique on  $\mathbb{J}$ , so if  $f \in \mathcal{C}_{aaa}$  and  $f = g + h$  on  $\mathbb{J}$ , where  $g \in \mathcal{C}_{aa}$  and  $h \in \mathcal{C}_{+,0}$ , the function  $g$  is said the principal term of  $f$  and the function  $h$  is the corrective term of  $f$ , we denote them respectively by  $f_{aa}$  and  $f_{cor}$ . Then the notation  $f = (f_{aa} + f_{cor}) \in \mathcal{C}_{aaa}$  means that  $f_{aa} \in \mathcal{C}_{aa}$ ,  $f_{cor} \in \mathcal{C}_{+,0}$  and  $f = f_{aa} + f_{cor}$  on  $\mathbb{J}$ .

**Proposition 3.** *The following is true:*

- (1)  $\tau_\omega \mathcal{C}_{aaa} \subset \mathcal{C}_{aaa}$ ,  $\forall \omega \in \mathbb{R}_+$ .
- (2)  $\mathcal{C}_{aaa} \times \mathcal{C}_{aa} \subset \mathcal{C}_{aaa}$ .
- (3)  $\mathcal{C}_{aaa} * L^1 \subset \mathcal{C}_{aaa}$ .
- (4) Let  $f \in \mathcal{C}_{aaa}$  and  $\phi$  is a continuous function on  $\mathbb{C}$ , then  $\phi \circ f \in \mathcal{C}_{aaa}$ .
- (5) If  $f = (f_{aa} + f_{cor}) \in \mathcal{C}_{aaa}$ , then  $\|f_{aa}\|_\infty \leq \sup_{x \in \mathbb{J}} |f(x)|$ . In particular, for  $f \in \mathcal{C}_{aa}$  and  $\omega \in \mathbb{R}$ ,  $\|f\|_\infty = \sup_{x \geq \omega} |f(x)|$ .
- (6) Let  $(f_m)_{m \in \mathbb{N}} = (f_{m,aa} + f_{m,cor})_m \subset \mathcal{C}_{aaa}$  converges uniformly on  $\mathbb{J}$  to a function  $f$ , then there exists  $\phi = (g + h) \in \mathcal{C}_{aaa}$ , such that  $\phi = f$  on  $\mathbb{J}$ ,  $g \in \mathcal{C}_{aa}$  is the uniform limit on  $\mathbb{R}$  of  $(f_{m,aa})_m$  and  $h \in \mathcal{C}_{+,0}$  is the uniform limit on  $\mathbb{J}$  of  $(f_{m,cor})_m$ .

P r o o f. The proofs of (1) and (2) are easy.

(3) Let  $\psi \in L^1$  and  $f = (f_{aa} + f_{cor}) \in \mathcal{C}_{aaa}$ . Since  $f = f_{aa} + (f - f_{aa})$ , where  $(f - f_{aa}) \in \mathcal{C}_{+,0}$ , it follows from Proposition 2–(3) and Proposition 1–(4) that  $f * \psi \in \mathcal{C}_{aaa}$ . Now we show explicitly the principal part and the corrective part of  $f * \psi$ . For  $x \in \mathbb{J}$ , we have

$$\begin{aligned} (f * \psi)(x) &= \int_{\mathbb{R}} f(y) \psi(x-y) dy = \int_{-\infty}^0 f(y) \psi(x-y) dy + \int_0^{+\infty} (f_{aa}(y) + f_{cor}(y)) \psi(x-y) dy, \\ &= (f_{aa} * \psi)(x) + (f_{cor} * \psi)(x) + \int_{-\infty}^0 (f - f_{aa} - f_{cor})(y) \psi(x-y) dy. \end{aligned}$$

By Proposition 2–(3),  $(f_{aa} * \psi) \in \mathcal{C}_{aa}$  and by Proposition 1–(4),  $(f_{cor} * \psi) \in \mathcal{C}_{+,0}$ . On the other hand, for  $x \in \mathbb{R}$ ,

$$\int_{-\infty}^0 (f - f_{aa} - f_{cor})(y) \psi(x-y) dy = \int_{\mathbb{R}} (f - f_{aa} - f_{cor})(x-y) \chi_{]x,+\infty[}(y) \psi(y) dy.$$

It is easy to see that the latter function is continuous and bounded on  $\mathbb{R}$  and by the dominated convergence theorem it vanishes at infinity. Then  $f * \psi = (\Psi_{aa} + \Psi_{cor}) \in \mathcal{C}_{aaa}$ , where  $\Psi_{aa} := f_{aa} * \psi$  and  $\Psi_{cor} := f_{cor} * \psi + \int_{-\infty}^0 (f - f_{aa} - f_{cor})(y) \psi(\cdot - y) dy$ .

(4) Let  $f = (f_{aa} + f_{cor}) \in \mathcal{C}_{aaa}$  and  $\phi$  be a continuous function on  $\mathbb{C}$ , then it is well-known that  $\phi(f) \in \mathcal{C}_b$  and also  $\phi(f_{aa}) \in \mathcal{C}_{aa}$ . On the other hand, it is easy to see that the function  $\phi(f) - \phi(f_{aa})$  defined on  $\mathbb{R}$  belongs to  $\mathcal{C}_{+,0}$ . Consequently we have  $\phi(f) = (\phi(f))_{aa} + \phi(f)_{cor} \in \mathcal{C}_{aaa}$ , where  $\phi(f)_{aa} = \phi(f_{aa})$  and  $\phi(f)_{cor} = \phi(f) - \phi(f_{aa})$ .

(5) Let  $f = (f_{aa} + f_{cor}) \in \mathcal{C}_{aaa}$  and  $(s_{m_k})_k$  a subsequence of  $(s_m)_{m \in \mathbb{N}} \subset \mathbb{J}$  which tends to infinity. Let  $x \in \mathbb{R}$  and  $k_0 \in \mathbb{Z}_+$  such that the sequence  $(x + s_{m_k})_{k \geq k_0} \subset \mathbb{J}$  tends to infinity, then for  $k \geq k_0$ , we have

$$|f_{aa}(x + s_{m_k})| \leq |f(x + s_{m_k})| + |f_{cor}(x + s_{m_k})| \leq \sup_{x \in \mathbb{J}} |f(x)| + |f_{cor}(x + s_{m_k})|$$

so  $\forall x \in \mathbb{R}$ ,

$$|\tilde{f}_{aa}(x)| = \lim_{k \rightarrow +\infty} |f_{aa}(x + s_{m_k})| \leq \sup_{x \in \mathbb{J}} |f(x)|.$$

It follows then

$$|f_{aa}(x)| = \lim_{k \rightarrow +\infty} |\tilde{f}_{aa}(x - s_{m_k})| \leq \sup_{x \in \mathbb{J}} |f(x)|, \quad \forall x \in \mathbb{R}.$$

Consequently, we obtain the results.

(6) Let  $(f_m)_m = (f_{m,aa} + f_{m,cor})_m \subset \mathcal{C}_{aaa}$  converges uniformly to  $f$  on  $\mathbb{J}$ , by (5) we have

$$\|f_{n,aa} - f_{m,aa}\|_{\infty} \leq \sup_{x \in \mathbb{J}} |f_n(x) - f_m(x)|,$$

hence  $(f_{m,aa})_{m \in \mathbb{N}}$  is a Cauchy sequence in the Banach space  $\mathcal{C}_{aa}$ , i.e.  $(f_{m,aa})$  converges uniformly on  $\mathbb{R}$  to a function  $g \in \mathcal{C}_{aa}$ . Let's define the function  $h$  by

$$h(x) = \begin{cases} (f - g)(x), & x \geq 0, \\ (f - g)(0), & x < 0. \end{cases}$$

Then  $h \in \mathcal{C}_b$  and  $(f_{m,cor})_m$  converges uniformly on  $\mathbb{J}$  to  $h$ , i.e.  $\lim_{x \rightarrow +\infty} h(x) = 0$  hence  $h \in \mathcal{C}_{+,0}$ . Define  $\phi = g + h$  on  $\mathbb{R}$ , then  $\phi \in \mathcal{C}_{aaa}$  and  $\phi = f$  on  $\mathbb{J}$ .  $\square$

The space  $(\mathcal{C}_{aaa}, \|\cdot\|_\infty)$  is complete and it is a consequence of point (6).

**Corollary 1.** *The space  $(\mathcal{C}_{aaa}, \|\cdot\|_\infty)$  is a Banach subalgebra of  $\mathcal{C}_b$ .*

We have the following results on the derivative and the primitive.

**Proposition 4.** *The following is true:*

- (1) *Let  $f = (f_{aa} + f_{cor}) \in \mathcal{C}_{aaa}$  be such that  $f'$  exists and is uniformly continuous on  $\mathbb{J}$ , then there exists  $\phi = (g + h) \in \mathcal{C}_{aaa}$ , such that  $\phi = f'$  on  $\mathbb{J}$ ,  $(f_{aa})' = g$  on  $\mathbb{R}$  and  $(f_{cor})' = h$  on  $\mathbb{J}$ .*
- (2) *Let  $f = (f_{aa} + f_{cor}) \in \mathcal{C}_{aaa}$  be such that  $f$  is uniformly continuous on  $\mathbb{J}$ , then there exists  $F \in \mathcal{C}_{aaa}$  being a primitive of  $f$  on  $\mathbb{J}$  if and only if  $\int_0^x f_{aa}(t) dt$  is bounded on  $\mathbb{R}$ ,  $\int_0^x f_{cor}(t) dt$  is bounded on  $\mathbb{J}$ , and  $\int_0^{+\infty} f_{cor}(t) dt < \infty$ .*

**P r o o f.** (1) Let  $(\sigma_m)_{m \in \mathbb{N}} \subset \mathbb{J}$  converging to zero and define the sequence  $(\phi_m)_{m \in \mathbb{N}} \subset \mathcal{C}_{aaa}$  by

$$\begin{aligned} \phi_m(x) &= \frac{f(x + \sigma_m) - f(x)}{\sigma_m}, \quad x \in \mathbb{R} \\ &= \int_0^1 f'(x + \theta\sigma_m) d\theta, \quad x \in \mathbb{J}. \end{aligned}$$

then the sequence  $(\phi_m)_m$  converges uniformly to  $f'$  on  $\mathbb{J}$  and for  $x \in \mathbb{J}$ ,

$$\phi_m(x) = \phi_{m,aa}(x) + \phi_{m,cor}(x),$$

where

$$\phi_{m,aa}(x) := \frac{f_{aa}(x + \sigma_m) - f_{aa}(x)}{\sigma_m}, \quad \phi_{m,cor}(x) := \frac{f_{cor}(x + \sigma_m) - f_{cor}(x)}{\sigma_m}.$$

By (1), there exists  $\phi = (g + h) \in \mathcal{C}_{aaa}$ , such that  $\phi = f'$  on  $\mathbb{J}$ ,  $g \in \mathcal{C}_{aa}$  is the uniform limit of  $(\phi_{m,aa})_m$  on  $\mathbb{R}$  and  $h \in \mathcal{C}_{+,0}$  is the uniform limit of  $(\phi_{m,cor})_m$  on  $\mathbb{J}$ . Hence  $(f_{aa})' := \lim_{m \rightarrow +\infty} \phi_{m,aa} = g$  on  $\mathbb{R}$  and  $(f_{cor})' := \lim_{m \rightarrow +\infty} \phi_{m,cor} = h$  on  $\mathbb{J}$ .

(2) If  $F = (F_{aa} + F_{cor}) \in \mathcal{C}_{aaa}$  is a primitive of  $f$  on  $\mathbb{J}$ , then  $F' = f$  is uniformly continuous on  $\mathbb{J}$ . By (2),  $(F_{aa})' \in \mathcal{C}_{aa}$ , there exists  $h \in \mathcal{C}_{+,0}$  such that  $(F_{cor})' = h$  on  $\mathbb{J}$  and  $F' = (F_{aa})' + (F_{cor})'$  on  $\mathbb{J}$ . Consequently, by Proposition 1–(6) and Proposition 2–(5), we obtain the result. Conversely, as  $\int_0^{+\infty} f_{cor}(t) dt < \infty$  and  $\int_0^x f_{cor}(t) dt$  is bounded on  $\mathbb{J}$ , by Proposition 1–(6), there exists  $H \in \mathcal{C}_{+,0}$  which is a primitive on  $\mathbb{J}$  of  $f_{cor}$  and as  $\int_0^x f_{aa}(t) dt$  is bounded on  $\mathbb{R}$ , by Proposition 2–(5), there exists  $G \in \mathcal{C}_{aa}$  which is a primitive on  $\mathbb{R}$  of  $f_{aa}$ , so  $F := G + H$  is a primitive on  $\mathbb{J}$  of  $f$ .  $\square$

**Corollary 2.** *Let  $f = (f_{aa} + f_{cor}) \in \mathcal{C}_{aaa}$  such that  $f'$  exists and is uniformly continuous on  $\mathbb{R}$ , then  $f' = (g + h) \in \mathcal{C}_{aaa}$ , where  $(f_{aa})' = g$  on  $\mathbb{R}$  and  $(f_{cor})' = h$  on  $\mathbb{J}$ .*

### 3. Smooth asymptotically almost automorphic functions

Let  $\mathcal{E}(\mathbb{I})$  be the space of infinitely derivable functions on  $\mathbb{I} = \mathbb{R}$  or  $\mathbb{J}$ , and  $p \in [1, +\infty]$ , the space

$$\mathcal{D}_{L^p}(\mathbb{I}) := \{ \varphi \in \mathcal{E}(\mathbb{I}) : \forall j \in \mathbb{Z}_+, \varphi^{(j)} \in L^p(\mathbb{I}) \}$$

endowed with the topology defined by the family of seminorms

$$|\varphi|_{k,p,\mathbb{I}} := \sum_{j \leq k} \|\varphi^{(j)}\|_{L^p(\mathbb{I})}, \quad k \in \mathbb{Z}_+,$$

is a Fréchet subalgebra of  $\mathcal{E}(\mathbb{I})$ . The spaces  $\mathcal{D}_{L^p}(\mathbb{I})$  studied in [13] are connected with the classical Sobolev spaces  $W^{m,p}(\mathbb{I})$ , see [15]. We denote  $\mathcal{B}(\mathbb{I}) := \mathcal{D}_{L^\infty}(\mathbb{I})$ . Let  $\dot{\mathcal{B}}$  be the closure in  $\mathcal{B} := \mathcal{B}(\mathbb{R})$  of the space  $\mathcal{D}$  of smooth functions with compact support.

*Remark 4.* By the definition  $\varphi \in \mathcal{B}(\mathbb{J})$  requires that  $\lim_{x \rightarrow 0^+} \varphi^{(j)}(x)$  exists  $\forall j \in \mathbb{Z}_+$ .

Let  $\mathcal{B}_{+,0}$  be the space of smooth functions vanishing at infinity, i.e.

$$\mathcal{B}_{+,0} := \{ \varphi \in \mathcal{E}(\mathbb{R}) : \forall j \in \mathbb{Z}_+, \varphi^{(j)} \in \mathcal{C}_{+,0} \}.$$

We endow  $\mathcal{B}_{+,0}$  with the topology induced by  $\mathcal{B}$ .

**Proposition 5.** *The following is true:*

- (1) The space  $\mathcal{B}_{+,0}$  is a Fréchet subalgebra of  $\mathcal{B}$ .
- (2)  $\tau_\omega \mathcal{B}_{+,0} \subset \mathcal{B}_{+,0}$ ,  $\forall \omega \in \mathbb{R}$ .
- (3)  $\mathcal{B}_{+,0} \times \mathcal{B} \subset \mathcal{B}_{+,0}$ .
- (4)  $\mathcal{B}_{+,0} * L^1 \subset \mathcal{B}_{+,0}$ .
- (5)  $\mathcal{B}_{+,0} = \mathcal{C}_{+,0} \cap \mathcal{B}$ .
- (6) There exists  $H \in \mathcal{B}_{+,0}$  which is a primitive on  $\mathbb{J}$  of  $h \in \mathcal{B}_{+,0}$  if and only if  $\int_0^x h(t) dt$  is bounded on  $\mathbb{J}$  and  $\int_0^{+\infty} h(t) dt < \infty$ .

*P r o o f.* (1) It is easy to see that  $\mathcal{B}_{+,0}$  is an algebra and since  $\mathcal{B}$  is complete, it suffices to show that  $\mathcal{B}_{+,0}$  is closed. Let  $(h_m)_{m \in \mathbb{N}}$  be a sequence of  $\mathcal{B}_{+,0}$  that converges to  $h \in \mathcal{B}$ , i.e.  $\forall i \in \mathbb{Z}_+$ ,  $(h_m^{(i)})_m$  converges uniformly on  $\mathbb{R}$  to  $h^{(i)}$ . By Proposition 1–(1),  $h^{(i)} \in \mathcal{C}_{+,0}$ ,  $\forall i \in \mathbb{Z}_+$ , i.e.  $h \in \mathcal{B}_{+,0}$ .

(2) This inclusion is obvious.

(3) If  $\varphi \in \mathcal{B}$  and  $h \in \mathcal{B}_{+,0}$ , then by Leibniz's formula and Proposition 1–(3),  $\forall i \in \mathbb{Z}_+$ ,  $(h\varphi)^{(i)} \in \mathcal{C}_{+,0}$ .

(4) Let  $\psi \in L^1$  and  $h \in \mathcal{B}_{+,0}$ , then by Proposition 1–(4),  $\forall i \in \mathbb{Z}_+$ ,  $(h * \psi)^{(i)} = h^{(i)} * \psi \in \mathcal{C}_{+,0}$ .

(5) It is clear that  $\mathcal{B}_{+,0} \subset \mathcal{C}_{+,0} \cap \mathcal{B}$ . Conversely, if  $h \in \mathcal{C}_{+,0} \cap \mathcal{B}$ , then  $h'$  is uniformly continuous on  $\mathbb{R}$ , so by Remark 2,  $h' \in \mathcal{C}_{+,0}$ . By repeating this to all derivatives, we obtain that  $h \in \mathcal{B}_{+,0}$ .

(6) The necessity is a consequence of Proposition 1–(6). To prove the sufficiency we need the following preliminary result on extension operators, it can be obtained from [14]: there exist

two sequences of real numbers  $(a_l)_{l \in \mathbb{Z}_+}$  and  $(b_l)_{l \in \mathbb{Z}_+}$  such that  $b_l \leq 0, \forall l \in \mathbb{Z}_+$ , and the operator  $E : \mathcal{B}(\mathbb{J}) \rightarrow \mathcal{B}(\mathbb{R})$  defined by

$$Ef(x) := \begin{cases} f(x) & \text{if } x \geq 0, \\ \sum_{l=0}^{+\infty} a_l f(b_l x) & \text{if } x < 0 \end{cases}$$

is linear and continuous. Suppose that  $\int_0^x h(t) dt$  is bounded on  $\mathbb{J}$  and  $\int_0^{+\infty} h(t) dt < \infty$ . By Proposition 1-(6), there exists  $E \in \mathcal{C}_{+,0}$  such that  $E' = h$  on  $\mathbb{J}$ , so  $E$  is a smooth function on  $\mathbb{J}$  such that  $\forall i \in \mathbb{Z}_+$ ,  $E^{(i)}$  is bounded on  $\mathbb{J}$ , i.e.  $E \in \mathcal{B}(\mathbb{J})$ . Due to the extension result there exists a function  $H \in \mathcal{B}$  such that  $H = E$  on  $\mathbb{J}$ . So  $H \in \mathcal{B} \cap \mathcal{C}_{+,0} = \mathcal{B}_{+,0}$  and it is a primitive of  $h$  on  $\mathbb{J}$ .  $\square$

Recall the definition and some properties of the space of smooth almost automorphic functions, see [6] for details.

$$\mathcal{B}_{aa} := \{\varphi \in \mathcal{E} : \forall j \in \mathbb{Z}_+, \varphi^{(j)} \in \mathcal{C}_{aa}\}.$$

**Proposition 6.** *The following is true:*

- (1)  $\mathcal{B}_{aa}$  is a Fréchet subalgebra of  $\mathcal{B}$ .
- (2)  $\tau_\omega \mathcal{B}_{aa} \subset \mathcal{B}_{aa}, \forall \omega \in \mathbb{R}$ .
- (3)  $\mathcal{B}_{aa} * L^1 \subset \mathcal{B}_{aa}$ .
- (4)  $\mathcal{B}_{aa} = \mathcal{C}_{aa} \cap \mathcal{B}$ .
- (5) Let  $f \in \mathcal{B}_{aa}$  and  $F$  is its primitive on  $\mathbb{R}$ , then  $F \in \mathcal{B}_{aa}$  if and only if  $F$  is bounded.

We now introduce smooth asymptotically almost automorphic functions.

**Definition 4.** *The space of smooth asymptotically almost automorphic functions is denoted and defined by*

$$\mathcal{B}_{aaa} := \{\varphi \in \mathcal{E} : \forall j \in \mathbb{Z}_+, \varphi^{(j)} \in \mathcal{C}_{aaa}\}.$$

*Example 2.*  $\mathcal{B}_{aa} \subset \mathcal{B}_{aaa}$  and  $\mathcal{B}_{+,0} \subset \mathcal{B}_{aaa}$ .

We endow  $\mathcal{B}_{aaa}$  with the topology induced by  $\mathcal{B}$ . The following proposition is proved in the same way as Proposition 5 by using results of Propositions 3 and 4.

**Proposition 7.** *The following is true:*

- (1) The space  $\mathcal{B}_{aaa}$  is a Fréchet subalgebra of  $\mathcal{B}$ .
- (2)  $\tau_\omega \mathcal{B}_{aaa} \subset \mathcal{B}_{aaa}, \forall \omega \in \mathbb{R}$ .
- (3)  $\mathcal{B}_{aaa} \times \mathcal{B}_{aa} \subset \mathcal{B}_{aaa}$ .
- (4)  $\mathcal{B}_{aaa} * L^1 \subset \mathcal{B}_{aaa}$ .
- (5)  $\mathcal{B}_{aaa} = \mathcal{C}_{aaa} \cap \mathcal{B}$ .

- (6) There exists  $F \in \mathcal{B}_{aaa}$  being a primitive on  $\mathbb{J}$  of  $f \in \mathcal{B}_{aaa}$  if and only if  $\int_0^x f_{aa}(t) dt$  is bounded on  $\mathbb{R}$ ,  $\int_0^x f_{cor}(t) dt$  is bounded on  $\mathbb{J}$ ,  $\int_0^{+\infty} f_{cor}(t) dt < \infty$ .

*Remark 5.*  $\mathcal{B}_{aaa} \subsetneq \mathcal{C}_{aaa} \cap \mathcal{E}$ .

We have the following result needed in the sequel.

**Proposition 8.** Let  $f \in \mathcal{B}_{aaa}$ , i.e.  $f = f_{aa} + f_{cor}$  and for  $i \in \mathbb{N}$ ,  $f^{(i)} = f_{aa,i} + f_{cor,i}$  on  $\mathbb{J}$ . Then  $f_{aa,i} = (f_{aa})^{(i)}$  on  $\mathbb{R}$  and  $f_{cor,i} = (f_{cor})^{(i)}$  on  $\mathbb{J}$ .

*P r o o f.* If  $f \in \mathcal{B}_{aaa}$ , then  $f'$  is uniformly continuous on  $\mathbb{R}$  and by Proposition 4–(2), we have  $f' = (f_{aa})' + h$  on  $\mathbb{J}$ , where  $(f_{aa})' \in \mathcal{C}_{aa}$ ,  $h \in \mathcal{C}_{+,0}$  and  $(f_{cor})' = h$  on  $\mathbb{J}$ . By hypothesis,  $f' = f_{aa,1} + f_{cor,1}$  on  $\mathbb{J}$  and since the decomposition of an asymptotically almost automorphic function is unique, then  $(f_{aa})' = f_{aa,1}$  on  $\mathbb{R}$  and  $(f_{cor})' = f_{cor,1}$  on  $\mathbb{J}$ . By repeating this to all derivative, we obtain the desired result.  $\square$

In order to prove the main result on linear neutral difference differential equations in the framework of asymptotically almost automorphic distributions, we need the following characterization of the space  $\mathcal{B}_{aa}$ .

**Proposition 9.** Let  $g \in \mathcal{E}$ , the following statements are equivalent:

- (1)  $g \in \mathcal{B}_{aa}$ .
- (2) For every sequence  $(\rho_m)_{m \in \mathbb{N}} \subset \mathbb{R}$  there exist a subsequence  $(\rho_{m_k})_k$  and  $\tilde{g} \in \mathcal{B}$  such that for all  $x \in \mathbb{R}$  and  $i \in \mathbb{Z}_+$ , we have

$$\tilde{g}^{(i)}(x) = \lim_{k \rightarrow +\infty} g^{(i)}(x + \rho_{m_k}) \quad \text{and} \quad \lim_{k \rightarrow +\infty} \tilde{g}^{(i)}(x - \rho_{m_k}) = g^{(i)}(x). \quad (3.1)$$

*P r o o f.* (1)  $\Rightarrow$  (2) Let  $g \in \mathcal{B}_{aa}$ , so  $\forall i \in \mathbb{Z}_+$ ,  $\forall (\rho_m)_{m \in \mathbb{N}} \subset \mathbb{R}$ ,  $\exists (\rho_{m_{i,k}})_k \subset (\rho_m)_m$ ,  $\exists (\tilde{g}_i)_i \subset L^\infty$  such that  $\forall x \in \mathbb{R}$ ,

$$\lim_{k \rightarrow +\infty} g^{(i)}(x + \rho_{m_{i,k}}) =: \tilde{g}_i(x) \quad \text{and} \quad \lim_{k \rightarrow +\infty} \tilde{g}_i(x - \rho_{m_{i,k}}) = g^{(i)}(x).$$

There exist subsequences  $(\rho_{m_{n,k}})_k, n \in \mathbb{Z}_+$ , of the sequence  $(\rho_m)_m$  such that

$$\forall i \leq n, \quad \lim_{k \rightarrow +\infty} g^{(i)}(x + \rho_{m_{n,k}}) = \tilde{g}_i(x), \quad \forall x \in \mathbb{R}. \quad (3.2)$$

Indeed, the proof is done by induction, if  $g \in \mathcal{C}_{aa}$  it is clear that (3.2) holds for  $n = 0$ . Now, let  $n \in \mathbb{N}$  such that (3.2) holds. As  $g^{(n+1)} \in \mathcal{C}_{aa}$ , there exists a subsequence  $(\rho_{m_{(n+1),k}})_k$  of  $(\rho_{m_{n,k}})_k$  and  $\tilde{g}_{n+1} \in L^\infty$  such that  $\forall x \in \mathbb{R}$ ,

$$\tilde{g}_{n+1}(x) := \lim_{k \rightarrow +\infty} g^{(n+1)}(x + \rho_{m_{(n+1),k}}).$$

Furthermore, as  $\forall i \leq n$ ,  $\forall x \in \mathbb{R}$ , the subsequence  $(g^{(i)}(x + \rho_{m_{(n+1),k}}))_k$  is extracted from  $(g^{(i)}(x + \rho_{m_{n,k}}))_k$  then

$$\lim_{k \rightarrow +\infty} g^{(i)}(x + \rho_{m_{(n+1),k}}) = \tilde{g}_i(x), \quad \forall x \in \mathbb{R}.$$

By construction,  $\forall k, i \in \mathbb{Z}_+$ ,  $m_{i,k} \leq m_{(i+1),k}$  and since  $k \mapsto m_{(i+1),k}$  is strictly increasing from  $\mathbb{N}$  to  $\mathbb{N}$ , then in particular we have  $m_{i,i} \leq m_{(i+1),i} < m_{(i+1),(i+1)}$ ,  $\forall i \in \mathbb{Z}_+$ . This gives that the map  $k \mapsto m_{k,k}$  is strictly increasing from  $\mathbb{N}$  to  $\mathbb{N}$ . The sequence  $(\rho_{m_{k,k}})_k$ , which we denote by  $(\rho_{m_k})_k$ , is extracted from the subsequences  $(\rho_{m_{i,k}})_k$ ,  $i \in \mathbb{Z}_+$ , which is in fact extracted from the sequence  $(\rho_m)_m$ . Consequently,

$$\lim_{k \rightarrow +\infty} g^{(i)}(x + \rho_{m_k}) = \tilde{g}_i(x) \quad \text{exists} \quad \forall x \in \mathbb{R}, \quad \forall i \in \mathbb{Z}_+.$$

With the same steps we have that

$$\lim_{k \rightarrow +\infty} \tilde{g}_i(x - \rho_{m_k}) = g^{(i)}(x), \quad \forall x \in \mathbb{R}, \quad \forall i \in \mathbb{Z}_+.$$

Let  $(\sigma_n)_{n \in \mathbb{N}} \subset \mathbb{J}$  converging to zero and consider the sequence of functions  $(\phi_{n,k})_{n,k \in \mathbb{N}}$  defined on  $\mathbb{R}$  by the equality

$$\phi_{n,k}(\cdot) = \frac{g(\cdot + \rho_{m_k} + \sigma_n) - g(\cdot + \rho_{m_k})}{\sigma_n} = \int_0^1 g'(\cdot + \rho_{m_k} + \theta \sigma_n) d\theta.$$

Since  $g \in \mathcal{B}_{aa} \subset \mathcal{B}$ , then  $g'$  is bounded and uniformly continuous on  $\mathbb{R}$ , so

$$\lim_{k \rightarrow +\infty} \lim_{n \rightarrow +\infty} \int_0^1 g'(\cdot + \rho_{m_k} + \theta \sigma_n) d\theta = \lim_{n \rightarrow +\infty} \lim_{k \rightarrow +\infty} \int_0^1 g'(\cdot + \rho_{m_k} + \theta \sigma_n) d\theta.$$

Consequently,  $\forall x \in \mathbb{R}$ ,  $\lim_{k \rightarrow +\infty} \lim_{n \rightarrow +\infty} \phi_{n,k}(x) = \lim_{n \rightarrow +\infty} \lim_{k \rightarrow +\infty} \phi_{n,k}(x)$  which gives that  $\forall x \in \mathbb{R}$ ,

$$\tilde{g}_1(x) = \lim_{k \rightarrow +\infty} \lim_{n \rightarrow +\infty} \phi_{n,k}(x) = \lim_{n \rightarrow +\infty} \lim_{k \rightarrow +\infty} \phi_{n,k}(x) := \tilde{g}'_0(x).$$

By iterating to all derivatives, we obtain that  $\tilde{g}_0 \in \mathcal{E}$  and  $\tilde{g}_0^{(i)} = \tilde{g}_i \in L^\infty$ ,  $\forall i \in \mathbb{Z}_+$ , i.e.  $\tilde{g}_0 \in \mathcal{B}$  such that relations (3.1) hold.

(2)  $\Rightarrow$  (1) is obvious. □

#### 4. Asymptotically almost automorphic distributions

The space of  $L^p$ -distributions, denoted by  $\mathcal{D}'_{L^p}$ , is the topological dual of  $\mathcal{D}_{L^q}$ , where  $1/p + 1/q = 1$ . The topological dual of  $\mathcal{B}$  is denoted by  $\mathcal{D}'_{L^1}$ . The space of bounded distributions  $\mathcal{D}'_{L^\infty}$  is denoted by  $\mathcal{B}'$ . The translate  $\tau_\omega T$ ,  $\omega \in \mathbb{R}$ , of a distribution  $T \in \mathcal{D}'$  is defined by  $\langle \tau_\omega T, \varphi \rangle = \langle T, \tau_{-\omega} \varphi \rangle$ ,  $\forall \varphi \in \mathcal{D}$ .

**Definition 5.** By  $\mathcal{B}'_{+,0}$  we denote the space of distributions  $Q \in \mathcal{B}'$  vanishing at infinity, i.e. satisfying

$$\lim_{\omega \rightarrow +\infty} \langle \tau_\omega Q, \varphi \rangle = 0, \quad \forall \varphi \in \mathcal{D}.$$

We have the following characterizations of  $\mathcal{B}'_{+,0}$ , see [7].

**Theorem 1.** Let  $Q \in \mathcal{B}'$ , the following assertions are equivalent:

- (1)  $Q \in \mathcal{B}'_{+,0}$ .
- (2)  $Q * \varphi \in \mathcal{C}_{+,0}$ ,  $\forall \varphi \in \mathcal{D}$ .

(3)  $\exists k \in \mathbb{Z}_+$  and  $h_j \in \mathcal{C}_{+,0}$ ,  $0 \leq j \leq k$ , such that  $Q = \sum_{j=0}^k h_j^{(j)}$ .

We study some properties of the space  $\mathcal{B}'_{+,0}$ .

**Proposition 10.** *The following is true:*

- (1) If  $Q \in \mathcal{B}'_{+,0}$ , then  $Q^{(i)} \in \mathcal{B}'_{+,0}$ ,  $\forall i \in \mathbb{Z}_+$ .
- (2)  $\tau_\omega \mathcal{B}'_{+,0} \subset \mathcal{B}'_{+,0}$ ,  $\forall \omega \in \mathbb{R}$ .
- (3)  $\mathcal{B}'_{+,0} \times \mathcal{B} \subset \mathcal{B}'_{+,0}$ .
- (4)  $\mathcal{B}'_{+,0} * \mathcal{D}'_{L^1} \subset \mathcal{B}'_{+,0}$ .
- (5) Let  $Q \in \mathcal{B}'$ , then  $Q \in \mathcal{B}'_{+,0}$  if and only if there exists a sequence  $(\varphi_m)_{m \in \mathbb{N}} \subset \mathcal{B}_{+,0}$  converging to  $Q$  in  $\mathcal{B}'$ .

*P r o o f.* (1) and (2) are obvious.

(3) Let  $\varphi \in \mathcal{B}$  and  $Q \in \mathcal{B}'_{+,0}$ , then by Theorem 1–(3), there exist  $(h_i)_{i \leq k} \subset \mathcal{C}_{+,0}$ , such that  $Q = \sum_{i=0}^k h_i^{(i)}$ . So

$$\varphi Q = \sum_{i=0}^k \varphi h_i^{(i)} = \sum_{i=0}^k \sum_{j=0}^i (-1)^j \binom{i}{j} (\varphi^{(j)} h_i)^{(i-j)}.$$

By Proposition 1–(3),  $\varphi^{(j)} h_i \in \mathcal{C}_{+,0}$ , hence  $\varphi Q \in \mathcal{B}'_{+,0}$ .

(4) Let  $Q \in \mathcal{B}'_{+,0}$ , then there exists  $(h_i)_{i \leq k} \subset \mathcal{C}_{+,0}$  such that  $Q = \sum_{i=0}^k h_i^{(i)}$ , and let  $S \in \mathcal{D}'_{L^1}$ , by [13, Theorem XXV, Section 8, Chapter VI], there exist  $(\psi_j)_{j \leq m} \subset L^1$  such that  $S = \sum_{j=0}^m \psi_j^{(j)}$ . Thus

$$(Q * S) = \sum_{i=0}^k \sum_{j=0}^m (h_i * \psi_j)^{(i+j)}.$$

By Proposition 1–(4),  $h_i * \psi_j \in \mathcal{C}_{+,0}$ , hence  $Q * S \in \mathcal{B}'_{+,0}$ .

(5) Let  $(\phi_m)_{m \in \mathbb{N}} \subset \mathcal{B}_{+,0}$  such that  $\lim_{m \rightarrow +\infty} \phi_m = Q$  in  $\mathcal{B}'$ . For a fixed  $\varphi \in \mathcal{D}$ , the set

$$U := \{\tau_{-x} \check{\varphi} : x \in \mathbb{R}\}$$

is bounded in  $\mathcal{D}_{L^1}$ , so

$$\begin{aligned} \sup_{x \in \mathbb{R}} |(\phi_m * \varphi)(x) - (Q * \varphi)(x)| &= \sup_{x \in \mathbb{R}} |\langle \phi_m - Q, \tau_{-x} \check{\varphi} \rangle|, \\ &= \sup_{\psi \in U} |\langle \phi_m - Q, \psi \rangle| \xrightarrow{m \rightarrow +\infty} 0, \end{aligned}$$

i.e.  $(\phi_m * \varphi)_{m \in \mathbb{N}} \subset \mathcal{C}_{+,0}$  is uniformly convergent to  $(Q * \varphi)$ . By Proposition 1–(1),  $Q * \varphi \in \mathcal{C}_{+,0}$ ,  $\forall \varphi \in \mathcal{D}$ , and by Theorem 1, we obtain  $Q \in \mathcal{B}'_{+,0}$ .

Conversely, let  $Q \in \mathcal{B}'_{+,0}$  and take a sequence of positive test functions  $(\theta_m)_{m \in \mathbb{N}}$  such that

$$\text{supp } \theta_m \subset \left[0, \frac{1}{m}\right] \quad \text{and} \quad \int_{\mathbb{R}} \theta_m(x) dx = 1.$$



Define  $\phi_m := \theta_m * Q \in \mathcal{B}_{+,0}$ , we have

$$\langle \phi_m - Q, \varphi \rangle = \langle Q, \check{\theta}_m * \varphi - \varphi \rangle,$$

and there exist  $l \in \mathbb{Z}_+$ ,  $C > 0$  such that

$$|\langle Q, \check{\theta}_m * \varphi - \varphi \rangle| \leq C |\check{\theta}_m * \varphi - \varphi|_{l,1}, \quad \forall \varphi \in \mathcal{D}_{L^1}.$$

By Minkowski's inequality and the mean value theorem we obtain for  $t \in ]0, 1[$ ,

$$\begin{aligned} \|(\check{\theta}_m * \varphi)^{(i)} - \varphi^{(i)}\|_{L^1} &\leq \int_0^{1/m} \check{\theta}_m(y) \left( \int_{\mathbb{R}} |y| |\varphi^{(i+1)}(x + ty)| dx \right) dy \\ &\leq \int_0^{1/m} |y| \check{\theta}_m(y) \left( \int_{\mathbb{R}} |\varphi^{(i+1)}(z)| dz \right) dy \leq \frac{1}{m} \|\varphi^{(i+1)}\|_{L^1} \|\check{\theta}_m\|_{L^1}, \end{aligned}$$

so

$$|\check{\theta}_m * \varphi - \varphi|_{l,1} \leq \frac{1}{m} |\varphi|_{l+1,1}, \quad \forall \varphi \in \mathcal{D}_{L^1}.$$

Let  $U$  be a bounded set of  $\mathcal{D}_{L^1}$  and  $\varphi \in U$ , then  $\exists M > 0$  such that

$$\sup_{\varphi \in U} |\check{\theta}_m * \varphi - \varphi|_{l,1} \leq \frac{M}{m} \xrightarrow{m \rightarrow +\infty} 0,$$

which gives  $\theta_m \rightarrow Q$  in  $\mathcal{B}'$ . □

We recall the definition, characterizations and some properties of almost automorphic distributions, see [6].

**Definition 6.** A distribution  $T \in \mathcal{B}'$  is said almost automorphic if it satisfies one of the following equivalent conditions:

- (1)  $T * \varphi \in \mathcal{C}_{aa}$ ,  $\forall \varphi \in \mathcal{D}$ .
- (2)  $\exists k \in \mathbb{Z}_+$  and  $g_j \in \mathcal{C}_{aa}$ ,  $0 \leq j \leq k$ , such that  $T = \sum_{i=0}^k g_i^{(i)}$ .
- (3) For every sequence  $(s_m)_{m \in \mathbb{N}} \subset \mathbb{R}$ , there is a subsequence  $(s_{m_k})_k$  such that

$$S := \lim_{k \rightarrow +\infty} \tau_{s_{m_k}} T \text{ exists in } \mathcal{D}',$$

and

$$\lim_{k \rightarrow +\infty} \tau_{-s_{m_k}} S = T \text{ in } \mathcal{D}'.$$

- (4) There exists a sequence  $(\varphi_m)_{m \in \mathbb{N}} \subset \mathcal{B}_{aa}$  converging to  $T$  in  $\mathcal{B}'$ .

We denote by  $\mathcal{B}'_{aa}$  the space of almost automorphic distributions defined on  $\mathbb{R}$ .

**Proposition 11.** The following is true:

- (1) If  $T \in \mathcal{B}'_{aa}$ , then  $T^{(i)} \in \mathcal{B}'_{aa}$ ,  $\forall i \in \mathbb{Z}_+$ .

- (2)  $\tau_\omega \mathcal{B}'_{aa} \subset \mathcal{B}'_{aa}, \forall \omega \in \mathbb{R}$ .
- (3)  $\mathcal{B}'_{aa} \times \mathcal{B}_{aa} \subset \mathcal{B}'_{aa}$ .
- (4)  $\mathcal{B}'_{aa} * \mathcal{D}'_{L^1} \subset \mathcal{B}'_{aa}$ .
- (5)  $\mathcal{B}'_{aa} \cap \mathcal{B}'_{+,0} = \{0\}$ .

We now give the definition of asymptotically almost automorphic distributions.

**Definition 7.** A distribution  $T \in \mathcal{B}'$  is said asymptotically almost automorphic if there exist  $P \in \mathcal{B}'_{aa}$  and  $Q \in \mathcal{B}'_{+,0}$  such that  $T = P + Q$  on  $\mathbb{J}$ . We denote by  $\mathcal{B}'_{aaa}$  the space of asymptotically almost automorphic distributions.

*Remark 6.* The equality  $T = P + Q$  on  $\mathbb{J}$  means that  $\forall \varphi \in \mathcal{D}_+, \langle T, \varphi \rangle = \langle P, \varphi \rangle + \langle Q, \varphi \rangle$ , where  $\mathcal{D}_+ := \{\varphi \in \mathcal{D} : \text{supp } \varphi \subset \mathbb{J}\}$ .

**Proposition 12.** The decomposition of an asymptotically almost automorphic distribution is unique on  $\mathbb{J}$ .

*P r o o f.* Let  $P_1, P_2 \in \mathcal{B}'_{aa}$  and  $Q_1, Q_2 \in \mathcal{B}'_{+,0}$  such that  $T = P_1 + Q_1 = P_2 + Q_2$  on  $\mathbb{J}$ , then we obtain that  $P_1 - P_2 \in \mathcal{B}'_{+,0}$ , by Proposition 11–(5),  $P_1 - P_2 = 0$ . Hence  $Q_1 = Q_2$  on  $\mathbb{J}$ .  $\square$

**Notation 1.** If  $T \in \mathcal{B}'_{aaa}$  and  $T = P + Q$  on  $\mathbb{J}$ , we call  $P$  the principal term and  $R$  the corrective term of  $T$  and we denote them respectively by  $T_{aa}$  and  $T_{cor}$ . This is summarized by the notation  $T = (T_{aa} + T_{cor}) \in \mathcal{B}'_{aaa}$ .

*Example 3.*

1.  $\mathcal{C}_{aaa} \subset \mathcal{B}'_{aaa}$ .
2.  $\mathcal{B}'_{aa} \subset \mathcal{B}'_{aaa}$ .
3.  $\mathcal{B}'_{+,0} \subset \mathcal{B}'_{aaa}$ .
4.  $\mathcal{B}'_{aap} \subsetneq \mathcal{B}'_{aaa}$ , where  $\mathcal{B}'_{aap}$  is the space of asymptotically almost periodic distributions of [7].

The following results characterize asymptotically almost automorphic distributions.

**Theorem 2.** Let  $T \in \mathcal{B}'$ , the following assertions are equivalent:

- (1)  $T \in \mathcal{B}'_{aaa}$ .
- (2)  $\exists (\theta_m)_{m \in \mathbb{N}} \subset \mathcal{B}_{aaa}$  such that  $\lim_{n \rightarrow +\infty} \theta_m = T$  in  $\mathcal{B}'$ .
- (3)  $T * \varphi \in \mathcal{C}_{aaa}, \forall \varphi \in \mathcal{D}$ .
- (4)  $\exists k \in \mathbb{Z}_+$  and  $f_j \in \mathcal{C}_{aaa}, 0 \leq j \leq k$ , such that  $T = \sum_{j=0}^k f_j^{(j)}$ .

**P r o o f.** (1)  $\Rightarrow$  (2) Let  $T \in \mathcal{B}'_{aaa}$ , by definition  $T = T_{aa} + T_{cor}$  on  $\mathbb{J}$ . By the characterization of  $\mathcal{B}'_{aa}$  there exists  $(\varphi_m)_{m \in \mathbb{N}} \subset \mathcal{B}_{aa}$  such that  $\lim_{m \rightarrow +\infty} \varphi_m = T_{aa}$  in  $\mathcal{B}'$ . It is easy to prove that  $T - T_{aa} \in \mathcal{B}'_{+,0}$ , so by Proposition 10-(5) there exists  $(\psi_m)_{m \in \mathbb{N}} \subset \mathcal{B}_{+,0}$  such that  $\lim_{m \rightarrow +\infty} \psi_m = T - T_{aa}$  in  $\mathcal{B}'$ . Set  $\theta_m := \varphi_m + \psi_m, m \in \mathbb{N}$ , then  $(\theta_m)_{m \in \mathbb{N}} \subset \mathcal{B}_{aaa}$  and we have  $T - \theta_m = (T - T_{aa}) - \psi_m + (T_{aa} - \varphi_m)$ . Hence we obtain  $\lim_{n \rightarrow +\infty} \theta_m = T$  in  $\mathcal{B}'$ .

(2)  $\Rightarrow$  (3) As in the proof of Proposition 10-(5), if  $(\phi_m)_{m \in \mathbb{N}} \subset \mathcal{B}_{aaa}$  is such that  $\lim_{m \rightarrow +\infty} \phi_m = T$  in  $\mathcal{B}'$ , then for  $\forall \varphi \in \mathcal{D}$  we have

$$\sup_{x \in \mathbb{R}} |(\phi_m * \varphi)(x) - (T * \varphi)(x)| = \sup_{x \in \mathbb{R}} |\langle \phi_m - T, \tau_{-x} \check{\varphi} \rangle| \xrightarrow{m \rightarrow +\infty} 0.$$

That is  $(\phi_m * \varphi)_{m \in \mathbb{N}} \subset \mathcal{C}_{aaa}$  converges uniformly on  $\mathbb{R}$  to  $(T * \varphi)$ , it follows that  $T * \varphi \in \mathcal{C}_{aaa}$ ,  $\forall \varphi \in \mathcal{D}$ .

(3)  $\Rightarrow$  (4) For  $n \in \mathbb{Z}_+$ , consider the function

$$E_n(x) = \begin{cases} \frac{x^{n-1}}{(n-1)!}, & x \geq 0. \\ 0, & x < 0. \end{cases}$$

Then  $E_n \in \mathcal{C}^{n-2}$ ,  $\text{supp} E_n \subset \mathbb{J}$  and  $E_n^{(n)} = \delta$ . Take a function  $\gamma \in \mathcal{D}$  such that  $\gamma = 1$  in the neighborhood of 0, a direct calculus gives  $(\gamma E_n)^{(n)} = \delta + \zeta_n$ , where

$$\zeta_n = \sum_{k=0}^{n-1} \binom{n}{k} \gamma^{(n-k)} E_n^{(k)} \in \mathcal{D}.$$

As  $T \in \mathcal{B}'$ , we have

$$T = (\gamma E_n * T)^{(n)} - T * \zeta_n,$$

where  $T * \zeta_n \in \mathcal{C}_{aaa}$ . It remains to show that  $\gamma E_n * T \in \mathcal{C}_{aaa}$  for a suitable  $n$ . There exist  $m \in \mathbb{Z}_+$  and  $C > 0$  such that

$$|\langle T, \psi \rangle| \leq C |\psi|_{m,1}, \quad \forall \psi \in \mathcal{D}_{L^1}.$$

Take  $n = m + 2$ , then  $\gamma E_{m+2} \in \mathcal{D}_{L^1}^m$ , where

$$\mathcal{D}_{L^1}^m := \{\varphi \in \mathcal{C}^m : \forall j \leq m, \varphi^{(j)} \in L^1\} \text{ endowed with the norm } |\cdot|_{m,1}.$$

We have  $\mathcal{D} \hookrightarrow \mathcal{D}_{L^1} \hookrightarrow \mathcal{D}_{L^1}^m$  and there exists a sequence  $(\theta_k)_{k \in \mathbb{N}} \subset \mathcal{D}$  such that  $(\theta_k)_k$  converges to  $\gamma E_{m+2}$  with respect to the norm  $|\cdot|_{m,1}$ , so

$$\begin{aligned} |(T * \theta_k)(x) - (T * \gamma E_{m+2})(x)| &= |\langle T, \tau_{-x} \check{\theta}_k - \tau_{-x} (\check{\gamma} \check{E}_{m+2}) \rangle|, \\ &\leq C |\tau_{-x} \check{\theta}_k - \tau_{-x} (\check{\gamma} \check{E}_{m+2})|_{m,1}, \\ &\leq C |\theta_k - \gamma E_{m+2}|_{m,1}, \end{aligned}$$

consequently,

$$\sup_{x \in \mathbb{R}} |(T * \theta_k)(x) - (T * \gamma E_{m+2})(x)| \leq C |\theta_k - \gamma E_{m+2}|_{m,1} \xrightarrow{k \rightarrow +\infty} 0.$$

i.e. the sequence of functions  $(T * \theta_k)_{k \in \mathbb{N}} \subset \mathcal{C}_{aaa}$  converges uniformly on  $\mathbb{R}$  to  $T * \gamma E_{m+2}$ , hence  $T * \gamma E_{m+2} \in \mathcal{C}_{aaa}$ .

(4)  $\Rightarrow$  (1) Let  $T = \sum_{j=0}^k f_j^{(j)}$ , where  $f_j \in \mathcal{C}_{aaa}$ ,  $j = 0, \dots, k$ , so

$$T = \sum_{j=0}^k f_{j,aa}^{(j)} + \sum_{j=0}^k f_{j,cor}^{(j)} \quad \text{on } \mathbb{J}.$$

Then by Theorem 1 and Definition 6,  $P = \sum_{j=0}^k f_{j,aa}^{(j)} \in \mathcal{B}'_{aa}$  and  $Q = \sum_{j=0}^k f_{j,cor}^{(j)} \in \mathcal{B}'_{+,0}$ . Therefore  $T = P + Q$  on  $\mathbb{J}$ , i.e.  $T \in \mathcal{B}'_{aaa}$ .  $\square$

*Remark 7.* Connected with this theorem, let us quote the preprint [10]. The authors thank the referee for pointing out the recent work [11].

We have the following properties of  $\mathcal{B}'_{aaa}$ .

**Proposition 13.** *The following is true:*

- (1) If  $T \in \mathcal{B}'_{aaa}$ , then  $\forall i \in \mathbb{Z}_+$ ,  $T^{(i)} = (T_{aa}^{(i)} + T_{cor}^{(i)}) \in \mathcal{B}'_{aaa}$ .
- (2)  $\tau_\omega \mathcal{B}'_{aaa} \subset \mathcal{B}'_{aaa}$ ,  $\forall \omega \in \mathbb{R}_+$ .
- (3)  $\mathcal{B}'_{aaa} \times \mathcal{B}_{aa} \subset \mathcal{B}'_{aaa}$ .
- (4)  $\mathcal{B}'_{aaa} * \mathcal{D}'_{L^1} \subset \mathcal{B}'_{aaa}$ .

*P r o o f.* The proof of the assertions (1)–(3) follows from the definition, the uniqueness of the decomposition and the same properties satisfied by the space  $\mathcal{B}'_{aa}$ .

(4) Let  $T \in \mathcal{B}'_{aaa}$ , by the previous Theorem, there exist  $(f_i)_{i \leq k} \subset \mathcal{C}_{aaa}$  such that  $T = \sum_{i=0}^k f_i^{(i)}$ . Let  $S \in \mathcal{D}'_{L^1}$ , by [13, Theorem XXV, Section 8, Chapter VI], there exists  $(\psi_j)_{j \leq m} \subset L^1$  such that  $S = \sum_{j=0}^m \psi_j^{(j)}$ . Thus

$$(T * S) = \sum_{i=0}^k \sum_{j=0}^m (f_i * \psi_j)^{(i+j)}.$$

By Proposition 7–(4),  $f_i * \psi_j \in \mathcal{C}_{aaa}$ . By [13, Theorem XXVI, Section 8, Chapter VI] we have  $\mathcal{B}' * \mathcal{D}'_{L^1} \subset \mathcal{B}'$ , hence  $S * T \in \mathcal{B}'_{aaa}$ .  $\square$

## 5. Linear neutral difference differential equations

A linear neutral difference differential equation is an equation

$$L_\omega u := \sum_{i=0}^p \sum_{j=0}^q a_{ij} \frac{d^i}{dx^i} \tau_{\omega_j} u + K * u = f,$$

where  $(a_{ij})_{i \leq p, j \leq q} \subset \mathcal{B}_{aa}$ ,  $K \in L^1$  and  $\omega = (\omega_j)_{j \leq q} \subset \mathbb{R}_+^q$ .

By the properties of the space  $\mathcal{B}'_{aaa}$  it is clear that  $L_\omega \mathcal{B}'_{aaa} \subset \mathcal{B}'_{aaa}$ . To prove the main result of this section we need the following result.

**Lemma 1.** Let  $T \in \mathcal{B}'$ ,  $g, \tilde{g} \in \mathcal{B}$  and  $(s_m)_{m \in \mathbb{N}}$  a sequence of real numbers such that

$$\tilde{T} := \lim_{m \rightarrow +\infty} \tau_{s_m} T \quad \text{in } \mathcal{D}', \quad (5.1)$$

and

$$\tilde{g}^{(j)}(x) = \lim_{n \rightarrow +\infty} \tau_{s_m} g^{(j)}(x), \quad \forall x \in \mathbb{R}, \quad \forall j \in \mathbb{Z}_+, \quad (5.2)$$

then

$$\lim_{n \rightarrow +\infty} \tau_{s_m}(gT) = \tilde{g}\tilde{T} \quad \text{in } \mathcal{D}'.$$

*P r o o f.* Let  $(s_m)_{m \in \mathbb{N}}$ ,  $T \in \mathcal{B}'$  and  $g, \tilde{g} \in \mathcal{B}$  such that (5.1) and (5.2) hold. As  $T \in \mathcal{B}'$ ,  $\exists C > 0$ ,  $\exists l \in \mathbb{Z}_+$ , such that

$$|\langle T, \psi \rangle| \leq C \|\psi\|_{l,1}, \quad \forall \psi \in \mathcal{D}_{L^1}.$$

So  $\forall \varphi \in \mathcal{D}$ ,

$$\begin{aligned} |\langle \tau_{s_m}(gT) - \tilde{g}\tilde{T}, \varphi \rangle| &= |\langle T, g\tau_{-s_m}\varphi \rangle - \langle \tilde{T}, \tilde{g}\varphi \rangle|, \\ &= |\langle \tau_{s_m}T, \varphi\tau_{s_m}g \rangle - \langle \tilde{T}, \tilde{g}\varphi \rangle|, \\ &\leq |\langle \tau_{s_m}T - \tilde{T}, \tilde{g}\varphi \rangle| + |\langle \tau_{s_m}T, (\tau_{s_m}g - \tilde{g})\varphi \rangle|, \\ &\leq |\langle \tau_{s_m}T - \tilde{T}, \tilde{g}\varphi \rangle| + C \|(\tau_{s_m}g - \tilde{g})\varphi\|_{l,1}, \\ &\leq |\langle \tau_{s_m}T - \tilde{T}, \tilde{g}\varphi \rangle| + C \sum_{i=0}^l \|((\tau_{s_m}g - \tilde{g})\varphi)^{(i)}\|_{L^1}. \end{aligned}$$

The lemma is proved due to (5.1) and the following estimate

$$\|((\tau_{s_m}g - \tilde{g})\varphi)^{(i)}\|_{L^1} \leq \sum_{j=0}^i \binom{i}{j} \int_{\mathbb{R}} |g^{(j)}(x + s_m) - \tilde{g}^{(j)}(x)| |\varphi^{(i-j)}(x)| dx \xrightarrow{m \rightarrow \infty} 0,$$

which is due to the dominated convergence theorem.  $\square$

The main result of this section is the following.

**Theorem 3.** Let  $S \in \mathcal{B}'_{aaa}$ , the equation  $L_\omega T = S$  has a solution  $T \in \mathcal{B}'_{aaa}$  on  $\mathbb{J}$  if and only if there exist  $V \in \mathcal{B}'_{aa}$  and  $W \in \mathcal{B}'_{+,0}$ , such that

$$L_\omega V = S_{aa} \quad \text{on } \mathbb{R} \quad (5.3)$$

and

$$L_\omega W = S_{cor} \quad \text{on } \mathbb{J}. \quad (5.4)$$

*P r o o f.* Suppose that equations (5.3) and (5.4) are satisfied, then

$$L_\omega(V + W) = L_\omega V + L_\omega W = S_{aa} + S_{cor} = S \quad \text{on } \mathbb{J}.$$

So  $T = V + W \in \mathcal{B}'_{aaa}$  is a solution on  $\mathbb{J}$  of  $L_\omega T = S$ .

Conversely, let  $T \in \mathcal{B}'_{aaa}$  be a solution on  $\mathbb{J}$  of the equation  $L_\omega T = S$  and let  $(s_m)_{m \in \mathbb{N}}$  be a sequence of real numbers which converges to  $+\infty$ . As  $S_{aa}, T_{aa} \in \mathcal{B}'_{aa}$  and  $S_{cor}, T_{cor} \in \mathcal{B}'_{+,0}$ , and by Proposition 9, there is a subsequence  $(s_{m_k})_k$  of  $(s_m)$  converging to  $+\infty$  and functions  $\tilde{a}_{ij} \in \mathcal{B}$  such that  $\forall x \in \mathbb{R}$ ,  $\forall i \leq p$ ,  $\forall j \leq q$ , we have

$$\lim_{k \rightarrow +\infty} \tau_{s_{m_k}} a_{ij}(x) = \tilde{a}_{ij}(x) \quad \text{exists} \quad \text{and} \quad \lim_{k \rightarrow +\infty} \tau_{-s_{m_k}} \tilde{a}_{ij}(x) = a_{ij}(x), \quad (5.5)$$

and the following limits exist in  $\mathcal{D}'$ ,

$$\lim_{k \rightarrow +\infty} \tau_{s_{m_k}} T_{aa} = \mathcal{V} \quad \text{and} \quad \lim_{k \rightarrow +\infty} \tau_{-s_{m_k}} \mathcal{V} = T_{aa}, \quad (5.6)$$

$$\lim_{k \rightarrow +\infty} \tau_{s_{m_k}} S_{aa} = \mathcal{P} \quad \text{and} \quad \lim_{k \rightarrow +\infty} \tau_{-s_{m_k}} \mathcal{P} = S_{aa},$$

$$\lim_{k \rightarrow +\infty} \tau_{s_{m_k}} T_{cor} = 0 \quad \text{and} \quad \lim_{k \rightarrow +\infty} \tau_{s_{m_k}} S_{cor} = 0. \quad (5.7)$$

Let  $\varphi \in \mathcal{D}$ , we have

$$\begin{aligned} \langle \tau_{s_{m_k}}(L_\omega T), \varphi \rangle &= \sum_{i=0}^p \sum_{j=0}^q (-1)^i \langle T, \tau_{-\omega_j} (a_{ij} \tau_{-s_{m_k}} \varphi)^{(i)} \rangle + \langle K * \tau_{s_{m_k}} T, \varphi \rangle, \\ &= \sum_{i=0}^p \sum_{j=0}^q (-1)^i \langle \tau_{s_{m_k}} T, \tau_{-\omega_j} (\varphi \tau_{s_{m_k}} a_{ij})^{(i)} \rangle + \langle K * \tau_{s_{m_k}} T, \varphi \rangle, \\ &= \sum_{i=0}^p \sum_{j=0}^q \langle \tau_{s_{m_k}} a_{ij} \tau_{\omega_j} (\tau_{s_{m_k}} T)^{(i)}, \varphi \rangle + \langle K * \tau_{s_{m_k}} T, \varphi \rangle, \\ &= \langle L_{\omega, k}(\tau_{s_{m_k}} T), \varphi \rangle, \end{aligned}$$

where

$$L_{\omega, k} = \sum_{i=0}^p \sum_{j=0}^q \tau_{s_{m_k}} a_{ij} \frac{d^i}{dx^i} \tau_{\omega_j} + K * .$$

On  $[-s_{m_k}, +\infty[$  we have  $\tau_{s_{m_k}} S = \tau_{s_{m_k}} L_\omega T$ , i.e.

$$\tau_{s_{m_k}} S_{aa} + \tau_{s_{m_k}} S_{cor} = \tau_{s_{m_k}} (L_\omega T_{aa}) + \tau_{s_{m_k}} (L_\omega T_{cor}) = (L_{\omega, k} \tau_{s_{m_k}} T_{aa}) + (L_{\omega, k} \tau_{s_{m_k}} T_{cor}),$$

By (5.5), (5.6), (5.7) and Lemma 1, the limits

$$\lim_{k \rightarrow +\infty} (\tau_{s_{m_k}} S_{aa} + \tau_{s_{m_k}} S_{cor}) = \lim_{k \rightarrow +\infty} (L_{\omega, k} \tau_{s_{m_k}} T_{aa}) + \lim_{k \rightarrow +\infty} (L_{\omega, k} \tau_{s_{m_k}} T_{cor}),$$

give

$$\mathcal{P} = \tilde{L}_\omega \mathcal{V} \quad \text{on } \mathbb{R},$$

where

$$\tilde{L}_\omega = \sum_{i=0}^p \sum_{j=0}^q \tilde{a}_{ij} \frac{d^i}{dx^i} \tau_{\omega_j} + K * .$$

Consequently by (5.6) we obtain

$$\lim_{k \rightarrow +\infty} \tau_{-s_{m_k}} \mathcal{P} = \lim_{k \rightarrow +\infty} (\tilde{L}_{\omega, k} \tau_{-s_{m_k}} \mathcal{V}) \quad \text{on } \mathbb{R},$$

where

$$\tilde{L}_{\omega, k} = \sum_{i=0}^p \sum_{j=0}^q \tau_{-s_{m_k}} \tilde{a}_{ij} \frac{d^i}{dx^i} \tau_{\omega_j} + K *,$$

which gives

$$S_{aa} = L_\omega T_{aa} \quad \text{on } \mathbb{R}.$$

Finally, the equation  $S_{aa} + S_{cor} = L_\omega T_{aa} + L_\omega T_{cor}$  on  $\mathbb{J}$  implies

$$S_{cor} = L_\omega T_{cor} \quad \text{on } \mathbb{J},$$

hence the conclusion is true.  $\square$

*Remark 8.* The proof of the theorem appeals to Lemma 1 and particularly to Proposition 9 characterising the introduced space of smooth asymptotically almost automorphic functions.

*Remark 9.* The result of the theorem remains valid if we consider systems. Other problems can be tackled within the space of asymptotically almost automorphic distributions.

The following result concerns primitives.

**Corollary 3.** *Let  $S \in \mathcal{B}'_{aaa}$ , the following propositions are equivalent:*

- (1)  $T \in \mathcal{B}'_{aaa}$  is a primitive of  $S$  on  $\mathbb{J}$ .
- (2) There exist  $V \in \mathcal{B}'_{aa}$  a primitive on  $\mathbb{R}$  of  $S_{aa}$  and  $W \in \mathcal{B}'_{+,0}$  a primitive of  $S_{cor}$  on  $\mathbb{J}$  such that

$$T = V + W \quad \text{on } \mathbb{J}.$$

## REFERENCES

1. Bochner S. Uniform convergence of monotone sequences of functions. *Proc. Natl. Acad. Sci. USA*, 1961. Vol. 47, No. 4. P. 582–585. DOI: [10.1073/pnas.47.4.582](https://doi.org/10.1073/pnas.47.4.582)
2. Bochner S. A new approach to almost periodicity. *Proc. Natl. Acad. Sci. USA*, 1962. Vol. 48, No. 12. P. 2039–2043. DOI: [10.1073/pnas.48.12.2039](https://doi.org/10.1073/pnas.48.12.2039)
3. Bochner S. Continuous mappings of almost automorphic and almost periodic functions. *Proc. Natl. Acad. Sci. USA*, 1964. Vol. 52, No. 4. P. 907–910. DOI: [10.1073/pnas.52.4.907](https://doi.org/10.1073/pnas.52.4.907)
4. Bohr H. *Almost Periodic Functions*. Chelsea Publishing Company, 1947. 113 p.
5. Bouzar C., Khalladi M. T., Tchouar F. Z. Almost automorphic generalized functions. *Novi Sad J. Math.*, 2015. Vol. 45, No. 1. P. 207–214. DOI: [10.30755/NSJOM.GF14.01](https://doi.org/10.30755/NSJOM.GF14.01)
6. Bouzar C., Tchouar F. Z. Almost automorphic distributions. *Mediterr. J. Math.*, 2017. Vol. 14. Art. No. 151. DOI: [10.1007/s00009-017-0953-3](https://doi.org/10.1007/s00009-017-0953-3)
7. Cioranescu I. Asymptotically almost periodic distributions. *Appl. Anal.*, 1990. Vol. 34, No. 3–4. P. 251–259. DOI: [/10.1080/00036818908839898](https://doi.org/10.1080/00036818908839898)
8. Levitan B. M., Zhikov V. V. *Almost Periodic Functions and Differential Equations*. Cambridge University Press, 1982. 224 p.
9. Fréchet M. Les fonctions asymptotiquement presque périodiques. *Revue Sci.*, 1941. Vol. 79. P. 341–354.
10. Kostić M. *Asymptotically Almost Periodic and Asymptotically Almost Automorphic Vector Valued Generalized Functions*. 2018. 18 p. [arXiv:1808.03163v1](https://arxiv.org/abs/1808.03163v1) [math.FA]
11. Kostić M., Pilipović S., Velinov D. Quasi-asymptotically almost periodic vector-valued generalized functions. *Sarajevo J. Math.*, 2019. Vol. 15(28), No. 2. P. 181–199.
12. N'Guérékata G. M. Some remarks on asymptotically almost automorphic functions. *Riv. Math. Univ. Parma*, 1987. Vol. 13. P. 301–303.
13. Schwartz L. *Théorie des Distributions*. Paris: Hermann, DL, 1966.
14. Seeley R. T. Extension of  $C^\infty$  functions defined in a half space. *Proc. Amer. Math. Soc.*, 1964. Vol. 15, No. 4. P. 625–626. DOI: [10.1090/S0002-9939-1964-0165392-8](https://doi.org/10.1090/S0002-9939-1964-0165392-8)
15. Sobolev S. L. *Applications of Functional Analysis in Mathematical Physics*. American Mathematical Society, 1963. 239 p.
16. Stepanov V. V. *Sur Quelques Généralisations des Fonctions Presque Périodiques*. Paris: C. R. Acad. Sci., 1925. Vol. 181, P. 90–92.
17. Tchouar F. Z. Asymptotically almost automorphic generalized functions. *Abstr. of the Int. Conf. GF 2016, September 4-9, Dubrovnik*, 2016. P. 67.
18. Zaki M. Almost automorphic solutions of certain abstract differential equations. *Ann. Mat. Pura Appl. (4)*, 1974. Vol. 101. P. 91–114.

# THE LIMITS OF APPLICABILITY OF THE LINEARIZATION METHOD IN CALCULATING SMALL–TIME REACHABLE SETS<sup>1</sup>

Mikhail I. Gusev

Krasovskii Institute of Mathematics and Mechanics,  
Ural Branch of the Russian Academy of Sciences,  
16 S. Kovalevskaya Str., Ekaterinburg, 620990, Russia

[gmi@imm.uran.ru](mailto:gmi@imm.uran.ru)

**Abstract:** The reachable sets of nonlinear systems are usually quite complicated. They, as a rule, are non-convex and arranged to have rather complex behavior. In this paper, the asymptotic behavior of reachable sets of nonlinear control-affine systems on small time intervals is studied. We assume that the initial state of the system is fixed, and the control is bounded in the  $\mathbb{L}_2$ -norm. The subject of the study is the applicability of the linearization method for a sufficiently small length of the time interval. We provide sufficient conditions under which the reachable set of a nonlinear system is convex and asymptotically equal to the reachable set of a linearized system. The concept of asymptotic equality is defined in terms of the Banach-Mazur metric in the space of sets. The conditions depend on the behavior of the controllability Gramian of the linearized system — the smallest eigenvalue of the Gramian should not tend to zero too quickly when the length of the time interval tends to zero. The indicated asymptotic behavior occurs for a reasonably wide class of second-order nonlinear control systems but can be violated for systems of higher dimension. The results of numerical simulation illustrate the theoretical conclusions of the paper.

**Key words:** Nonlinear control systems, Small-time reachable sets, Asymptotics, Integral constraints, Linearization.

## 1. Introduction

The paper explores the properties of reachable sets of control-affine nonlinear systems with integral constraints over small time intervals. The geometric structure of reachable sets plays an important role in control theory, in particular, in solving problems of control synthesis. Small-time reachable sets under pointwise (geometric) constraints on control were studied by C. Lobry, H. Sussmann, A. J. Krener, H. Schattler, and C. I. Byrnes (see, for example, [12, 19]). In general, the reachable sets of nonlinear systems are not convex and may have a quite complicated structure [1, 3, 11, 13–15, 20, 21]. When some of the parameters of a control system are small (initial deviations from the equilibrium position, disturbances at the input of the system, etc.), the behavior of the system can often be judged by the action of its linear approximation. Here we find out under what conditions this linearization approach is applicable when constructing reachable sets on small time intervals. Will these sets be close to reachable sets of a linearized system? In this paper, we study reachable sets for control-affine systems on small time intervals with integral quadratic constraints on the controls. Reachable sets of nonlinear systems with integral constraints were studied in [5–7, 16]. If a system is linear, its reachable set is an ellipsoid in the state space. Therefore, an ellipsoid is the reachable set of a linearized system. To establish the proximity of the reachable sets of original and linearized systems, it is necessary first to find out in which

---

<sup>1</sup>This work is supported by the Research and Education Center of IMM UB of RAS in the framework of the Ural Mathematical Center (project “Set-Valued Dynamics in Control and Estimation Problems for Dynamical Systems with Uncertainty”).



cases the reachable set of the original nonlinear system is convex. B. Polyak [17] proved that a nonlinear image of a small ball in a Hilbert space is convex under some regularity assumptions on the mapping. Using this result, he showed that reachable sets of a nonlinear control system are convex if constraints on the control are given by a ball of a sufficiently small radius in  $\mathbb{L}_2$  and the linearized system is controllable [16]. Using a time change, we reduce the problem of constructing the reachable set of a system on a small time interval to a similar problem on a unit interval. With this replacement, the integral constraints are given by a ball of small radius, and we apply Theorem 1 from [17] to propose sufficient conditions for the convexity of small-time reachable sets. The application of these conditions requires a study of the asymptotic behavior of the controllability Gramian of the linearized system depending on a small parameter.

Another question is how to evaluate the degree of proximity of reachable sets for small lengths of time intervals. These sets contract to a single-point set as the interval length tends to zero, so the Hausdorff metric is not enough for this purpose. Here we use the concept of asymptotic equality of sets introduced in [4] and based on the Banach–Mazur metric.

The paper is arranged as follows. In Section 1, we introduce the concept of asymptotic equality of sets using the Banach–Mazur metric. We prove several auxiliary statements concerning the connection of this concept with the properties of support functions. In Section 2, we consider relations between the images of a Hilbert ball under nonlinear mapping depending on a small parameter and under its linear approximation. Further, we apply these results to the study of the asymptotic behavior of the reachable sets of nonlinear systems with integral control constraints. We formulate sufficient conditions for the asymptotic equality of reachable sets of nonlinear and linearized systems. These conditions depend on the asymptotic behavior of the controllability Gramian of the linearized system. The asymptotic behavior of the smallest eigenvalue of the controllability Gramian for a time-invariant linear control system with a single input is studied in Section 3. In Section 4, we apply the obtained asymptotics to the study of reachable sets for affine-control nonlinear systems on a small time interval. We give two examples of nonlinear two-dimensional systems and present the results of numerical simulations.

## 2. Asymptotic equality of sets

Let  $X, Y \subset \mathbb{R}^n$  be convex compact sets. We assume that the zero vector is an interior point of each of these sets. The Banach–Mazur distance  $\rho(X, Y)$  between  $X$  and  $Y$  is defined by the equality

$$\rho(X, Y) := \log (r(X, Y) \cdot r(Y, X)), \quad r(X, Y) = \inf \{t \geq 1 : tX \supset Y\}.$$

For convex closed sets  $X$  and  $Y$ , the inclusion  $tX \supset Y$  holds if and only if

$$t\delta(y|X) \geq \delta(y|Y), \quad \forall y \in \mathbb{R}^n, \quad \|y\| = 1,$$

where  $\delta(y|X)$  is the support function of the set  $X$ :

$$\delta(y|X) := \sup \{(y, x) : x \in X\}, \quad y \in \mathbb{R}^n.$$

Hence, we have the formula

$$r(X, Y) = \max \left\{ 1, \sup_{\|y\|=1} \frac{\delta(y|X)}{\delta(y|Y)} \right\}. \quad (2.1)$$

Note that, due to the condition  $0 \in \text{int } Y$ , the inequality  $\delta(y|Y) > 0$  holds for  $\|y\| \neq 0$ .

Suppose further that the sets under consideration depend on a small positive parameter  $\varepsilon$ ,  $X = X(\varepsilon)$  and  $Y = Y(\varepsilon)$  are convex compact sets, and the zero vector is an interior point of each

of these sets for  $0 < \varepsilon \leq \varepsilon_0$ . We also assume that the multivalued mappings  $X(\varepsilon)$  and  $Y(\varepsilon)$  are bounded. The sets  $X(\varepsilon)$  and  $Y(\varepsilon)$  are called asymptotically equal [4] if  $\rho(X(\varepsilon), Y(\varepsilon)) \rightarrow 0$  as  $\varepsilon \rightarrow 0$ .

We use the notation

$$\Delta_{XY}(y, \varepsilon) := \frac{\delta(y|X(\varepsilon))}{\delta(y|Y(\varepsilon))}, \quad \Delta_{YX}(y, \varepsilon) := \frac{\delta(y|Y(\varepsilon))}{\delta(y|X(\varepsilon))}.$$

Formula (2.1) implies the following statement.

**Lemma 1.** *In order to  $\rho(X(\varepsilon), Y(\varepsilon)) \rightarrow 0$  as  $\varepsilon \rightarrow 0$ , it is necessary and sufficient that*

$$\lim_{\varepsilon \rightarrow 0} \Delta_{XY}(y, \varepsilon) = 1 \quad \text{uniformly in } y, \quad \|y\| = 1. \quad (2.2)$$

**P r o o f.** It follows from (2.2) that  $\lim_{\varepsilon \rightarrow 0} \sup_{\|y\|=1} \Delta_{XY}(y, \varepsilon) = 1$ . Since  $\Delta_{XY}(y, \varepsilon) \cdot \Delta_{YX}(y, \varepsilon) = 1$ , we have  $\lim_{\varepsilon \rightarrow 0} \sup_{\|y\|=1} \Delta_{YX}(y, \varepsilon) = 1$ . From formula (2.1), we find that  $r(X(\varepsilon), Y(\varepsilon)) \rightarrow 1$  and  $r(Y(\varepsilon), X(\varepsilon)) \rightarrow 1$ ; therefore,  $\rho(X(\varepsilon), Y(\varepsilon)) \rightarrow 0$  as  $\varepsilon \rightarrow 0$ .

To prove the necessity of condition (2.2), suppose, on the contrary, that this condition is violated. Then there exist  $1 > \sigma > 0$  and a sequence  $\varepsilon_k \rightarrow 0$  such that the following relations are valid for an infinite number of the sequence terms:

$$\sup_{\|y\|=1} \Delta_{XY}(y, \varepsilon_k) \geq 1 + \sigma \quad \text{or} \quad \sup_{\|y\|=1} \Delta_{XY}(y, \varepsilon_k) \leq 1 - \sigma.$$

In the former case, we have  $r(X(\varepsilon_k), Y(\varepsilon_k)) \geq 1 + \sigma$  and, therefore,  $\rho(X(\varepsilon_k), Y(\varepsilon_k)) \geq \log(1 + \sigma) > 0$ . In the latter case, we obtain

$$\Delta_{XY}(y, \varepsilon_k) \leq 1 - \sigma, \quad \forall y, \quad \|y\| = 1,$$

and hence

$$\sup_{\|y\|=1} \Delta_{YX}(y, \varepsilon_k) \geq \frac{1}{1 - \sigma}.$$

This implies that

$$\rho(X(\varepsilon_k), Y(\varepsilon_k)) \geq \log \left( 1 + \frac{\sigma}{1 - \sigma} \right) > 0$$

for an infinite number of the sequence terms  $\varepsilon_k$ . This contradicts the convergence of  $\rho(X(\varepsilon_k), Y(\varepsilon_k))$  to zero.  $\square$

The condition  $\rho(X(\varepsilon), Y(\varepsilon)) \rightarrow 0$  implies that  $h(X(\varepsilon), Y(\varepsilon)) \rightarrow 0$  as  $\varepsilon \rightarrow 0$ , where  $h$  denotes the Hausdorff distance between the sets. Indeed, by Lemma 1, relation (2.2) holds in this case. Therefore, for any  $\sigma > 0$ , there exists  $\bar{\varepsilon}$  such that the inequalities

$$\Delta_{XY}(y, \varepsilon) \leq 1 + \sigma, \quad \Delta_{YX}(y, \varepsilon) \leq 1 + \sigma$$

hold for all  $y \in \mathbb{R}^n$ ,  $\|y\| = 1$ ,  $0 < \varepsilon \leq \bar{\varepsilon}$ . These inequalities imply the estimate

$$h(X(\varepsilon), Y(\varepsilon)) = \sup_{\|y\|=1} |\delta(y|X(\varepsilon)) - \delta(y|Y(\varepsilon))| \leq \sigma \max \left\{ \sup_{\|y\|=1} \delta(y|Y(\varepsilon)), \sup_{\|y\|=1} \delta(y|X(\varepsilon)) \right\},$$

which means that  $h(X(\varepsilon), Y(\varepsilon)) \rightarrow 0$  as  $\varepsilon \rightarrow 0$ .

The converse is not true, as the following example shows. Let

$$X(\varepsilon) = \{x \in \mathbb{R}^2 : |x_1| \leq \varepsilon, |x_2| \leq \varepsilon\}, \quad Y(\varepsilon) = \{x \in \mathbb{R}^2 : x_1^2 + x_2^2 \leq \varepsilon^2\}.$$

Then  $h(X(\varepsilon), Y(\varepsilon)) = (\sqrt{2} - 1)\varepsilon \rightarrow 0$  and  $\rho(X(\varepsilon), Y(\varepsilon)) = \log \sqrt{2} > 0$ . Nevertheless, under the additional assumption about the rate of convergence of the Hausdorff distance between the sets, we prove in Theorem 1 that  $\rho(X(\varepsilon), Y(\varepsilon)) \rightarrow 0$  as  $\varepsilon \rightarrow 0$ .

For  $A \subset \mathbb{R}^n$ , define  $\delta_{\min}(A) := \inf_{\|y\|=1} \delta(y|A)$ .

**Theorem 1.** *The following conditions are sufficient for  $\rho(X(\varepsilon), Y(\varepsilon)) \rightarrow 0$  as  $\varepsilon \rightarrow 0$ :*

$$\lim_{\varepsilon \rightarrow 0} h(X(\varepsilon), Y(\varepsilon)) = 0, \quad \lim_{\varepsilon \rightarrow 0} \frac{h(X(\varepsilon), Y(\varepsilon))}{\delta_{\min}(Y(\varepsilon))} = 0.$$

**P r o o f.** Let  $h(\varepsilon) = h(X(\varepsilon), Y(\varepsilon))$  and  $\delta(\varepsilon) = \delta_{\min}(Y(\varepsilon))$ . From the equality

$$h(\varepsilon) = h(X(\varepsilon), Y(\varepsilon)) = \sup_{\|y\|=1} |\delta(y|X(\varepsilon)) - \delta(y|Y(\varepsilon))|,$$

it follows that

$$-h(\varepsilon) \leq \delta(y|X(\varepsilon)) - \delta(y|Y(\varepsilon)) \leq h(\varepsilon)$$

for all  $y \in \mathbb{R}^n$ ,  $\|y\| = 1$ . Dividing these inequalities by a positive value  $\delta(y|Y(\varepsilon))$ , we get

$$\left| \sup_{\|y\|=1} \frac{\delta(y|X(\varepsilon))}{\delta(y|Y(\varepsilon))} - 1 \right| \leq \sup_{\|y\|=1} \frac{h(\varepsilon)}{\delta(y|Y(\varepsilon))} \leq \frac{h(\varepsilon)}{\delta(\varepsilon)}.$$

Dividing these inequalities by  $\delta(y|X(\varepsilon))$  and taking into account that, in view of the conditions of the theorem,  $\delta_{\min}(\varepsilon) - h(\varepsilon) > 0$  for sufficiently small  $\varepsilon$ , we get

$$\left| \sup_{\|y\|=1} \frac{\delta(y|Y(\varepsilon))}{\delta(y|X(\varepsilon))} - 1 \right| \leq \sup_{\|y\|=1} \frac{h(\varepsilon)}{\delta(y|X(\varepsilon))} \leq \frac{h(\varepsilon)}{\delta(\varepsilon) - h(\varepsilon)}.$$

From these inequalities, we obtain relations (2.2) and hence, by Lemma 1,  $\rho(X(\varepsilon), Y(\varepsilon)) \rightarrow 0$  as  $\varepsilon \rightarrow 0$ .  $\square$

Note that the definition of  $\rho(X, Y)$  is symmetrical with respect to the sets  $X$  and  $Y$ . Therefore, in the statement of the theorem,  $\delta_{\min}(Y(\varepsilon))$  can be replaced by  $\delta_{\min}(X(\varepsilon))$ .

### 3. Small-time reachable sets of nonlinear systems

#### 3.1. Auxiliary results

Let  $X$  and  $Y$  be Banach spaces. Denote by  $B_X(a, \mu_0) \subset X$  the ball of radius  $\mu_0$  centered at  $a$ . Consider a mapping  $F_\varepsilon : B_X(a, \mu_0) \rightarrow Y$  depending on a parameter  $\varepsilon$ ,  $0 < \varepsilon < \varepsilon_0$ .

**Assumption 1.** *The mapping  $F_\varepsilon(x)$  has a Fréchet derivative with respect to  $x$ , which satisfies the Lipschitz condition on  $B_X(a, \mu_0)$*

$$\|F'_\varepsilon(x_1) - F'_\varepsilon(x_2)\| \leq L(\varepsilon)\|x_1 - x_2\|, \quad x_1, x_2 \in B_X(a, \mu_0), \quad \varepsilon \in (0, \varepsilon_0], \quad (3.1)$$

where  $L(\varepsilon)$  is a function bounded on  $(0, \varepsilon_0]$ .

Let a function  $\mu(\varepsilon)$  map  $(0, \varepsilon_0]$  to  $(0, \mu_0]$ . Assume that  $\mu(\varepsilon) \rightarrow 0$  as  $\varepsilon \rightarrow 0$ . Denote by  $G_\varepsilon$  the image of the ball  $B_X(a, \mu(\varepsilon))$  under the mapping  $F_\varepsilon$ :

$$G_\varepsilon := \{F_\varepsilon(x) : x \in B_X(a, \mu(\varepsilon))\}.$$

**Theorem 2.** *Suppose that condition (3.1) holds. Then*

$$h((\text{co } G_\varepsilon - F_\varepsilon(a)), \mu(\varepsilon)F'_\varepsilon(a)B_X(0, 1)) \leq L(\varepsilon)\mu^2(\varepsilon),$$

where  $h$  is the Hausdorff distance between sets and  $\text{co } G$  denotes the convex hull of the set  $G$ .

P r o o f. The proof follows from the proof of Theorem 1 in [10].  $\square$

Let  $X$  and  $Y$  be real Hilbert spaces. Suppose that a mapping  $F : X \supset B_X(a, \mu_0) \rightarrow Y$  is differentiable and its Frechét derivative  $F'$  satisfies the Lipschitz condition with constant  $L$ . Let a mapping  $F$  be regular at the point  $a$ , i.e., let the operator  $F'(a) : X \rightarrow Y$  be a surjection. The latter property implies the existence of a positive number  $\gamma$  such that  $\|F'(a)^*y\| \geq \gamma\|y\|$  for all  $y \in Y$ , which is equivalent to the inequality

$$(F'(a)F'(a)^*y, y) \geq \nu\|y\|^2$$

for all  $y \in Y$ , where  $\nu = \gamma^2$  is the smallest eigenvalue of the self-adjoint operator  $F'(a)F'(a)^*$ . Here  $(\cdot, \cdot)$  is the bilinear form for the duality between  $Y$  and the space  $Y^*$  conjugate to  $Y$ ,  $F'(a)^*$  stands for the operator adjoint to a bounded linear operator  $F'(a)$ . In [17, Theorem 1], it is shown that, if the inequality

$$\mu \leq \min \left\{ \mu_0, \frac{\sqrt{\nu}}{2L} \right\} \quad (3.2)$$

holds, then the image of the ball  $B_X(a, \mu)$ , i.e., the set  $G = \{F(x) : x \in B_X(a, \mu)\}$ , is convex.

In what follows, we assume that  $X$  is a Hilbert space and  $Y = \mathbb{R}^n$  is a finite-dimensional Euclidean space. Consider the family of operators  $F_\varepsilon$  assuming that each mapping  $F_\varepsilon$  is regular at the point  $a$ . Denote by  $\nu(\varepsilon)$  the smallest eigenvalue of the operator (matrix)

$$W_\varepsilon := F'_\varepsilon(a)F'_\varepsilon(a)^*.$$

Note that in this case the set  $E_\varepsilon := F'_\varepsilon(a)B_X(0, 1)$  is a finite-dimensional ellipsoid defined by the relation

$$E_\varepsilon = \{x \in \mathbb{R}^n : x^\top W_\varepsilon^{-1}x \leq 1\},$$

and  $\sqrt{\nu(\varepsilon)}$  is the length of its smallest semiaxis. Theorem 2 implies the following statement.

**Corollary 1.** *Suppose that  $\mu(\varepsilon) \leq \sqrt{\nu(\varepsilon)}/(2L(\varepsilon))$ . Then the set  $G_\varepsilon$  is convex and*

$$h(G_\varepsilon, F_\varepsilon(a) + \mu(\varepsilon)E_\varepsilon) \leq L(\varepsilon)\mu^2(\varepsilon).$$

P r o o f. The convexity of  $G_\varepsilon$  follows from inequality (3.2). Hence, under the conditions of the corollary,  $G_\varepsilon = \text{co } G_\varepsilon$ . Using Theorem 2, we get

$$h(G_\varepsilon, F_\varepsilon(a) + \mu(\varepsilon)E_\varepsilon) = h(\text{co } G_\varepsilon - F_\varepsilon(a), \mu(\varepsilon)F'_\varepsilon(a)B_X(0, 1)) \leq L(\varepsilon)\mu^2(\varepsilon).$$

$\square$

**Corollary 2.** *Suppose that  $\mu(\varepsilon)L(\varepsilon)/\sqrt{\nu(\varepsilon)} \rightarrow 0$  as  $\varepsilon \rightarrow 0$ . Then the set  $G_\varepsilon$  is convex for sufficiently small  $\varepsilon$  and*

$$\rho(G_\varepsilon - F_\varepsilon(a), \mu(\varepsilon)E_\varepsilon) \rightarrow 0 \text{ as } \varepsilon \rightarrow 0.$$

P r o o f. Since  $\mu(\varepsilon)L(\varepsilon)/\sqrt{\nu(\varepsilon)} \rightarrow 0$ , we have  $\mu(\varepsilon)L(\varepsilon)/\sqrt{\nu(\varepsilon)} \leq 1/2$  for all sufficiently small  $\varepsilon$ . For these  $\varepsilon$ , we have  $\mu(\varepsilon) \leq \sqrt{\nu(\varepsilon)}/(2L(\varepsilon))$ , hence,  $G_\varepsilon$  is convex. Consider two convex compact sets depending on  $\varepsilon$ :

$$X(\varepsilon) = G_\varepsilon - F_\varepsilon(a), \quad Y(\varepsilon) = \mu(\varepsilon)E_\varepsilon.$$

Calculating the value  $\delta(\varepsilon) = \delta_{\min}(Y(\varepsilon))$  (see Theorem 1), we get

$$\delta(y|Y(\varepsilon)) = \mu(\varepsilon)\sqrt{y^\top W_\varepsilon y}, \quad \delta(\varepsilon) = \min_{\|y\|=1} \delta(y|Y(\varepsilon)) = \mu(\varepsilon)\sqrt{\nu(\varepsilon)}.$$

Since  $\delta(\varepsilon) > 0$  for  $\varepsilon > 0$ , we have  $0 \in \text{int } Y(\varepsilon)$ . It follows from Lyusternik's theorem [2] that  $F_\varepsilon(a) \in \text{int } G_\varepsilon$  for  $\varepsilon > 0$ . Thus, the zero vector is an interior point of  $X(\varepsilon)$  and  $Y(\varepsilon)$  for all sufficiently small positive  $\varepsilon$ .

In view of the inequality  $h(X(\varepsilon), Y(\varepsilon)) \leq L(\varepsilon)\mu(\varepsilon)^2$ , we have

$$\frac{h(X(\varepsilon), Y(\varepsilon))}{\delta(\varepsilon)} \leq \frac{L(\varepsilon)\mu(\varepsilon)^2}{\mu(\varepsilon)\sqrt{\nu(\varepsilon)}} = \frac{\mu(\varepsilon)L(\varepsilon)}{\sqrt{\nu(\varepsilon)}} \rightarrow 0 \text{ as } \varepsilon \rightarrow 0.$$

By Theorem 1, we find that  $\rho(X(\varepsilon), Y(\varepsilon)) \rightarrow 0$ . □

Thereby, the set  $G_\varepsilon - F_\varepsilon(a)$  is asymptotically equal to  $\mu(\varepsilon)E_\varepsilon$ . This means that the image of the ball  $B(a, \mu(\varepsilon))$  under the nonlinear transformation  $F_\varepsilon$  is close in shape to the ellipsoid  $F_\varepsilon(a) + \mu(\varepsilon)E_\varepsilon$ . The latter is the result of transforming the ball by means of a linear approximation of  $F_\varepsilon$  at the point  $a$ .

### 3.2. Small-time reachable sets

Consider a nonlinear control-affine system

$$\dot{x}(t) = f_1(x(t)) + f_2(x(t))u(t), \quad 0 \leq t \leq \varepsilon \leq \bar{\varepsilon}, \quad x(0) = x^0, \quad (3.3)$$

where  $x \in \mathbb{R}^n$  and  $u \in \mathbb{R}^r$  are state and control inputs, respectively, and  $\bar{\varepsilon} > 0$ . The initial state  $x^0$  is assumed to be fixed. Denote by  $\mathbb{L}_2[0, \bar{\varepsilon}]$  the Hilbert space of square integrable functions  $[0, \bar{\varepsilon}] \rightarrow \mathbb{R}^r$ . Constraints on controls are given in the form

$$u(\cdot) \in B(0, \mu),$$

where  $B(0, \mu) := \{u(\cdot) \in \mathbb{L}_2[0, \bar{\varepsilon}] : (u(\cdot), u(\cdot)) \leq \mu^2\}$  is a ball of radius  $\mu > 0$  centered at zero and

$$(u(\cdot), u(\cdot)) = \|u(\cdot)\|_{\mathbb{L}_2[0, \bar{\varepsilon}]}^2 = \int_0^{\bar{\varepsilon}} u^\top(t)u(t)dt.$$

Suppose that, for any  $u(\cdot) \in B(0, \mu)$ , there exists a unique solution  $x(t, u(\cdot))$  of system (3.3), this solution is defined on  $[0, \bar{\varepsilon}]$ , and all trajectories starting from  $x^0$  and corresponding to the controls from the ball  $B(0, \mu)$  belong to a compact set  $D$ . Assume also that the functions  $f_1$  and  $f_2$  have Lipschitz continuous derivatives on  $D$ .

Let  $G(\varepsilon, \mu)$  be the reachable set of system (3.3) at time  $\varepsilon \in [0, \bar{\varepsilon}]$  under integral constraints

$$G(\varepsilon, \mu) := \{x \in \mathbb{R}^n : \exists u(\cdot) \in B(0, \mu), x = x(\varepsilon, u(\cdot))\}.$$

Since  $\|u(\cdot)\|_{\mathbb{L}_2[0, \varepsilon]} \leq \|u(\cdot)\|_{\mathbb{L}_2[0, \bar{\varepsilon}]}$ , the set  $G(\varepsilon, \mu)$  can be written as follows:

$$G(\varepsilon, \mu) = \{x \in \mathbb{R}^n : \exists u(\cdot), \|u(\cdot)\|_{\mathbb{L}_2[0, \varepsilon]} \leq \mu, x = x(\varepsilon, u(\cdot))\}.$$

We study the behavior of reachable sets  $G(\varepsilon, \mu)$  under the assumption that  $\varepsilon$  is a small number. Using a time change, we reduce the problem of describing reachable sets on the time interval  $[0, \varepsilon]$  to a similar problem on the interval  $[0, 1]$  for another system whose equations and integral constraints on the control depend on  $\varepsilon$ .

Representing  $t$  in the form  $t = \varepsilon\tau$ , we set  $y(\tau) = x(\varepsilon\tau)$  and  $v(\tau) = \varepsilon u(\varepsilon\tau)$ . Then

$$\dot{y}(\tau) = \varepsilon f_1(y(\tau)) + f_2(y(\tau))v(\tau), \quad 0 \leq \tau \leq 1, \quad y(0) = x^0, \quad (3.4)$$

with the following constraint on the new control  $v(\cdot)$ :

$$\int_0^1 v^\top(t)v(t)dt \leq (\mu\sqrt{\varepsilon})^2. \quad (3.5)$$

The trajectories of system (3.4), (3.5) belong to the compact set  $D$  if  $\varepsilon \leq \bar{\varepsilon}$ .

Define  $\mu(\varepsilon) := \mu\sqrt{\varepsilon}$ . Let  $\tilde{G}(1, \mu)$  be the reachable set of system (3.4):

$$\tilde{G}(1, \mu) := \{y \in \mathbb{R}^n : \exists v(\cdot) \in B(0, \mu) \subset \mathbb{L}_2[0, 1], y = y(1, v(\cdot))\}.$$

Hereinafter, we use the same notation  $B(0, \mu)$  for balls in the spaces  $\mathbb{L}_2[0, b]$  with different  $b$ . Besides, for simplicity, we omit the time interval in the notation of the space  $\mathbb{L}_2$  if this does not cause misunderstanding.

Define a family of mappings  $F_\varepsilon : \mathbb{L}_2[0, 1] \rightarrow \mathbb{R}^n$  by the equality  $F_\varepsilon(v(\cdot)) = y_\varepsilon(1, v(\cdot))$ , where  $y_\varepsilon(t, v(\cdot))$  is the solution of system (3.4) corresponding to  $v(\cdot)$ . Since  $y(1, v(\cdot)) = x(t_1, u(\cdot))$ , we have the equality

$$\tilde{G}(1, \mu(\varepsilon)) = G(\varepsilon, \mu) = \{F_\varepsilon(v(\cdot)) : v(\cdot) \in B(0, \mu(\varepsilon))\}.$$

The mapping  $F_\varepsilon(v(\cdot))$  is differentiable; its derivative is defined as follows [10]:

$$F'_\varepsilon(v(\cdot))\Delta v(\cdot) = \Delta y(1, \Delta v(\cdot)),$$

where  $\Delta y(\tau)$  is the solution of system (3.4) linearized along the trajectory  $(y(\tau, v(\cdot)), v(\cdot))$

$$\dot{\Delta y}(\tau) = \varepsilon A(\tau)\Delta y(\tau) + B(\tau)\Delta v(\tau), \quad \tau \in [0, 1], \quad \Delta y(0) = 0. \quad (3.6)$$

Here

$$A(\tau) = \frac{\partial f_1}{\partial x}(y(\tau)) + \sum_{i=1}^r \frac{\partial f_2^i}{\partial x}(y(\tau))v_i(\tau), \quad B(\tau) = f_2(y(\tau)).$$

The following statement is true.

**Proposition 1.** [8, 9] *The mapping  $F'_\varepsilon(v(\cdot))$  is Lipschitz continuous on  $B(0, \mu(\varepsilon))$  with the constant  $L(\varepsilon) = L_0 + L_1\varepsilon$  ( $L_0, L_1 \geq 0$ ). If all elements of the matrix  $f_2$  in the equation of the system are independent of the state (i.e.,  $f_2(x) = f_2$  is a constant matrix), then  $L_0 = 0$ .*

We can use Corollary 2 proved above to describe the reachable sets on small time intervals. In this case,  $a = 0 \in \mathbb{L}_2$  is the zero control and the derivative  $F'_\varepsilon(0)$  is defined by equation (3.6) corresponding to system (3.4) linearized along the trajectory  $(y(\tau, 0), 0)$ . Here  $y(\tau, 0)$  is a solution of (3.4) with  $v(\tau) \equiv 0$ ,  $\tau \in [0, 1]$ . In this case,

$$A(\tau) = \frac{\partial f_1}{\partial x}(y(\tau)), \quad B(\tau) = f_2(y(\tau)).$$

Consider a linear control system

$$\dot{z}(\tau) = \varepsilon A(\tau)z(\tau) + B(\tau)u(\tau), \quad \tau \in [0, 1], \quad (3.7)$$

with continuous matrices  $A(\tau)$  and  $B(\tau)$ .

**Definition 1.** *The symmetric matrix  $W_\varepsilon(\tau)$  defined by the equality*

$$W_\varepsilon(\tau) = \int_0^\tau X_\varepsilon(\tau, s)B(s)B^\top(s)X_\varepsilon^\top(\tau, s)ds, \quad (3.8)$$

where  $X_\varepsilon(\tau, s)$  is the fundamental Cauchy matrix of system (3.7) ( $\dot{X}_\varepsilon(\tau, s) = \varepsilon A(\tau)X_\varepsilon(\tau, s)$ ,  $X(s, s) = I$ ) is called the controllability Gramian of the control system (3.7).

Differentiating equality (3.8), it is easy to see that  $W_\varepsilon(t)$  is a solution of the linear differential equation

$$\dot{W}_\varepsilon(\tau) = \varepsilon A(\tau)W_\varepsilon(\tau) + \varepsilon W_\varepsilon(\tau)A^\top(\tau) + B(\tau)B^\top(\tau), \quad W_\varepsilon(0) = 0.$$

The system is completely controllable on the interval  $[0, 1]$  if and only if  $W_\varepsilon(1)$  is positive definite. It is known (see, for example, [14, 16]) that, in this case, the reachable set under the constraint

$$\int_0^1 u^\top(\tau)u(\tau)d\tau \leq \mu^2$$

is an ellipsoid defined as the set of solutions of the inequality  $x^\top W_\varepsilon^{-1}(1)x \leq \mu^2$ .

From the above, we can conclude that the matrix  $W_\varepsilon = F'_\varepsilon(0)F'_\varepsilon(0)^*$  coincides with the controllability Gramian  $W_\varepsilon(1)$  of system (3.6) and the ellipsoid  $\mu(\varepsilon)E_\varepsilon = \hat{G}(\varepsilon, \mu)$  is the reachable set at time 1 of system (3.6) under constraint (3.5). Note that  $F'_\varepsilon(0)$  equals to  $x(\varepsilon, 0)$ . Taking into account that  $\mu(\varepsilon) = \mu\sqrt{\varepsilon}$ , we arrive at the following statement.

**Theorem 3.** *Let  $\nu(\varepsilon)$  be the smallest eigenvalue of the controllability Gramian  $W_\varepsilon^{-1}(1)$  of the linearized system (3.6). Suppose that  $L(\varepsilon)\sqrt{\varepsilon}/\sqrt{\nu(\varepsilon)} \rightarrow 0$  as  $\varepsilon \rightarrow 0$ . Then the reachable set  $G(\varepsilon, \mu)$  is convex for sufficiently small  $\varepsilon$  and*

$$\rho(G(\varepsilon, \mu) - x(\varepsilon, 0), \hat{G}(\varepsilon, \mu)) \rightarrow 0 \text{ as } \varepsilon \rightarrow 0,$$

where  $\hat{G}(\varepsilon, \mu)$  is the reachable set of the linearized system (3.6).

Using the reverse time change, it is easy to show that  $\hat{G}(\varepsilon, \mu)$  is the reachable set at time  $\varepsilon$  for the linearized system (3.3). Thus, Theorem 3 states that, under proper asymptotic behavior of the smallest eigenvalue of the controllability Gramian, the small-time reachable set is asymptotically equal to the reachable set of the linearized system. The asymptotic behavior of the Gramian for the case of linear autonomous systems is studied in the next section.

## 4. Time-invariant systems on a small time interval

### 4.1. Asymptotics of the smallest eigenvalue of the controllability Gramian

Consider a linear time-invariant control system

$$\dot{x}(t) = \varepsilon Ax(t) + Bu(t), \quad t \in [0, 1], \quad (4.1)$$

where  $x \in \mathbb{R}^n$ ,  $u \in \mathbb{R}^r$ , and  $\varepsilon > 0$  is a small parameter. If the pair  $(A, B)$  is completely controllable, then  $(\varepsilon A, B)$  is also controllable for all  $\varepsilon \neq 0$ . In this case, the smallest eigenvalue of the controllability Gramian  $\nu(\varepsilon) = \nu(W_\varepsilon(1))$  is positive for all  $\varepsilon > 0$ . In this section, we study the asymptotic behavior of  $\nu(\varepsilon)$  for small  $\varepsilon$ .

Consider the controllability Gramian  $W_\varepsilon(t)$  of system (4.1). The matrix  $W_\varepsilon(t)$ ,  $t > 0$ , is positive definite for every  $\varepsilon \neq 0$  if and only if the pair  $(A, B)$  is completely controllable. Let us look for  $W_\varepsilon(t)$  as the sum of series in powers of  $\varepsilon$ :

$$W_\varepsilon(t) = V_0(t) + \varepsilon V_1(t) + \varepsilon^2 V_2(t) + \dots, \quad V_k(0) = 0, \quad k = 0, 1, \dots \quad (4.2)$$

Differentiating (4.2) and equating coefficients at equal powers of  $\varepsilon$ , we get

$$\dot{V}_0(t) = BB^\top, \quad \dot{V}_k(t) = AV_{k-1}(t) + V_{k-1}(t)A^\top, \quad k = 1, 2, \dots \quad (4.3)$$

Integrating equations (4.3), we get

$$V_0(t) = tU_0, \quad V_i(t) = \frac{t^{i+1}}{(i+1)!}AU_i, \quad i = 1, 2, \dots,$$

where

$$U_0 = BB^\top, \quad U_i = AU_{i-1} + U_{i-1}A^\top, \quad k = 1, 2, \dots$$

Thus, for  $W_\varepsilon = W_\varepsilon(1)$ , we have

$$W_\varepsilon = \sum_{k=0}^{\infty} \frac{\varepsilon^k}{(k+1)!} U_k. \quad (4.4)$$

In view of the estimate  $\|U_k\| \leq 2\|A\|\|U_{k-1}\| \leq 2^k\|A\|^k\|U_0\|$ , series (4.4) and (4.2) are majorized by the converging series

$$\sum_{k=0}^{\infty} \frac{(2\varepsilon\|A\|)^k}{(k+1)!} \|U_0\|.$$

Here  $\|A\|$  is the spectral matrix norm induced by the Euclidean vector norm. As a result, we find that the matrix  $W_\varepsilon = W_\varepsilon(1)$  is represented as the sum of series (4.4) uniformly convergent on every bounded subset of  $\mathbb{R}$ .

Note that all matrices  $U_k$  in (4.4) are symmetric but not necessarily positive semi-definite. For  $U_0$ , we obviously have  $\nu(U_0) \geq 0$ . If  $\nu(U_0) > 0$ , then there exists  $\alpha > 0$  such that  $\nu(W_\varepsilon) \geq \alpha$  for sufficiently small  $\varepsilon$ . Further, we assume that  $\nu(U_0) = 0$ , hence  $\nu(W_\varepsilon) \rightarrow 0$  as  $\varepsilon \rightarrow 0$ .

**Definition 2.** [18] *A pair  $(A, B)$  is linearly equivalent to a pair  $(A_1, B_1)$  if there exists a nonsingular matrix  $S$  such that  $A_1 = SAS^{-1}$  and  $B_1 = SB$ .*

Linear equivalent pairs generate equations of the same control system in different coordinate systems. A pair  $(A, B)$  is controllable iff  $(A_1, B_1)$  is controllable. The asymptotic behavior of the controllability Gramians of linear equivalent pairs is the same.

**Proposition 2.** [9, Lemma 1] *Let  $(A, B)$  and  $(A_1, B_1)$  be linearly equivalent pairs, and let  $W_\varepsilon$  and  $W_\varepsilon^1$  be the corresponding controllability Gramians. There exist  $\alpha > 0$  and  $\beta > 0$  such that*

$$\alpha\nu(W_\varepsilon) \leq \nu(W_\varepsilon^1) \leq \beta\nu(W_\varepsilon)$$

for all  $\varepsilon$ .

Consider systems with single control. In this case,  $A$  is an  $n \times n$  matrix and  $B$  is an  $n$ -dimensional column-vector.

**Theorem 4.** [9, Theorem 1] *Assume that a system is completely controllable. If  $n = 2$ , then there exist  $\alpha > 0$  and  $\beta > 0$  such that the following inequality holds for all sufficiently small  $\varepsilon > 0$ :*

$$\alpha\varepsilon^2 \leq \nu(W_\varepsilon) \leq \beta\varepsilon^2.$$

If  $n \geq 3$ , then there exists  $\beta > 0$  such that

$$0 < \nu(W_\varepsilon) \leq \beta\varepsilon^{2n-2}$$

for all sufficiently small  $\varepsilon > 0$ .

The proof of this theorem is based on reducing the control system to the Frobenius form.



## 4.2. Small-time reachable sets of time-invariant systems

Consider an autonomous control system with a single input

$$\dot{x}(t) = f(x(t)) + Bu(t), \quad x(0) = x^0, \quad 0 \leq t \leq \varepsilon, \quad (4.5)$$

where  $x \in \mathbb{R}^n$ ,  $u \in \mathbb{R}$ ,  $f : \mathbb{R}^n \rightarrow \mathbb{R}^n$  is a continuously differential mapping,  $B$  is an  $n \times 1$  matrix (a column-vector), and  $x^0$  is a fixed initial state, with control variables subjected to the quadratic integral constraints

$$\int_0^\varepsilon u^2(t) dt \leq \mu^2.$$

Suppose, as above, that there exists a compact set  $D \subset \mathbb{R}^n$  containing all trajectories of system (4.5) and that  $f(x)$  has a Lipschitz continuous derivative on this set.

Denote by  $A(t) = \frac{\partial f}{\partial x}(x(t, 0))$  the matrix of the system linearized along the trajectory  $x(t, 0)$  corresponding to the zero control. Suppose that  $f(x^0) = 0$ . In this case,  $x(t, 0) \equiv 0$  and, hence,

$$A(t) = \frac{\partial f}{\partial x}(x(t, 0)) = \frac{\partial f}{\partial x}(x^0) = A$$

is a constant matrix. Let  $W_\varepsilon$  be the controllability Gramian of the pair  $(\varepsilon A, B)$  on the interval  $[0, 1]$ , and let  $\nu(\varepsilon)$  be the smallest eigenvalue of  $W_\varepsilon$ . If the pair  $(A, B)$  is controllable, then, by Theorem 4,  $\nu(\varepsilon) \geq \alpha\varepsilon^2$  if  $n = 2$  and  $\nu(W_\varepsilon) \leq \beta\varepsilon^4$  if  $n \geq 3$  for some  $\alpha, \beta > 0$ .

From Theorem 3 we obtain the following statement.

**Corollary 3.** *Let  $n = 2$ , and let system (4.5) linearized at the point  $x^0$  be completely controllable. Then the reachable set  $G(\varepsilon, \mu)$  is convex for all sufficiently small  $\varepsilon$  and asymptotically equal to the reachable set of the linearized system.*

*Proof.* In the conditions of the theorem, we have  $L(\varepsilon) = L_1\varepsilon$  (see Proposition 1) and  $\nu(\varepsilon) \geq \alpha\varepsilon^2$ . This implies that  $L(\varepsilon)\sqrt{\varepsilon}/\sqrt{\nu(\varepsilon)} \leq (L_1/\sqrt{\alpha})\sqrt{\varepsilon} \rightarrow 0$  as  $\varepsilon \rightarrow 0$ .  $\square$

Note that the sufficient conditions for the convexity of  $G(\varepsilon)$  are not satisfied for a system with a single input for  $n \geq 3$ .

## 4.3. Examples

As an illustrative example, consider the Duffing oscillator

$$\dot{x}_1 = x_2, \quad \dot{x}_2 = -x_1 - 10x_1^3 + u, \quad 0 \leq t \leq \varepsilon \quad (4.6)$$

which describes the motion of a nonlinear stiff spring on impact of an external force  $u$ , with integral constraints

$$\int_0^\varepsilon u^2(t) dt \leq \mu^2$$

and zero initial state  $x_1(0) = 0$ ,  $x_2(0) = 0$ .

Consider the Lyapunov-type function

$$V(x) = V(x_1, x_2) = \frac{5}{2}x_1^4 + \frac{1}{2}x_1^2 + \frac{1}{2}x_2^2.$$

Differentiating  $V(x(t))$  along an arbitrary trajectory of the system and applying an analog of Gronwall's Lemma [23], we find that all trajectories of system (4.6) belong to the compact set  $D = \{x \in \mathbb{R}^2 : V(x) \leq \mu^2\varepsilon\}$  (see [22]).

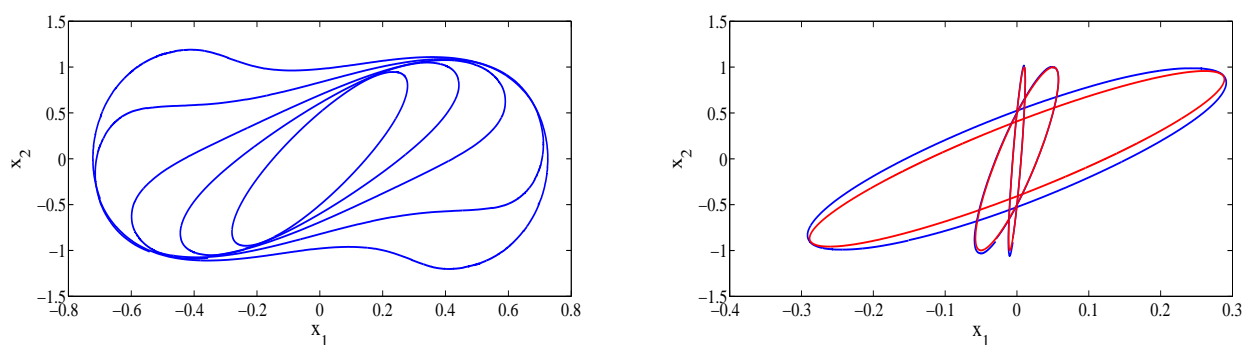

Figure 1. Reachable sets of Duffing oscillator

System (4.6) linearized along  $x(t) \equiv 0$  after a time change

$$\dot{x}_1 = \varepsilon x_2, \quad \dot{x}_2 = -x_1 + u, \quad x(0) = (0, 0), \quad 0 \leq \tau \leq 1,$$

is completely controllable. From Corollary 3 it follows that, for small  $\varepsilon$ , the reachable sets  $G(\varepsilon)$  in this example are convex sets close in shape to ellipsoids.

The results of the numerical simulation are shown in the figure that follows. These results are obtained with the use of an algorithm based on Pontryagin's maximum principle for boundary trajectories.

Fig. 1 shows the results of numerical simulation for this example. Its left-hand side exhibits the plot of the boundaries of the reachable set at times  $\varepsilon = 0.5, 0.7, 0.9, 1.2$ , and  $1.5$ , respectively. A larger set in the figure corresponds to a larger value of  $\varepsilon$ . This plot indicates that the reachable sets for smaller values of  $\varepsilon$  are convex and look like ellipsoids. The right-hand side of the figure corresponds to smaller  $\varepsilon$ . Here the boundaries of reachable sets of the nonlinear system are shown in blue and of the linearized system in red. Note that the reachable sets contract to zero as  $\varepsilon \rightarrow 0$ . In order to make the picture more informative, we multiply each of the sets by a scaling factor  $s(\varepsilon)$  depending on  $\varepsilon$ . The resulting ellipsoids tend to a degenerate ellipsoid (vertical segment) as  $\varepsilon \rightarrow 0$ .

As another example, consider a bilinear system

$$\begin{cases} \dot{x}_1 = x_2 u_1 - x_1 u_2, \\ \dot{x}_2 = -x_1 u_1 - x_2 u_2, \end{cases}$$

with initial state given by the equalities  $x_1(0) = 1$  and  $x_2(0) = 0$ . It is known that, under control constraints in the form

$$|u_1(t)| \leq 1, \quad |u_2(t)| \leq 1, \quad 0 \leq t \leq \varepsilon,$$

the reachable set  $G(\varepsilon)$  is non-convex for any  $\varepsilon > 0$  [18]. Consider further the integral constraints on the control

$$\int_0^\varepsilon (u_1^2(t) + u_2^2(t)) dt \leq 1.$$

All trajectories of the system belong to a compact set on the plane. This fact could be easily proved by using the transition to the polar coordinates. The matrices  $A$  and  $B$  of the system linearized along the trajectory  $x(t) \equiv (1, 0)$  have the following form:

$$A = \begin{pmatrix} 0 & 0 \\ 0 & 0 \end{pmatrix}, \quad B = \begin{pmatrix} 0 & -1 \\ -1 & 0 \end{pmatrix}.$$

The system is completely controllable and the controllability Gramian  $W_\varepsilon$  is independent of  $\varepsilon$ :

$$W_\varepsilon = BB^\top = \begin{pmatrix} 1 & 0 \\ 0 & 1 \end{pmatrix}.$$

Since  $\nu(W_\varepsilon) = \nu(\varepsilon)$  and the Lipschitz constant  $L(\varepsilon)$  is independent of  $\varepsilon$ , we have

$$L(\varepsilon)\sqrt{\varepsilon}/\sqrt{\nu(\varepsilon)} \rightarrow 0$$

as  $\varepsilon \rightarrow 0$ . Consequently, the reachable sets  $G(\varepsilon)$  are convex for sufficiently small  $\varepsilon$  and asymptotically equal to ellipsoids (see also [10]).

## REFERENCES

1. Baier R., Gerdt M., Xausa I. Approximation of reachable sets using optimal control algorithms. *Numer. Algebra Control Optim.*, 2013. Vol. 3, No. 3. P. 519–548. DOI: [10.3934/naco.2013.3.519](https://doi.org/10.3934/naco.2013.3.519)
2. Dmitruk A. V., Milyutin A. A., Osmolovskii N. P. Lyusternik's theorem and the theory of extrema. *Russian Math. Surveys*, 1980. Vol. 35, No. 6. P. 11–51. DOI: [10.1070/RM1980v035n06ABEH001973](https://doi.org/10.1070/RM1980v035n06ABEH001973)
3. Filippova T. F. Ellipsoidal estimates of reachable sets for control systems with nonlinear terms. *IFAC-PapersOnLine*, 2017. Vol. 50, No. 1. P. 15355–15360. DOI: [10.1016/j.ifacol.2017.08.2460](https://doi.org/10.1016/j.ifacol.2017.08.2460)
4. Goncharova E., Ovseevich A. Small-time reachable sets of linear systems with integral control constraints: birth of the shape of a reachable set. *J. Optim. Theory Appl.*, 2016. Vol. 168. P. 615–624. DOI: [10.1007/s10957-015-0754-4](https://doi.org/10.1007/s10957-015-0754-4)
5. Guseinov K. G., Ozer O., Akyar E., Ushakov V. N. The approximation of reachable sets of control systems with integral constraint on controls. *Nonlinear Differ. Equ. Appl.*, 2007. Vol. 14. P. 57–73. DOI: [10.1007/s00030-006-4036-6](https://doi.org/10.1007/s00030-006-4036-6)
6. Guseinov Kh. G., Nazlipinar A. S. Attainable sets of the control system with limited resources. *Trudy Inst. Mat. i Mekh. UrO RAN*, 2010. Vol. 16, No. 5. P. 261–268.
7. Gusev M. On reachability analysis of nonlinear systems with joint integral constraints. In: *Lecture Notes in Comput. Sci., vol. 10665: Large-Scale Scientific Computing. LSSC 2017. Lirkov I., Margenov S. (eds.)* Cham: Springer, 2018. P. 219–227. DOI: [10.1007/978-3-319-73441-5\\_23](https://doi.org/10.1007/978-3-319-73441-5_23)
8. Gusev M. I., Zykov I. V. On extremal properties of the boundary points of reachable sets for control systems with integral constraints. *Proc. Steklov Inst. Math.*, 2018. Vol. 300. Suppl. 1. P. 114–125. DOI: [10.1134/S0081543818020116](https://doi.org/10.1134/S0081543818020116)
9. Gusev M. I. Estimates of the minimal eigenvalue of the controllability Gramian for a system containing a small parameter. In: *Lecture Notes in Comput. Sci., vol. 11548: Int. Conf. Mathematical Optimization Theory and Operations Research. MOTOR 2019. Khachay M., Kochetov Y., Pardalos P. (eds.)* Cham: Springer, 2019. P. 461–473. DOI: [10.1007/978-3-030-22629-9\\_32](https://doi.org/10.1007/978-3-030-22629-9_32)
10. Gusev M. I., Osipov I. O. Asimptoticheskoye povedeniye mnozhestv dostizhimosti na malykh vremennykh promezhutkakh [Asymptotic behavior of reachable sets on small time intervals]. *Trudy Inst. Mat. Mekh. UrO RAN*, 2019. Vol. 25, No. 3. P. 86–99. DOI: [10.21538/0134-4889-2019-25-3-86-99](https://doi.org/10.21538/0134-4889-2019-25-3-86-99) (in Russian)
11. Kostousova E. K. On polyhedral estimates for reachable sets of discrete-time systems with bilinear uncertainty. *Autom. Remote Control*, 2011. Vol. 72. P. 1841–1851. DOI: [10.1134/S0005117911090062](https://doi.org/10.1134/S0005117911090062)
12. Krener A. J., Schättler H. The structure of small-time reachable sets in low dimensions. *SIAM J. Control Optim.*, 1989. Vol. 27. No. 1. P. 120–147. DOI: [10.1137/0327008](https://doi.org/10.1137/0327008)
13. Kurzhanski A. B., Varaiya P. Dynamic optimization for reachability problems. *J. Optim. Theory Appl.*, 2001. Vol. 108(2). P. 227–251. DOI: [10.1023/A:1026497115405](https://doi.org/10.1023/A:1026497115405)
14. Kurzhanski A. B., Varaiya P. *Dynamics and Control of Trajectory Tubes. Theory and Computation.* Systems Control Found. Appl., vol. 85. Basel: Birkhäuser, 2014. 445 p. DOI: [10.1007/978-3-319-10277-1](https://doi.org/10.1007/978-3-319-10277-1)
15. Patsko V. S., Pyatko S. G., Fedotov A. A. Three-dimensional reachability set for a nonlinear control system. *J. Comput. Syst. Sci. Int.*, 2003. Vol. 42. No. 3. P. 320–328.
16. Polyak B. T. Convexity of the reachable set of nonlinear systems under  $L_2$  bounded controls. *Dyn. Contin. Discrete Impuls. Syst. Ser. A Math. Anal.*, 2004. Vol. 11. P. 255–267.
17. Polyak B. T. Local programming. *Comput. Math. Math. Phys.*, 2001. Vol. 41, No. 9. P. 1259–1266.

- 
18. Lee E. B. and Marcus L. *Foundations of Optimal Control Theory*. New York: J. Willey and Sons Inc., 1967. 576 p.
  19. Schättler H. Small-time reachable sets and time-optimal feedback control. In: *Nonsmooth Analysis and Geometric Methods in Deterministic Optimal Control. Vol. 78: The IMA Volumes in Mathematics and its Applications*. Mordukhovich B.S., Sussmann H.J. (eds.) New York: Springer, 1996. P. 203–225. DOI: [10.1007/978-1-4613-8489-2\\_9](https://doi.org/10.1007/978-1-4613-8489-2_9)
  20. Tochilin P. A. On the construction of nonconvex approximations to reach sets of piecewise linear systems. *Differ. Equ.*, 2015. Vol. 51, No. 11. P. 1499–1511. DOI: [10.1134/S0012266115110117](https://doi.org/10.1134/S0012266115110117)
  21. Vdovin S. A., Taras'yev A. M., Ushakov V. N. Construction of the attainability set of a Brockett integrator. *J. Appl. Math. Mech.*, 2004. Vol. 68, No. 5. P. 631–646. DOI: [10.1016/j.jappmathmech.2004.09.001](https://doi.org/10.1016/j.jappmathmech.2004.09.001)
  22. Zykov I. V. On external estimates of reachable sets of control systems with integral constraints. *Izv. IMI UdGU*, 2019. Vol. 53. P. 61–72. DOI: [10.20537/2226-3594-2019-53-06](https://doi.org/10.20537/2226-3594-2019-53-06) (in Russian)
  23. Walter W. *Differential and Integral Inequalities*. Berlin, Heidelberg: Springer-Verlag, 1970. 354 p. DOI: [10.1007/978-3-642-86405-6](https://doi.org/10.1007/978-3-642-86405-6)

# OPTIMAL CONTROL FOR A CONTROLLED ILL-POSED WAVE EQUATION WITHOUT REQUIRING THE SLATER HYPOTHESIS<sup>1</sup>

Abdelhak Hafdallah

Laboratory of Mathematics, Informatics and Systems, University of Larbi Tébessi,  
Rue de Constantine 12002, Tébessa, Algeria  
[abdelhak.hafdallah@univ-tebessa.dz](mailto:abdelhak.hafdallah@univ-tebessa.dz)

**Abstract:** In this paper, we investigate the problem of optimal control for an ill-posed wave equation without using the extra hypothesis of Slater i.e. the set of admissible controls has a non-empty interior. Firstly, by a controllability approach, we make the ill-posed wave equation a well-posed equation with some incomplete data initial condition. The missing data requires us to use the no-regret control notion introduced by Lions to control distributed systems with incomplete data. After approximating the no-regret control by a low-regret control sequence, we characterize the optimal control by a singular optimality system.

**Keywords:** Ill-posed wave equation, No-regret control, Incomplete data, Carleman estimates, Null-controllability.

## 1. Introduction

The first systematic study of optimal control of ill-posed problems was by J.L. Lions in his book “Control of distributed singular systems” [11], exactly when he focused on an ill-posed heat equation (backward heat equation). In his study, he required the set of admissible controls  $U_{ad}$  to have a non-empty interior. This condition is the so-called Slater hypothesis. Regrettably, a difficulty starts when we need to use some sets like the positive cone  $(L^2)^+$ , which has an empty interior, as a set of admissible controls, where the hypothesis of Slater doesn’t hold. To avoid such kind of obstacle, we propose to take a different approach to the regularization approach proposed in [3] and [5], to get an optimality system characterizing the optimal control without requiring Slater extra-hypothesis, it’s the controllability approach.

The aim of our work is to generalize existing results [3, 5] where we seek to get an optimality system characterizing the optimal control for an ill-posed wave equation [4, 5], to reach our goal, we start by assuming that when taking the control in some dense space of  $L^2(Q)$ , the problem becomes well-posed. Then, by null-controllability of the well-posed wave equation, we seek to retrieve the second order time condition in the ill-posed equation. Hence, we get an optimal control problem for a controlled wave equation with incomplete data where we apply the no-regret control method introduced by Lions [12] (the original idea was introduced by Savage in [15]) for optimal control problems with incomplete data.

On the contrary of [5], this work leads us to characterize the optimal control by an optimality system which has a simpler form than the one given in [5], this will be very beneficial in a numerical analysis viewpoint.

---

<sup>1</sup>This work was supported by the Directorate-General for Scientific Research and Technological Development (DGRSDT).

A few studies have been published in the context of optimal control of PDEs with missing data after that by Lions himself [13].

Later, many papers are published such as [14] and [9] where authors studied an age-structured population dynamics of incomplete data. In [1], authors applied the notion of no-regret control on a fractional wave equation with incomplete data. Afterward, a control coupled systems and a wave equation both with incomplete data were treated in [6] and [7] respectively, extended recently to more general and abstract systems in [8].

Actually, the method of no-regret control consists of taking only controls  $v$  such that

$$J(v, g) \leq J(0, g),$$

( $J$  is the cost function) for every missing data  $g$ , where we guarantee the belonging of the optimal control to this set of controls. To avoid the difficulty of characterizing the no-regret control, we should relax the definition by making a quadratic perturbation in no-regret control definition, i.e.

$$J(v, g) \leq J(0, g) + \gamma \|g\|^2, \quad \gamma > 0.$$

In this way, we define a sequence of low-regret controls expected to be converging to the no-regret control.

The recent paper is organized as follows: in the next section we present some preliminaries for the main problem, in the third section we prove existence and uniqueness for the controllability problem, in the fourth we introduce the optimal control problem with missing data, in the fifth, we give an optimality system for the optimal control problem, and we finish with a conclusion.

## 2. Preliminaries

Let  $\Omega \subset \mathbb{R}^N$  be an open bounded domain with smooth boundary  $\Gamma$ ,  $\Gamma_0$  is a non-empty subset of  $\Gamma$ , denote  $Q = \Omega \times (0, T)$ ,  $\Sigma = \Gamma \times (0, T)$ ,  $\Sigma_0 = \Gamma_0 \times (0, T)$  and  $T > 0$ . Consider the following wave equation given by:

$$\begin{cases} y'' - \Delta y = v & \text{in } Q, \\ y(x, 0) = 0, \quad y(x, T) = 0 & \text{in } \Omega, \\ y(x, t) = 0 & \text{on } \Sigma, \end{cases} \quad (2.1)$$

where  $v$  is a distributed control in

$$U_{ad}^\rho = \{v \in L_\rho^2(Q) : v \geq 0 \text{ almost everywhere in } Q\},$$

it's the closed convex cone  $(L_\rho^2(Q))^+$ , where

$$L_\rho^2(Q) = \{w \in L^2(Q) \text{ such that } \rho w \in L^2(Q)\}$$

and  $\rho$  is a positive function defined on  $Q$  such that  $1/\rho$  is bounded in  $Q$ . It's well known that (2.1) is ill-posed [5].

On the other hand, let's consider a null controllability problem for the following wave equation:

$$\begin{cases} y'' - \Delta y = v & \text{in } Q, \\ y(x, 0) = 0, \quad y'(x, 0) = g & \text{in } \Omega, \\ y(x, t) = \begin{cases} \theta & \text{on } \Sigma_0, \\ 0 & \text{on } \Sigma \setminus \Sigma_0, \end{cases} \end{cases} \quad (2.2)$$

where  $g \in L^2(\Omega)$  is a missing initial condition.

The following geometric and time conditions hold:

$$\exists x_0 \notin \bar{\Omega} \text{ such that } \{x \in \partial\Omega : (x - x_0) \cdot \nu(x) \geq 0\} \subset \Gamma_0, \quad (2.3)$$

$$T > 2 \sup_{x \in \Omega} |x - x_0|, \quad (2.4)$$

and  $\nu(x)$  denotes the external unit normal vector at  $x$ .

Note that for every  $(v, g; \theta) \in U_{ad}^\rho \times L^2(\Omega) \times L^2(\Sigma_0)$ , the system (2.2)–(2.4) has a unique solution  $y(v, g; \theta) = y(v, g; \theta)(x, t)$  in some sense (see [10, Ch. 4, p. 325]).

Actually, we want to find a function  $\theta \in L^2(\Gamma_0 \times (0, T))$  such that for every  $v \in U_{ad}^\rho$  and every missing initial condition  $g \in L^2(\Omega)$  the solution of (2.2) verifies the following null controllability property

$$y(x, T) = y'(x, T) = 0. \quad (2.5)$$

In this way, by the controllability of (2.2) we retrieve the initial condition  $y'(x, 0)$  in (2.1) but with an unknown value and (2.1) becomes a well-posed equation with missing data.

After this, we want to find a control function  $v$  in  $U_{ad}^\rho$  solution to the following optimal control problem

$$\inf_{v \in U_{ad}^\rho} J_\rho(v, g) \quad \text{such that} \quad J_\rho(v, g) = \|y(v, g) - y_d\|_\rho^2 + N \|v\|_\rho^2, \quad (2.6)$$

where  $y_d$  is a target function in  $L^2(Q)$ ,  $N > 0$  all are given.

Now, let's prove the existence of a solution for the null-controllability problem (2.2)–(2.5).

### 3. Existence for the null-controllability problem (2.2)–(2.5)

Before treating the controllability problem (2.2)–(2.5) we announce the following theorem giving a so-called Carleman inequality type, which will be the main tool to solve the controllability problem.

**Theorem 1.** *Denote the operator  $L = \partial^2/\partial t^2 - \Delta$  in distribution sense, under the geometric and time conditions (2.3)–(2.4) there exists a  $C^2$  weighted positive function  $\rho$  defined on  $Q$  such that  $1/\rho$  is bounded in  $Q$  and  $C = C(\Omega, T, \Gamma_0, \rho) > 0$  such that:*

$$\int_0^T \int_\Omega \frac{1}{\rho^2} |q|^2 dxdt \leq C \left[ \int_0^T \int_\Omega \frac{1}{\rho^2} |Lq|^2 dxdt + \int_0^T \int_{\Gamma_0} \frac{1}{\rho^2} \left| \frac{\partial q}{\partial \nu} \right|^2 d\Gamma dt \right] \quad (3.1)$$

for every

$$q \in \mathcal{V} = \left\{ \varphi \in L^2(0, T; H_0^1(\Omega)) : L\varphi \in L^2(Q), \frac{\partial \varphi}{\partial \nu} \Big|_{\Sigma_0} \in L^2(\Sigma_0) \right\},$$

where

$$L^2(0, T; H_0^1(\Omega)) = \left\{ \varphi : [0, T] \rightarrow H_0^1(\Omega) \text{ measurable such that } \int_0^T \|\varphi(t)\|_{H_0^1(\Omega)}^2 dt < \infty \right\}.$$

*P r o o f.* It leads from a Carleman inequality, it can be found in [2, Theorem 1.1].

The inequality (3.1) allows us to introduce the following real inner product:

$$a(r, s) = \int_0^T \int_\Omega \frac{1}{\rho^2} Lr \cdot Ls dxdt + \int_0^T \int_{\Gamma_0} \frac{1}{\rho^2} \frac{\partial r}{\partial \nu} \frac{\partial s}{\partial \nu} d\Gamma dt \quad (3.2)$$

on  $V$  the Hilbert space completion of  $\mathcal{V}$ , with its associated norm  $\|\cdot\|_a = \sqrt{a(\cdot, \cdot)}$ .  $\square$

*Remark 1.* We can characterize the structure of  $\mathcal{V}$  as a subspace of a weighted Sobolev space. Indeed, let  $H_\rho(Q)$  be the weighted Hilbert space defined by

$$H_\rho(Q) = \left\{ v \in L^2(Q) \text{ such that: } \int_0^T \int_\Omega \frac{1}{\rho^2} |v|^2 dxdt < \infty \right\},$$

endowed with the natural norm

$$\|\cdot\|_{H_\rho(Q)} = \left( \int_0^T \int_\Omega \frac{1}{\rho^2} |\cdot|^2 dxdt \right)^{1/2}.$$

This shows that  $V$  is embedded continuously in  $H_\rho(Q)$  as:

$$\exists C > 0 : \|v\|_{H_\rho(Q)} \leq C \|v\|_a \quad \text{for every } v \in V.$$

By the boundedness of  $1/\rho^2$  on  $Q$ , we also see that  $L^2(Q)$  is continuously embedded in  $H_\rho(Q)$ .

**Proposition 1.** Fix  $(v, g) \in U_{ad}^\rho \times L^2(\Omega)$ . Define on  $V$  the linear form

$$l_{(v,g)}(s) = \int_0^T \int_\Omega v s dxdt + \int_\Omega g s(0) dx,$$

then there exists a unique solution  $\tilde{p}(v, g) \in V$  to the following variational equation:

$$a(r, s) = l_{(v,g)}(s), \quad \forall s \in V. \quad (3.3)$$

Also, we have

$$\exists C > 0 : \|\tilde{p}(v, g)\|_a \leq C \left( \|v\rho\|_{L^2(Q)} + \|g\|_{L^2(\Omega)} \right). \quad (3.4)$$

Moreover, if we choose

$$y(v, g) = \frac{1}{\rho^2} L\tilde{p}(v, g), \quad \theta(v, g) = \frac{1}{\rho^2} \frac{\partial \tilde{p}(v, g)}{\partial \nu} \Big|_{\Sigma_0}, \quad (3.5)$$

the pair  $\{y(v, g), \theta(v, g)\}$  is a solution of the null controllability problem (2.2)–(2.5).

*P r o o f.* The result is obtained by application of the Lax–Milgram theorem with using Carleman inequality (3.1) to prove that the inner product (3.2) is coercive. Using (3.3) and integration by parts we get the null controllability property (2.5).  $\square$

#### 4. Optimal control of the controlled wave equation with incomplete data

In this principal section, we focus on the following controlled wave equation missing initial condition

$$\begin{cases} y'' - \Delta y = v & \text{in } Q, \\ y(x, 0) = 0, \quad y'(x, 0) = g & \text{in } \Omega, \\ y = \begin{cases} \theta(v, g) & \text{on } \Sigma_0, \\ 0 & \text{on } \Sigma \setminus \Sigma_0, \end{cases} \end{cases} \quad (4.1)$$

with

$$y(x, T) = 0, \quad y'(x, T) = 0, \quad (4.2)$$

where  $\theta(v, g)$  is given by (3.5).



We solve the optimal control problem (4.1), (4.2), (2.6) regardless of the values of the missing initial condition  $g$ , where  $L^2_\rho(Q)$  endowed with the inner product  $(\cdot, \cdot)_\rho = (\rho \cdot, \rho \cdot)_{L^2(Q)}$  and the associated norm  $\|\cdot\|_\rho = \sqrt{(\cdot, \cdot)_\rho}$ .

In order to ensure the existence of the optimal control for (4.1), (4.2), (2.6) we need an extra hypothesis of Slater (see [11, Ch. 4, Remark 1.4]) which requires that

$$U_{ad}^\rho \text{ has a non-empty interior.} \quad (4.3)$$

Unfortunately, the extra hypothesis (4.3) is not fulfilled by  $U_{ad}^\rho$  because it's well known that  $(L^2(Q))^+$  has an empty interior.

However, we propose an approach where there is no need to (4.3), it's the method of *no-regret control* which was introduced by J.L. Lions in [12], to solve optimal control problems with some incomplete data.

First of all, let's give a definition of the no-regret control for the controlled system with missing data (4.1), (4.2), (2.6).

**Definition 1** [12]. *We say that  $u \in U_{ad}^\rho$  is a no-regret control for (4.1), (4.2), (2.6) if  $u$  is the solution of:*

$$\inf_{v \in U_{ad}^\rho} \left( \sup_{g \in L^2(\Omega)} (J_\rho(v, g) - J_\rho(0, g)) \right). \quad (4.4)$$

In the following lemma, we try to rewrite the main quantity in the last definition to isolate the missing data in some way.

**Lemma 1.** *Let  $M$  be an operator defined from  $L^2(\Omega)$  to  $L^2(\Sigma_0)$  by  $Mg = \frac{\partial \tilde{p}}{\partial \nu}(0, g)$ , where  $\tilde{p}(v, g)$  is the unique solution to (3.3). Then,  $M$  is a linear bounded operator on  $L^2(\Omega)$ , and we have*

$$J_\rho(v, g) - J_\rho(0, g) = J_\rho(v, 0) - J_\rho(0, 0) + 2(S(v), g)_{L^2(\Omega)}, \quad (4.5)$$

where  $S$  is also a linear bounded operator from  $U_{ad}^\rho$  to  $L^2(\Omega)$  given by

$$S(v) = \tilde{p}(v, 0)(0) - M^*(\theta(v, 0)).$$

**P r o o f.** It's clear that  $M$  is linear, also  $M$  is bounded. In fact, we know that  $\tilde{p}(v, 0)$  solves (3.3) for every  $s \in V$ , we choose an  $s$  such that

$$\begin{cases} Ls = 0 & \text{in } Q, \\ s(x, 0) = g, \quad s'(x, 0) = 0 & \text{in } \Omega, \\ \frac{\partial s}{\partial \nu} = \begin{cases} \frac{\partial \tilde{p}(0, g)}{\partial \nu} & \text{on } \Sigma_0, \\ 0 & \text{on } \Sigma \setminus \Sigma_0 \end{cases} \end{cases}$$

to get

$$\inf_{\Sigma_0} \frac{1}{\rho^2} \int_0^T \int_{\Gamma_0} \left| \frac{\partial \tilde{p}(0, g)}{\partial \nu} \right|^2 d\Gamma dt \leq \int_0^T \int_{\Gamma_0} \frac{1}{\rho^2} \left| \frac{\partial \tilde{p}(0, g)}{\partial \nu} \right|^2 d\Gamma dt = \|g\|_{L^2(\Omega)}^2.$$

From linearity in (3.3), we get  $y(v, g) = y(v, 0) + y(0, g) + y(0, 0)$ , and by a simple calculation we get

$$J_\rho(v, g) - J_\rho(0, g) = J_\rho(v, 0) - J_\rho(0, 0) + 2(y(v, 0), y(0, g))_\rho.$$

Use Green formula to prove

$$\begin{aligned}
& (y(v, 0), y(0, g))_\rho = (L\tilde{p}(v, 0), y(0, g))_{L^2(Q)} \\
& = (\tilde{p}(v, 0), Ly(0, g))_{L^2(Q)} - \left( \frac{\partial \tilde{p}(v, 0)}{\partial \nu}, \theta(0, g) \right)_{L^2(\Sigma_0)} + (g, \tilde{p}(v, 0)(0))_{L^2(\Omega)} \\
& = (\tilde{p}(v, 0)(0), g)_{L^2(\Omega)} - \left( \frac{\partial \tilde{p}(v, 0)}{\partial \nu}, \frac{1}{\rho^2} \frac{\partial \tilde{p}}{\partial \nu}(0, g) \right)_{L^2(\Sigma_0)} \\
& = (\tilde{p}(v, 0)(0), g)_{L^2(\Omega)} - (M^*(\theta(v, 0)), g)_{L^2(\Omega)}.
\end{aligned}$$

We know that  $\theta(v, 0) : U_{ad}^\rho \rightarrow L^2(\Sigma_0)$  solves (3.4), choose  $s = \tilde{p}(v, 0)$  and use (4.2) to find

$$\begin{aligned}
\inf_{\Sigma_0} \frac{1}{\rho^2} \int_0^T \int_{\Gamma_0} \left| \frac{\partial \tilde{p}(v, 0)}{\partial \nu} \right|^2 d\Gamma dt & \leq \int_0^T \int_{\Gamma_0} \frac{1}{\rho^2} \left| \frac{\partial \tilde{p}(v, 0)}{\partial \nu} \right|^2 d\Gamma dt \leq \int_0^T \int_\Omega v \tilde{p}(v, 0) dx dt \\
& \leq \|v\|_\rho \|\tilde{p}(v, 0)\|_{H_\rho(Q)} \leq C \|v\|_\rho^2,
\end{aligned}$$

which proves that  $\theta(v, 0)$  is bounded. Moreover, the map  $\tilde{p}(v, 0)(0) : U_{ad}^\rho \rightarrow L^2(\Omega)$  is continuous. In fact, by a Carleman estimate given in [2, Corollary 2.8], under the same condition of Theorem 1 there exists a  $C^2$  weighted positive function  $\rho$  on  $Q$  such that  $1/\rho$  is bounded in  $Q$  and  $C = C(\Omega, T, \Gamma_0, \rho) > 0$  such that:

$$\int_\Omega \frac{1}{\rho(0)^2} |q(0)|^2 dx dt \leq C \left[ \int_0^T \int_\Omega \frac{1}{\rho^2} |Lq|^2 dx dt + \int_0^T \int_{\Gamma_0} \frac{1}{\rho^2} \left| \frac{\partial q}{\partial \nu} \right|^2 d\Gamma dt \right]$$

for every  $q \in \mathcal{V}$ . Choose  $q = \tilde{p}(v, 0)$  to find

$$\int_\Omega \frac{1}{\rho(0)^2} |\tilde{p}(v, 0)(0)|^2 dx dt \leq C \left[ \int_0^T \int_\Omega \frac{1}{\rho^2} |L\tilde{p}(v, 0)|^2 dx dt + \|\theta(v, 0)\|_{L^2(\Sigma_0)}^2 \right] \leq C \|v\|_\rho^2.$$

Finally,  $S$  is also a linear bounded operator.  $\square$

Unfortunately, we encounter a big difficulty when characterizing the no-regret control where we need to know the structure of the set

$$\{v \in U_{ad}^\rho : (S(v), g)_{L^2(\Omega)} = 0 \text{ for every } g \in L^2(\Omega)\},$$

which is difficult to do, this requires on us to relax no-regret control definition by making some quadratic perturbation, then, we announce:

**Definition 2** [12]. *We say that  $u_\gamma \in U_{ad}^\rho$  is a low-regret control for (4.1), (4.2), (2.6) if  $u_\gamma$  is the solution of the problem:*

$$\inf_{v \in U_{ad}^\rho} \left( \sup_g \in L^2(\Omega) (J_\rho(v, g) - J_\rho(0, g) - \gamma \|g\|_{L^2(\Omega)}^2) \right), \quad \gamma > 0.$$

From (4.5), we get for all  $v \in U_{ad}^\rho$

$$\begin{aligned}
& \sup_{g \in L^2(\Omega)} \left( J_\rho(v, g) - J_\rho(0, g) - \gamma \|g\|_{L^2(\Omega)}^2 \right) \\
& = J_\rho(v, 0) - J_\rho(0, 0) + \sup_{g \in L^2(\Omega)} \left( 2(S(v), g)_{L^2(\Omega)} - \gamma \|g\|_{L^2(\Omega)}^2 \right) \\
& = J_\rho(v, 0) - J_\rho(0, 0) + \frac{1}{\gamma} \|S(v)\|_{L^2(\Omega)}^2.
\end{aligned}$$

Thus, our optimal control problem is transformed into a standard optimal control problem (i.e. a problem with complete data) given by

$$\inf_{v \in U_{ad}^\rho} \mathcal{J}_\rho^\gamma(v), \quad (4.6)$$

where

$$\mathcal{J}_\rho^\gamma(v) = J_\rho(v, 0) - J_\rho(0, 0) + \frac{1}{\gamma} \|S(v)\|_{L^2(\Omega)}^2. \quad (4.7)$$

**Lemma 2.** *The problem (4.1), (4.2), (2.6), (4.6), (4.7) has a unique solution  $u_\gamma \in U_{ad}^\rho$ .*

**P r o o f.** We have for every  $v \in U_{ad}^\rho$  :  $\mathcal{J}_\rho^\gamma(v) \geq -J_\rho(0, 0) = -\|y_d\|_\rho^2$  then  $d_\gamma = \inf_{v \in U_{ad}^\rho} \mathcal{J}_\rho^\gamma(v)$  exists. Let  $(v_n^\gamma)$  be a minimizing sequence such that  $d_\gamma = \lim_{n \rightarrow \infty} \mathcal{J}_\rho^\gamma(v_n^\gamma)$ . We know that

$$\mathcal{J}_\rho^\gamma(v_n^\gamma) = J_\rho(v_n^\gamma, 0) - J_\rho(0, 0) + \frac{1}{\gamma} \|S(v_n^\gamma)\|_{L^2(\Omega)}^2 \leq d_\gamma + 1.$$

This implies the following bounds

$$\|v_n^\gamma\|_\rho \leq C_\gamma, \quad \|y(v_n^\gamma, 0)\|_\rho \leq C_\gamma, \quad \frac{1}{\sqrt{\gamma}} \|S(v_n^\gamma)\|_{L^2(\Omega)} \leq C_\gamma,$$

where  $C_\gamma$  is a positive constant independent of  $n$ . Then, there exists  $u_\gamma$  such that  $v_n^\gamma \rightharpoonup u_\gamma$  weakly in  $U_{ad}^\rho$  (closed), also  $y(v_n^\gamma, 0) \rightharpoonup y(u_\gamma, 0)$  weakly in  $L_\rho^2(Q)$  because of continuity w.r.t. the data.

Since  $S$  is bounded, then

$$S(v_n^\gamma) \rightharpoonup S(u_\gamma) \text{ weakly in } L^2(\Omega),$$

with

$$\mathcal{J}_\rho^\gamma(u_\gamma) \leq \liminf_{n \rightarrow \infty} \mathcal{J}_\rho^\gamma(v_n^\gamma)$$

and we conclude that

$$\mathcal{J}_\rho^\gamma(u_\gamma) = \inf_{v \in U_{ad}^\rho} \mathcal{J}_\rho^\gamma(v).$$

Since  $\mathcal{J}_\rho^\gamma(v)$  is strictly convex,  $u_\gamma$  is unique. □

It still remains to obtain an optimality system giving a characterization for low-regret control  $u_\gamma$  as follows

**Theorem 2.** *The low-regret control  $u_\gamma \in U_{ad}^\rho$  which is a solution to (4.1), (4.2), (2.6), (4.6), (4.7) is characterized by the following optimality system*

$$\begin{cases} Ly_\gamma = u_\gamma; & Lp_\gamma = y_\gamma - y_d & \text{in } Q, \\ y_\gamma(x, 0) = 0, \quad y'_\gamma(x, 0) = 0, & p_\gamma(x, 0) = 0, \quad p'_\gamma(x, 0) = 0, \\ y_\gamma(x, T) = 0, \quad y'_\gamma(x, T) = 0; & p_\gamma(x, T) = 0, \quad p'_\gamma(x, T) = 0 & \text{in } \Omega, \\ y_\gamma = \begin{cases} \theta(u_\gamma, 0) \\ 0 \end{cases}; & p_\gamma = \begin{cases} \lambda_\gamma, \\ 0, \end{cases} & \text{on } \Sigma_0, \\ & & \text{on } \Sigma \setminus \Sigma_0, \end{cases} \quad (4.8)$$

where  $\gamma > 0$ ,  $y_\gamma = y(u_\gamma, 0)$  and  $p_\gamma = p(u_\gamma)$ , with the following variational inequality

$$\left( T^*(Lp_\gamma) + Nu_\gamma + \frac{1}{\gamma} S^*S(u_\gamma), v - u_\gamma \right)_\rho \geq 0 \quad \forall v \in U_{ad}^\rho, \quad (4.9)$$

where  $T : v \rightarrow y(v, 0)$  from  $U_{ad}^\rho$  to  $L_\rho^2(Q)$  is a linear bounded operator.

**P r o o f.** A first order necessary condition of Euler–Lagrange [10] for (4.6), (4.7) gives for every  $v \in U_{ad}^\rho$

$$(y(u_\gamma, 0) - y_d, y(v - u_\gamma, 0))_\rho + N(u_\gamma, v - u_\gamma)_\rho + \frac{1}{\gamma} (S(u_\gamma), S(v - u_\gamma))_{L^2(\Omega)} \geq 0. \quad (4.10)$$

Denote  $y_\gamma = y(u_\gamma, 0)$  and let  $\sigma_\gamma = \sigma(u_\gamma)$  be the unique solution of the following variational equation

$$a(\sigma_\gamma, q) = \int_Q (y_\gamma - y_d) q dx dt \quad \forall q \in V. \quad (4.11)$$

Consider the pair  $(p_\gamma, \lambda_\gamma)$  given by

$$p_\gamma = \frac{1}{\rho^2} L \sigma_\gamma, \quad \lambda_\gamma = \frac{1}{\rho^2} \frac{\partial \sigma_\gamma}{\partial \nu} \Big|_{\Sigma_0},$$

then  $(p_\gamma, \lambda_\gamma)$  is the solution of the following backward wave equation

$$\begin{cases} Lp_\gamma = y_\gamma - y_d & \text{in } Q, \\ p_\gamma(x, T) = 0, \quad p'_\gamma(x, T) = 0 & \text{in } \Omega, \\ p_\gamma = \begin{cases} \lambda_\gamma & \text{on } \Sigma_0, \\ 0 & \text{on } \Sigma \setminus \Sigma_0, \end{cases} \end{cases} \quad (4.12)$$

with the null controllability propriety

$$p_\gamma(x, 0) = p'_\gamma(x, 0) = 0.$$

Rewrite the optimality condition (4.10) to be in the following form

$$(Lp_\gamma, y(v - u_\gamma, 0))_\rho + \left( Nu_\gamma + \frac{1}{\gamma} S^* S(u_\gamma), v - u_\gamma \right)_\rho \geq 0 \quad \forall v \in U_{ad}^\rho,$$

where

$$(Lp_\gamma, y(v - u_\gamma, 0))_\rho = (T^*(Lp_\gamma), v - u_\gamma)_\rho \quad \forall v \in U_{ad}^\rho,$$

which gives optimality condition (4.9).

The boundedness of  $T$  follows from the continuity of the solution to (2.2), (2.5) w.r.t. data.  $\square$

## 5. No-regret control optimality system (Optimal control for the ill-posed wave equation)

In this section, we will give an optimality system characterizing the optimal control (or the no-regret control) solution to (4.1), (4.2), (2.6), (4.4) by taking the limits of  $u_\gamma, y_\gamma, p_\gamma, \theta(u_\gamma, 0)$  and  $\lambda_\gamma$  when  $\gamma \rightarrow 0$ .

**Theorem 3.** *There exists a positive constant  $C$  independent of  $\gamma$  such that*

$$\|u_\gamma\|_\rho \leq C, \quad \|y_\gamma - y_d\|_\rho \leq C, \quad \|y_\gamma\|_\rho \leq C, \quad \|S(u_\gamma)\|_{L^2(\Omega)} \leq C\sqrt{\gamma}, \quad (5.1a)$$

$$\|\sigma_\gamma\|_\rho \leq C, \quad \|\theta(u_\gamma, 0)\|_{L^2(\Sigma_0)} \leq C, \quad \|\lambda_\gamma\|_{L^2(\Sigma_0)} \leq C, \quad (5.1b)$$

$$\|p_\gamma\|_{L^\infty(0, T; H_0^1(\Omega))} \leq C, \quad \|p'_\gamma\|_{L^\infty(0, T; L^2(\Omega))} \leq C.$$

P r o o f. Let  $u_\gamma$  is the unique solution for (4.1), (4.2), (2.6), (4.6), (4.7), then

$$\mathcal{J}_\rho^\gamma(u_\gamma) \leq \mathcal{J}_\rho^\gamma(0) = 0 \text{ i.e. } J_\rho(u_\gamma, 0) + \frac{1}{\gamma} \|S(u_\gamma)\|_{L^2(\Omega)}^2 \leq J_\rho(0, 0)$$

which give (5.1a).

Choose  $q = \sigma_\gamma$  in (4.11) with Lax–Milgram theorem stability estimates to prove that

$$\exists C > 0 : \|\sigma_\gamma\|_\rho \leq C,$$

where  $C$  is independent of  $\gamma$ . From continuity and (5.1a), we deduce the boundedness of  $\theta(u_\gamma, 0)$  and  $\lambda_\gamma$  in  $L^2(\Sigma_0)$ .

Multiply (4.12) by  $p'_\gamma$ , integrate by parts, and use (5.1a) with (5.1b) to find

$$\|p'_\gamma\|_{L^\infty(0,T;L^2(\Omega))}^2 + \|p_\gamma\|_{L^\infty(0,T;H_0^1(\Omega))}^2 \leq C \left( \|y_\gamma - y_d\|_{L^2(Q)}^2 + \|\lambda_\gamma\|_{L^2(\Sigma_0)}^2 \right) \leq C.$$

□

**Lemma 3.** *The low-regret control  $u_\gamma$  solution to (4.1), (4.2), (2.6), (4.6), (4.7) converges in  $U_{ad}^\rho$  to the no-regret control  $u$  solution to (4.1), (4.2), (2.6), (4.4).*

P r o o f. By (5.1a), we have

$$\|Ly_\gamma\|_\rho \leq C$$

and

$$\begin{aligned} u_\gamma &\rightharpoonup u \quad \text{weakly in } U_{ad}^\rho, \\ y_\gamma &\rightharpoonup y \quad \text{weakly in } L_\rho^2(Q). \end{aligned}$$

And by (5.1b) we have

$$\theta(u_\gamma, 0) \rightharpoonup \theta(u, 0) \quad \text{weakly in } L^2(\Sigma_0).$$

We conclude that  $y$  solves

$$\begin{cases} Ly = u & \text{in } Q, \\ y(0) = 0, \quad y'(0) = 0 & \text{in } \Omega, \\ y(T) = 0, \quad y'(T) = 0 & \text{in } \Omega, \\ y = \begin{cases} \theta(u, 0) & \text{on } \Sigma_0, \\ 0 & \text{on } \Sigma \setminus \Sigma_0. \end{cases} \end{cases}$$

Again, from (5.1a)

$$S(u_\gamma) \rightarrow 0 \quad \text{strongly in } L^2(\Omega),$$

then  $(S(u), g)_{L^2(\Omega)} = 0$  for every  $g$  in  $L^2(\Omega)$ , which means that  $u$  is a no-regret control solution to (4.1), (4.2), (2.6), (4.4). □

Finally, we can announce the following our main theorem characterizing the optimal control for the ill-posed wave equation (4.2).

**Theorem 4.** *The no-regret control  $u \in U_{ad}^\rho$  solution to (4.1), (4.2), (2.6), (4.5) is characterized by the following optimality system*

$$\begin{cases} Ly = u; & Lp = y - y_d & \text{in } Q, \\ y(x, 0) = 0, \quad y'(x, 0) = 0, & p(x, 0) = 0, \quad p'(x, 0) = 0, \\ y(x, T) = 0, \quad y'(x, T) = 0; & p(x, T) = 0, \quad p'(x, T) = 0 & \text{in } \Omega, \\ y = \begin{cases} \theta(u, 0) \\ 0 \end{cases}; & p = \begin{cases} \lambda \\ 0 \end{cases} & \text{on } \Sigma_0, \\ & & \text{on } \Sigma \setminus \Sigma_0, \end{cases} \quad (5.2)$$

where  $\lambda = \lim_{\gamma \rightarrow 0} \lambda_\gamma$ ,  $y = y(u, 0)$  and  $p = p(u)$ , with the following variational inequality

$$(T^*(Lp) + N\rho^2 u + S^*S(u), v - u)_{L^2(Q)} \geq 0 \quad \forall v \in U_{ad}^\rho.$$

**P r o o f.** We have already proved the convergence of  $y_\gamma$  to  $y$ , and  $u_\gamma$  to  $u$  in the proof of Lemma 3. For the rest, use (5.1a) to get

$$\|Lp_\gamma\|_\rho \leq C,$$

and (5.1b), to find

$$\lambda_\gamma \rightharpoonup \lambda \text{ weakly in } L^2(\Sigma_0),$$

Passing to the limit when  $\gamma \rightarrow 0$  in (4.8) we obtain the optimality system (5.2).  $\square$

## 6. Conclusion

To sum up, our work leads to solving the optimal control problem for an ill-posed wave equation without requiring the extra hypothesis of Slater. The main idea was to make a null controllability approach to deal with a well-posed equation with a missing initial condition. Then, we have applied the no-regret control method to solve the optimal control with incomplete data. The optimality system describing the optimal control is built by an overdetermined optimal state and adjoint state.

## Acknowledgements

The author wish to acknowledge the editor and anonymous reviewers for their insightful comments, which have improved the quality of this publication.

## REFERENCES

1. Baleanu D., Joseph C., Mophou G. Low-regret control for a fractional wave equation with incomplete data. *Adv. Difference Equ.*, 2016. Vol. 2016. Art. no. 240. P. 1–20. DOI: [10.1186/s13662-016-0970-8](https://doi.org/10.1186/s13662-016-0970-8)
2. Baudouin L., De Buhan M. and Ervedoza S. Global Carleman estimates for waves and applications. *Comm. Partial Differential Equations*, 2013. Vol. 38, No. 5. P. 823–859. DOI: [10.1080/03605302.2013.771659](https://doi.org/10.1080/03605302.2013.771659)
3. Berhail A., Omrane A. Optimal control of the ill-posed Cauchy elliptic problem. *Int. J. Differ. Equ.*, 2015. Vol. 2015. Art. no. 468918. P. 1–9. DOI: [10.1155/2015/468918](https://doi.org/10.1155/2015/468918)
4. Ciprian G., Gal. N.J. A spectral approach to ill-posed problems for wave equations. *Ann. Mat. Pura Appl. (4)*, 2008. Vol. 187, No. 4. P. 705–717. DOI: [10.1007/s10231-007-0063-0](https://doi.org/10.1007/s10231-007-0063-0)
5. Hafdallah A., Ayadi A., Laouar C. No-regret optimal control characterization for an ill-posed wave equation. *Int. J. Math. Trends Tech.*, 2017. Vol. 45, No. 3. P. 283–287. DOI: [10.14445/22315373/IJMTT-V41P528](https://doi.org/10.14445/22315373/IJMTT-V41P528)
6. Hafdallah A., Ayadi A. Optimal control of electromagnetic wave displacement with an unknown velocity of propagation. *Int. J. Control*, 2019. Vol. 92, No. 11. P. 2693–2700. (Published online: 2018) DOI: [10.1080/00207179.2018.1458157](https://doi.org/10.1080/00207179.2018.1458157)
7. Hafdallah A., Ayadi A. Optimal control of a thermoelastic body with missing initial conditions. *Int. J. Control*, 2020. Vol. 93, No. 7. P. 1570–1576. (Published online: 2018) DOI: [10.1080/00207179.2018.1519258](https://doi.org/10.1080/00207179.2018.1519258)
8. Hafdallah A. On the optimal control of linear systems depending upon a parameter and with missing data. *Nonlinear Stud.*, 2020. Vol. 27, No. 2. P. 457–469.
9. Jacob B., Omrane A. Optimal control for age-structured population dynamics of incomplete data. *J. Math. Anal. Appl.*, 2010. Vol. 370, No. 1. P. 42–48. DOI: [10.1016/j.jmaa.2010.04.042](https://doi.org/10.1016/j.jmaa.2010.04.042)

10. Lions J.L. *Optimal Control of Systems Governed by Partial Differential Equations*. Grundlehren Math. Wiss., vol. 170. Berlin, Heidelberg: Springer-Verlag, 1971. 400 p.
11. Lions J.L. *Control of Distributed Singular Systems*. Paris: Gauthier-Villars, 1985. 552 p.
12. Lions J.L. Contrôle à moindres regrets des systèmes distribués. *C. R. Acad. Sci. Paris. Sér. I, Math.*, 1992. Vol. 315, No. 12. P. 1253–1257.
13. Lions J.L. *No-Regret and Low-Regret Control, in Environment, Economics and Their Mathematical Models*. Paris: Masson, 1994.
14. Nakoulima O., Omrane A., Velin J. On the Pareto control and no-regret control for distributed systems with incomplete data. *SIAM J. Control Optim.*, 2003. Vol. 42, No. 4. P. 1167–1184. DOI: [10.1137/S0363012900380188](https://doi.org/10.1137/S0363012900380188)
15. Savage L.J. *The Foundations of Statistics*. 2nd ed. New York: Dover Publ., 1972. 310 p.

# GROWTH OF $\varphi$ -ORDER SOLUTIONS OF LINEAR DIFFERENTIAL EQUATIONS WITH MEROMORPHIC COEFFICIENTS ON THE COMPLEX PLANE

Mohamed Abdelhak Kara, Benharrat Belaïdi<sup>1</sup>

Department of Mathematics, Laboratory of Pure and Applied Mathematics,  
University of Mostaganem (UMAB), B. P. 227 Mostaganem, Algeria

<sup>1</sup>benharrat.belaidi@univ-mosta.dz

**Abstract:** In this paper, we study the growth of solutions of higher order linear differential equations with meromorphic coefficients of  $\varphi$ -order on the complex plane. By considering the concepts of  $\varphi$ -order and  $\varphi$ -type, we will extend and improve many previous results due to Chyzykhov–Semochko, Belaïdi, Cao–Xu–Chen, Kinnunen.

**Keywords:** Linear differential equations, Entire function, Meromorphic function,  $\varphi$ -order,  $\varphi$ -type.

## 1. Introduction

Let us consider the following linear differential equations

$$f^{(k)} + A_{k-1}(z)f^{(k-1)} + \dots + A_0(z)f = 0, \quad (1.1)$$

$$f^{(k)} + A_{k-1}(z)f^{(k-1)} + \dots + A_0(z)f = F(z), \quad (1.2)$$

where  $k \geq 2$ ,  $A_0 \not\equiv 0$  and  $F \not\equiv 0$ . It is well-known that if the coefficients  $A_0, A_1, \dots, A_{k-1}$  and  $F$  are entire functions, then all solutions of (1.1) and (1.2) are entire. The equation (1.1) has at least one solution of infinite order if some of coefficients are transcendental. For more details about the growth of solutions of equations (1.1) and (1.2), the reader can refer to [14]. In this paper, we use the standard notations of Nevanlinna value distribution theory of meromorphic functions (see [10, 14, 18, 22]). The term meromorphic function throughout this paper means meromorphic in the whole complex plane  $\mathbb{C}$ . This will not be recalled in the next statements.

To study the growth of meromorphic functions, we recall the following definitions. For all  $r \in \mathbb{R}$ , we define  $\exp_1 r = \exp r = e^r$  and  $\exp_{p+1} r = \exp(\exp_p r)$ ,  $p \in \mathbb{N} = \{1, 2, \dots\}$ . Inductively, for all  $r \in (0, +\infty)$  large enough, we define  $\log_1 r = \log r$  and  $\log_{p+1} r = \log(\log_p r)$ ,  $p \in \mathbb{N}$ . We also denote  $\exp_0 r = r = \log_0 r$ ,  $\exp_{-1} r = \log_1 r$  and  $\log_{-1} r = \exp_1 r$ .

**Definition 1** [13]. *The iterated  $p$ -order of a meromorphic function  $f$  is defined by*

$$\rho_p(f) := \limsup_{r \rightarrow +\infty} \frac{\log_p T(r, f)}{\log r}, \quad p \in \mathbb{N},$$

where  $T(r, f)$  is the Nevanlinna characteristic function of  $f$ . If  $f$  is an entire function, then the iterated  $p$ -order is defined as

$$\tilde{\rho}_p(f) := \limsup_{r \rightarrow +\infty} \frac{\log_{p+1} M(r, f)}{\log r} = \rho_p(f),$$

where  $M(r, f) = \max\{|f(z)| : |z| = r\}$  is the maximum modulus of  $f$ .



Note that  $\rho_1(f) = \rho(f)$  is the usual order and  $\rho_2(f)$  is the hyper-order.

**Definition 2** [13]. *The growth index of the iterated  $p$ -order of a meromorphic function  $f$  is defined by*

$$i(f) = \begin{cases} 0 & \text{if } f \text{ is rational,} \\ \min\{j \in \mathbb{N} : \rho_j(f) < +\infty\} & \text{if } f \text{ is transcendental and } \rho_j(f) < +\infty \text{ for some } j \in \mathbb{N}, \\ +\infty & \text{if } \rho_j(f) = +\infty \text{ for all } j \in \mathbb{N}. \end{cases}$$

Historically, Bernal [4] was the first one who introduced the idea of the iterated order to study the growth of solutions of complex differential equations. In [13], Kinnunen considered the growth of solutions of equations (1.1) and (1.2) with entire coefficients of a finite iterated  $p$ -order and extended many previous results obtained for the usual order and the hyper-order.

**Theorem A** [13]. *Let  $A_0(z), \dots, A_{k-1}(z)$  be entire functions such that  $i(A_0) = p$  ( $0 < p < \infty$ ). If either  $\max\{i(A_j) : j = 1, 2, \dots, k-1\} < p$  or  $\max\{\rho_p(A_j) : j = 1, 2, \dots, k-1\} < \rho_p(A_0)$ , then every solution  $f \not\equiv 0$  of equation (1.1) satisfies  $i(f) = p+1$  and  $\rho_{p+1}(f) = \rho_p(A_0)$ .*

In [3], the second author has extended Theorem A when most of the coefficients  $A_0(z), \dots, A_{k-1}(z)$  have the same order by using the concept of iterated  $p$ -type as follows.

**Theorem B** [3]. *Let  $A_0(z), \dots, A_{k-1}(z)$  be entire functions, and let  $i(A_0) = p$  ( $0 < p < \infty$ ). Assume that*

$$\max\{\rho_p(A_j) : j = 1, 2, \dots, k-1\} \leq \rho_p(A_0) = \rho \quad (0 < \rho < +\infty)$$

and

$$\max\{\tilde{\tau}_p(A_j) : \rho_p(A_j) = \rho_p(A_0)\} < \tilde{\tau}_p(A_0) = \tau \quad (0 < \tau < +\infty),$$

where

$$\tilde{\tau}_p(f) = \limsup_{r \rightarrow +\infty} \frac{\log_p M(r, f)}{r^{\rho_p(f)}}.$$

Then, every solution  $f \not\equiv 0$  of equation (1.1) satisfies  $i(f) = p+1$  and  $\rho_{p+1}(f) = \rho_p(A_0) = \rho$ .

In [5], Cao–Xu–Chen improved Theorems A and B by considering meromorphic coefficients instead of entire coefficients. In [16], Liu–Tu–Shi made a small modification in the original definition of  $[p, q]$ -order introduced by Juneja–Kapoor–Bajpai [11] in order to study the growth of entire solutions of equations (1.1) and (1.2). After that, Li and Cao [15] investigated the growth of meromorphic solutions of equations (1.1) and (1.2) with meromorphic coefficients of  $[p, q]$ -order which improved many results in [3, 5, 13, 16].

**Definition 3** [15, 16]. *Let  $p \geq q \geq 1$  be integers. The  $[p, q]$ -order of transcendental meromorphic function  $f$  is defined by*

$$\rho_{[p,q]}(f) = \limsup_{r \rightarrow +\infty} \frac{\log_p T(r, f)}{\log_q r}.$$

If  $f$  is transcendental entire function, then

$$\rho_{[p,q]}(f) = \limsup_{r \rightarrow +\infty} \frac{\log_{p+1} M(r, f)}{\log_q r}.$$

Note that  $\rho_{[p,1]}(f) = \rho_p(f)$  is the iterated  $p$ -order (see [13, 14]).

**Definition 4** [15]. The  $[p, q]$ -type of a meromorphic function  $f$  with  $[p, q]$ -order  $\rho_{[p, q]}(f) \in (0, +\infty)$  is defined by

$$\tau_{[p, q]}(f) = \limsup_{r \rightarrow +\infty} \frac{\log_{p-1} T(r, f)}{(\log_{q-1} r)^{\rho_{[p, q]}(f)}}.$$

**Definition 5** [15]. Let  $p \geq q \geq 1$  be integers. The  $[p, q]$ -convergence exponent of the sequence of zeros of a meromorphic function  $f$  is defined by

$$\lambda_{[p, q]}(f) = \limsup_{r \rightarrow +\infty} \frac{\log_p N(r, 1/f)}{\log_q r},$$

where  $N(r, 1/f)$  is the integrated counting function of zeros of  $f$  in  $\{z : |z| \leq r\}$ . Similarly, the  $[p, q]$ -convergence exponent of the sequence of distinct zeros of  $f$  is defined by

$$\bar{\lambda}_{[p, q]}(f) = \limsup_{r \rightarrow +\infty} \frac{\log_p \bar{N}(r, 1/f)}{\log_q r},$$

where  $\bar{N}(r, 1/f)$  is the integrated counting function of distinct zeros of  $f$  in  $\{z : |z| \leq r\}$ .

Here, we give two results due to Li-Cao in [15] concerning the growth of meromorphic solutions of equations (1.1) and (1.2) when the coefficients are meromorphic functions of  $[p, q]$ -order.

**Theorem C** [15]. Let  $A_0, A_1, \dots, A_{k-1}$  be meromorphic functions such that

$$\max \left\{ \rho_{[p, q]}(A_j), \lambda_{[p, q]} \left( \frac{1}{A_0} \right) : j = 1, \dots, k-1 \right\} < \rho_{[p, q]}(A_0) < +\infty.$$

Then every meromorphic solution  $f \not\equiv 0$  whose poles are of uniformly bounded multiplicities of equation (1.1) satisfies  $\rho_{[p+1, q]}(f) = \rho_{[p, q]}(A_0)$ .

If there exist some other coefficients  $A_j (j = 1, \dots, k-1)$  having the same  $[p, q]$ -order as  $A_0$ , then we have the following result.

**Theorem D** [15]. Let  $A_0, A_1, \dots, A_{k-1}$  be meromorphic functions such that  $\lambda_{[p, q]}(1/A_0) < \rho_{[p, q]}(A_0)$  and

$$\begin{aligned} \max \{ \rho_{[p, q]}(A_j) : j = 1, \dots, k-1 \} &= \rho_{[p, q]}(A_0) < +\infty, \\ \max \{ \tau_{[p, q]}(A_j) : \rho_{[p, q]}(A_j) = \rho_{[p, q]}(A_0) > 0, j = 1, \dots, k-1 \} &< \tau_{[p, q]}(A_0). \end{aligned}$$

Then any non-zero meromorphic solution  $f$  whose poles are of uniformly bounded multiplicities of (1.1) satisfies  $\rho_{[p+1, q]}(f) = \rho_{[p, q]}(A_0)$ .

It is clear that Theorem C and Theorem D improve respectively Theorem A and Theorem B from entire coefficients of iterated  $p$ -order to meromorphic coefficients of  $[p, q]$ -order. Recently, Chyzykhov and Semochko [7] showed that both definitions of iterated  $p$ -order and  $[p, q]$ -order have the disadvantage that they do not cover arbitrary growth (see [7, Example 1.4]). They introduced more general scale to measure the growth of entire solutions of equation (1.1) called the  $\varphi$ -order (see [20]).

**Definition 6** [7]. Let  $\varphi$  be an increasing unbounded function on  $[1, +\infty)$ . The  $\varphi$ -orders of a meromorphic function  $f$  are defined by

$$\rho_{\varphi}^0(f) = \limsup_{r \rightarrow +\infty} \frac{\varphi(e^{T(r, f)})}{\log r}, \quad \rho_{\varphi}^1(f) = \limsup_{r \rightarrow +\infty} \frac{\varphi(T(r, f))}{\log r}.$$

If  $f$  is an entire function, then the  $\varphi$ -orders are defined by

$$\tilde{\rho}_{\varphi}^0(f) = \limsup_{r \rightarrow +\infty} \frac{\varphi(M(r, f))}{\log r}, \quad \tilde{\rho}_{\varphi}^1(f) = \limsup_{r \rightarrow +\infty} \frac{\varphi(\log M(r, f))}{\log r}.$$

**Definition 7** [1]. Let  $\varphi$  be an increasing unbounded function on  $[1, +\infty)$ . We define the  $\varphi$ -types of a meromorphic function  $f$  with  $\varphi$ -order  $\in (0, +\infty)$  by

$$\tau_{\varphi}^0(f) = \limsup_{r \rightarrow +\infty} \frac{e^{\varphi(T(r,f))}}{r^{\rho_{\varphi}^0(f)}}, \quad \tau_{\varphi}^1(f) = \limsup_{r \rightarrow +\infty} \frac{e^{\varphi(T(r,f))}}{r^{\rho_{\varphi}^1(f)}}.$$

If  $f$  is an entire function, then the  $\varphi$ -types are defined as

$$\tilde{\tau}_{\varphi}^0(f) = \limsup_{r \rightarrow +\infty} \frac{e^{\varphi(M(r,f))}}{r^{\tilde{\rho}_{\varphi}^0(f)}}, \quad \tilde{\tau}_{\varphi}^1(f) = \limsup_{r \rightarrow +\infty} \frac{e^{\varphi(\log M(r,f))}}{r^{\tilde{\rho}_{\varphi}^1(f)}}.$$

By symbol  $\Phi$  we define the class of positive unbounded increasing functions on  $[1, +\infty)$ , such that  $\varphi(e^t)$  grows slowly, i. e.,  $\forall c > 0 : \lim_{r \rightarrow +\infty} \frac{\varphi(e^{ct})}{\varphi(e^t)} = 1$ .

*Example 1.* Let  $f$  be a meromorphic function. One can see that  $\varphi(r) = \log_p r$ , ( $p \geq 2$ ) belongs to the class  $\Phi$  and  $\varphi(r) = \log r \notin \Phi$ . Moreover, the  $\rho_{\varphi}^1(f)$  order of the function  $f$  coincides with its iterated  $p$ -order, i. e.,  $\rho_{\varphi}^1(f) = \rho_p(f)$ . As a particular case, for  $\varphi = \log_2 \in \Phi$  we have  $\rho_{\log_2}^0(f) = \rho_1(f)$  and  $\rho_{\log_2}^1(f) = \rho_2(f)$  which are respectively the usual order and the hyper-order of  $f$ .

The following result due to Chyzhykov–Semochko [7] investigates the growth of entire solutions of equation (1.1) when the coefficients are entire functions of  $\varphi$ -order.

**Theorem E** [7]. Let  $\varphi \in \Phi$  and  $A_0, A_1, \dots, A_{k-1}$  be entire functions such that

$$\max\{\rho_{\varphi}^0(A_j), j = 1, \dots, k-1\} < \rho_{\varphi}^0(A_0).$$

Then every solution  $f \not\equiv 0$  of (1.1) satisfies  $\rho_{\varphi}^1(f) = \rho_{\varphi}^0(A_0)$ .

We recall that the linear measure of a set  $E \subset (0, +\infty)$  is defined by

$$m(E) = \int_0^{+\infty} \chi_E(t) dt$$

and the logarithmic measure of a set  $F \subset (1, +\infty)$  is defined by

$$lm(F) = \int_1^{+\infty} \frac{\chi_F(t)}{t} dt,$$

where  $\chi_A$  is the characteristic function of a set  $A$ . The upper density of a set  $E \subset (0, +\infty)$  is defined by

$$\overline{dens}E = \limsup_{r \rightarrow +\infty} \frac{m(E \cap [0, r])}{r}.$$

The upper logarithmic density of a set  $F \subset (1, +\infty)$  is defined by

$$\overline{\log dens}F = \limsup_{r \rightarrow +\infty} \frac{lm(F \cap [1, r])}{\log r}.$$

**Definition 8** [10, 22]. For  $a \in \overline{\mathbb{C}} = \mathbb{C} \cup \{\infty\}$ , the deficiency of  $a$  with respect to a meromorphic function  $f$  is defined as

$$\delta(a, f) = \liminf_{r \rightarrow +\infty} \frac{m(r, 1/(f-a))}{T(r, f)} = 1 - \limsup_{r \rightarrow +\infty} \frac{N(r, 1/(f-a))}{T(r, f)}, \quad a \neq \infty,$$

$$\delta(\infty, f) = \liminf_{r \rightarrow +\infty} \frac{m(r, f)}{T(r, f)} = 1 - \limsup_{r \rightarrow +\infty} \frac{N(r, f)}{T(r, f)}.$$

Recently, the second author has studied the growth of entire solutions of equation (1.1) when the coefficients are entire functions of  $\varphi$ -order and obtained the following results.

**Theorem F** [2]. *Let  $G$  be a set of complex numbers  $z$  satisfying  $\overline{\log dens} \{ |z| : z \in G \} > 0$ . Let  $\varphi \in \Phi$  and let  $A_0, A_1, \dots, A_{k-1}$  be entire functions satisfying*

$$\max\{\rho_\varphi^0(A_j) : j = 0, 1, \dots, k-1\} \leq \alpha \quad (0 < \alpha < +\infty).$$

*Suppose, there exists a real number  $\beta$  satisfies  $0 < \beta < \alpha$  such that for any given  $\varepsilon$  ( $0 < 2\varepsilon < \alpha - \beta$ ), we have*

$$T(r, A_0) \geq \log(\varphi^{-1}((\alpha - \varepsilon) \log r))$$

and

$$T(r, A_j) \leq \log(\varphi^{-1}(\beta \log r)), \quad j = 1, \dots, k-1$$

*as  $|z| \rightarrow +\infty$  for  $z \in G$ . Then every non-zero solution  $f$  of equation (1.1) satisfies  $\rho_\varphi^1(f) = \alpha$ .*

**Theorem G** [1]. *Let  $A_0(z), \dots, A_{k-1}(z)$  be entire functions, and let  $\varphi \in \Phi$ . Assume that*

$$\max\{\tilde{\rho}_\varphi^0(A_j) : j = 1, \dots, k-1\} \leq \tilde{\rho}_\varphi^0(A_0) = \rho < +\infty \quad (0 < \rho < +\infty)$$

and

$$\max\{\tilde{\tau}_\varphi^0(A_j) : \tilde{\rho}_\varphi^0(A_j) = \tilde{\rho}_\varphi^0(A_0)\} < \tilde{\tau}_\varphi^0(A_0) = \tau \quad (0 < \tau < +\infty).$$

*Then every solution  $f \not\equiv 0$  of (1.1) satisfies  $\tilde{\rho}_\varphi^1(f) = \tilde{\rho}_\varphi^0(A_0)$ .*

## 2. Main results

The aim of this paper is to investigate the growth of meromorphic solutions of equations (1.1) and (1.2) with meromorphic coefficients of finite  $\varphi$ -order. By using the concept of  $\varphi$ -order, we can cover arbitrary growth of solutions of equations (1.1) and (1.2) which improves several results in [1–3, 5, 7, 13]. To do that, we firstly introduce the following quantities by an analogous manner with the definitions of the  $\varphi$ -orders.

**Definition 9.** *Let  $\varphi$  be an increasing unbounded function on  $[1, +\infty)$ . We define the  $\varphi$ -convergence exponents of the sequence of zeros of a meromorphic function  $f$  by*

$$\lambda_\varphi^0(f) = \limsup_{r \rightarrow +\infty} \frac{\varphi(e^{N(r, 1/f)})}{\log r}, \quad \lambda_\varphi^1(f) = \limsup_{r \rightarrow +\infty} \frac{\varphi(N(r, 1/f))}{\log r}.$$

*Similarly, the notations  $\bar{\lambda}_\varphi^0(f)$  and  $\bar{\lambda}_\varphi^1(f)$  can be used to denote the  $\varphi$ -convergence exponents of the sequence of distinct zeros of  $f$ .*

Now, we list our main results.

**Theorem 1.** *Let  $\varphi \in \Phi$  and  $A_0, A_1, \dots, A_{k-1}$  be meromorphic functions. Suppose, there exists one coefficient  $A_s$  ( $s \in \{0, 1, \dots, k-1\}$ ) such that*

$$\max \left\{ \rho_\varphi^0(A_j), \lambda_\varphi^0 \left( \frac{1}{A_s} \right) : j = 0, 1, \dots, k-1 \quad (j \neq s) \right\} < \rho_\varphi^0(A_s) < +\infty.$$

*Then every transcendental meromorphic solution  $f$  whose poles are of uniformly bounded multiplicities of (1.1) satisfies*

$$\rho_\varphi^1(f) \leq \rho_\varphi^0(A_s) \leq \rho_\varphi^0(f).$$

*Furthermore, if all solutions of (1.1) are meromorphic solutions, then there is at least one meromorphic solution, say  $f_1$ , verifies  $\rho_\varphi^1(f_1) = \rho_\varphi^0(A_0)$ .*

*Remark 1.* By setting  $\varphi(r) = \log_{p+1} r$  ( $p \geq 1$ ) in Theorem 1, we obtain Theorem 2.2 in [5].

**Theorem 2.** Let  $\varphi \in \Phi$  and  $A_0, A_1, \dots, A_{k-1}$  be meromorphic functions such that

$$\max \left\{ \lambda_{\varphi}^0 \left( \frac{1}{A_0} \right), \rho_{\varphi}^0(A_j) : j = 1, \dots, k-1 \right\} < \rho_{\varphi}^0(A_0) < +\infty.$$

Then every non-zero meromorphic solution  $f$  whose poles are of uniformly bounded multiplicities of (1.1) satisfies  $\rho_{\varphi}^1(f) = \rho_{\varphi}^0(A_0)$ .

*Remark 2.* Clearly, Theorem 2 is an extension of Theorem E from entire solutions of equation (1.1) to the case of meromorphic solutions of equation (1.1) with meromorphic coefficients instead of entire coefficients. Furthermore, by setting  $\varphi(r) = \log_{p+1} r$  ( $p \geq 1$ ) in Theorem 2, we obtain Theorem A when the coefficients of (1.1) are entire functions.

If there exist some other coefficients  $A_j$  ( $j = 1, \dots, k-1$ ) having the same  $\varphi$ -order as  $A_0$ , then we have the following result.

**Theorem 3.** Let  $\varphi \in \Phi$  and  $A_0, A_1, \dots, A_{k-1}$  be meromorphic functions such that  $\lambda_{\varphi}^0(1/A_0) < \rho_{\varphi}^0(A_0)$  and

$$\max \{ \rho_{\varphi}^0(A_j) : j = 1, \dots, k-1 \} \leq \rho_{\varphi}^0(A_0) = \rho_0 < +\infty, \quad (2.1)$$

$$\max \{ \tau_{\varphi}^0(A_j) : \rho_{\varphi}^0(A_j) = \rho_{\varphi}^0(A_0) > 0, j = 1, \dots, k-1 \} < \tau_{\varphi}^0(A_0) = \tau_0 (0 < \tau_0 < +\infty). \quad (2.2)$$

Then any non-zero meromorphic solution  $f$  whose poles are of uniformly bounded multiplicities of (1.1) satisfies  $\rho_{\varphi}^1(f) = \rho_{\varphi}^0(A_0)$ .

*Remark 3.* Namely, Theorem 3 extends Theorem G from entire solutions of equation (1.1) to meromorphic solutions. Furthermore, by setting  $\varphi(r) = \log_{p+1} r$  ( $p \geq 1$ ) in Theorem 3, we obtain Theorem 2.1 in [5] and Theorem B when the coefficients of (1.1) are entire functions.

**Theorem 4.** Let  $\varphi \in \Phi$  and  $A_0, A_1, \dots, A_{k-1}, F \neq 0$  be meromorphic functions such that  $\lambda_{\varphi}^0(1/A_0) < \rho_{\varphi}^0(A_0)$  and

$$\max \{ \rho_{\varphi}^1(F), \rho_{\varphi}^0(A_j) : j = 1, \dots, k-1 \} < \rho_{\varphi}^0(A_0) < +\infty. \quad (2.3)$$

Then every meromorphic solution  $f$  whose poles are of uniformly bounded multiplicities of (1.2) satisfies

$$\bar{\lambda}_{\varphi}^1(f) = \lambda_{\varphi}^1(f) = \rho_{\varphi}^1(f) = \rho_{\varphi}^0(A_0)$$

with at most one exceptional solution  $f_0$  satisfying  $\rho_{\varphi}^1(f_0) < \rho_{\varphi}^0(A_0)$ .

*Remark 4.* Theorem 4 is a counterpart of Theorem 1.6 in [15]. Moreover, if we choose  $\varphi(r) = \log_{p+1} r$  ( $p \geq 1$ ) in Theorem 4, then we obtain a special case of Theorem 2.6 in [21].

**Theorem 5.** Let  $\varphi \in \Phi$  and  $A_0, A_1, \dots, A_{k-1}, F \neq 0$  be meromorphic functions such that

$$\max \{ \rho_{\varphi}^0(A_j) : j = 0, \dots, k-1 \} < \rho_{\varphi}^1(F).$$

If all solutions  $f$  of (1.2) are meromorphic functions whose poles are of uniformly bounded multiplicities, then there holds  $\rho_{\varphi}^1(f) = \rho_{\varphi}^1(F)$  for all solutions of (1.2).

*Remark 5.* Theorem 5 is a counterpart of Theorem 1.7 in [15]. Furthermore, if we choose  $\varphi(r) = \log_{p+1} r$  ( $p \geq 1$ ) in Theorem 5, then we obtain a special case in [13, Remark 4.1, p. 399] when the coefficients of equation (1.1) are entire functions.

**Theorem 6.** Let  $G \subset (1, +\infty)$  be a set of complex numbers  $z$  satisfying

$$\overline{\log dens}\{|z| : z \in G\} > 0.$$

Let  $\varphi \in \Phi$  and  $A_0, A_1, \dots, A_{k-1}$  be meromorphic functions satisfying  $\delta(\infty, A_0) = \delta > 0$  and

$$\max\{\rho_\varphi^0(A_j) : j = 0, 1, \dots, k-1\} \leq \alpha \quad (0 < \alpha < +\infty).$$

Suppose, there exists a real number  $\beta$  satisfies  $0 < \beta < \alpha$  such that for any given  $\varepsilon$  ( $0 < 2\varepsilon < \alpha - \beta$ ), we have

$$T(r, A_0) \geq \log(\varphi^{-1}((\alpha - \varepsilon) \log r)) \quad (2.4)$$

and

$$T(r, A_j) \leq \log(\varphi^{-1}(\beta \log r)), \quad j = 1, \dots, k-1 \quad (2.5)$$

as  $|z| = r \rightarrow +\infty$  for  $z \in G$ . Then every non-zero meromorphic solution of equation (1.1) satisfies  $\rho_\varphi^1(f) = \alpha$ .

*Remark 6.* Theorem 6 extends Theorem F from entire solutions of equation (1.1) to meromorphic solutions.

**Theorem 7.** Let  $G \subset (1, +\infty)$  be a set of complex numbers  $z$  satisfying

$$\overline{\log dens}\{|z| : z \in G\} > 0.$$

Let  $\varphi \in \Phi$  and  $A_0, A_1, \dots, A_{k-1}, F \not\equiv 0$  be meromorphic functions satisfying

$$\max\{\rho_\varphi^0(A_j) : j = 0, 1, \dots, k-1\} < \alpha \quad (0 < \alpha < +\infty).$$

Suppose, there exists a real number  $\beta$  satisfies  $0 < \beta < \alpha$  such that for any given  $\varepsilon$  ( $0 < 2\varepsilon < \alpha - \beta$ ), we have

$$|A_0(z)| \geq \varphi^{-1}((\alpha - \varepsilon) \log r) \quad (2.6)$$

and

$$|A_j(z)| \leq \varphi^{-1}(\beta \log r), \quad j = 1, \dots, k-1 \quad (2.7)$$

as  $|z| = r \rightarrow +\infty$  for  $z \in G$ . Then, the following conclusions hold

- (i) If  $\rho_\varphi^1(F) \geq \alpha$ , then all meromorphic solutions  $f$  whose poles are of uniformly bounded multiplicities of equation (1.2) satisfy  $\rho_\varphi^1(f) = \rho_\varphi^1(F)$ .
- (ii) If  $\rho_\varphi^1(F) < \alpha$ , then every meromorphic solution  $f$  whose poles are of uniformly bounded multiplicities of (1.2) satisfies

$$\bar{\lambda}_\varphi^1(f) = \lambda_\varphi^1(f) = \rho_\varphi^1(f) = \alpha$$

with at most one exceptional solution  $f_0$  satisfying  $\rho_\varphi^1(f_0) < \alpha$ .

*Remark 7.* Clearly, Theorem 7 is an improvement of Theorem 1.15 in [2] from entire solutions of equation (1.2) to meromorphic solutions. Furthermore, Theorem 7 is a counterpart of Theorem 1.8 in [15].

### 3. Preliminary lemmas

**Proposition 1** [7]. *If  $\varphi \in \Phi$ , then*

$$\forall m > 0, \forall k \geq 0 : \frac{\varphi^{-1}(\log x^m)}{x^k} \longrightarrow +\infty, \quad x \rightarrow +\infty, \quad (3.1)$$

$$\forall \delta > 0 : \frac{\log \varphi^{-1}((1 + \delta)x)}{\log \varphi^{-1}(x)} \longrightarrow +\infty, \quad x \rightarrow +\infty. \quad (3.2)$$

*Remark 8* [7]. We can see that (3.2) implies that

$$\forall c > 0, \varphi(ct) \leq \varphi(t^c) \leq (1 + o(1))\varphi(t), \quad t \rightarrow +\infty. \quad (3.3)$$

**Proposition 2** [7]. *Let  $\varphi \in \Phi$  and  $f$  be an entire function. Then*

$$\rho_\varphi^j(f) = \tilde{\rho}_\varphi^j(f), \quad j = 0, 1.$$

**Lemma 1** [6]. *Let  $f$  be a meromorphic solution of equation (1.1), suppose that not all coefficients  $A_j$  are constants. Given a real number  $\gamma > 1$ , and denoting  $T(r) = \sum_{j=0}^{k-1} T(r, A_j)$ , then the inequalities*

$$\begin{aligned} \log m(r, f) &< T(r)\{(\log r) \log T(r)\}^\gamma & \text{if } s = 0, \\ \log m(r, f) &< r^{2s+\gamma-1}T(r)\{\log T(r)\}^\gamma & \text{if } s > 0 \end{aligned}$$

take place outside of an exceptional set  $E_s$  with  $\int_{E_s} t^{s-1} dt < +\infty$ .

**Lemma 2** [8]. *Let  $f_1, f_2, \dots, f_k$  be linearly independent meromorphic solutions of equation (1.1) with meromorphic coefficients  $A_0, A_1, \dots, A_{k-1}$ . Then*

$$m(r, A_j) = O\left(\log\left(\max_{1 \leq i \leq k} T(r, f_i)\right)\right), \quad j = 0, 1, \dots, k-1.$$

**Lemma 3** [9]. *Let  $f$  be a transcendental meromorphic function and let  $\alpha > 1$  be a given constant. Then, there exists a set  $E_1 \subset (1, +\infty)$  with finite logarithmic measure and a constant  $B_\alpha > 0$  that depends only on  $\alpha$  and  $i, j$  ( $j > i \geq 0$ ) such that for all  $z$  satisfying  $|z| = r \notin [0, 1] \cup E_1$ , we have*

$$\left| \frac{f^{(j)}(z)}{f^{(i)}(z)} \right| \leq B_\alpha \left\{ \frac{T(\alpha r, f)}{r} (\log^\alpha r) \log T(\alpha r, f) \right\}^{j-i}.$$

**Lemma 4** [12]. *Let  $f$  be a meromorphic function and  $\varphi \in \Phi$ . Then*

$$\rho_\varphi^j(f') = \rho_\varphi^j(f) \quad \text{for } j = 0, 1.$$

**Lemma 5** [7, 12]. *Let  $\varphi \in \Phi$  and  $f_1, f_2$  be two meromorphic functions. Then*

$$(i) \quad \rho_\varphi^j(f_1 + f_2) \leq \max\left\{\rho_\varphi^j(f_1), \rho_\varphi^j(f_2)\right\} \quad \text{and} \quad \rho_\varphi^j(f_1 f_2) \leq \max\left\{\rho_\varphi^j(f_1), \rho_\varphi^j(f_2)\right\} \quad \text{for } j = 0, 1.$$

$$(ii) \quad \text{If } \rho_\varphi^j(f_1) < \rho_\varphi^j(f_2), \text{ then } \rho_\varphi^j(f_1 + f_2) = \rho_\varphi^j(f_1 f_2) = \rho_\varphi^j(f_2) \text{ for } j = 0, 1.$$

**Lemma 6.** *Let  $\varphi \in \Phi$  and  $f$  be a meromorphic function. Then, for any set  $E_2 \subset [0, +\infty)$  with finite linear measure, there exists a sequence  $\{r_n, r_n \notin E_2\}$  such that*

$$\lim_{r_n \rightarrow +\infty} \frac{\varphi(T(r_n, f))}{\log r_n} = \rho_\varphi^1(f), \quad \left( \text{resp. } \lim_{r_n \rightarrow +\infty} \frac{\varphi(e^{T(r_n, f)})}{\log r_n} = \rho_\varphi^0(f) \right).$$

*P r o o f.* The definition of  $\rho_\varphi^1(f)$  implies that there exists a sequence  $\{s_n, n \geq 1\}, s_n \rightarrow +\infty$  such that

$$\lim_{s_n \rightarrow +\infty} \frac{\varphi(T(s_n, f))}{\log s_n} = \rho_\varphi^1(f).$$

Setting  $m(E_2) = \delta < +\infty$ . Then, for  $r_n \in [s_n, s_n + \delta + 1] \setminus E_2$ , we have

$$\frac{\varphi(T(r_n, f))}{\log r_n} \geq \frac{\varphi(T(s_n, f))}{\log(s_n + \delta + 1)} = \frac{\varphi(T(s_n, f))}{\log s_n + \log\left(1 + \frac{\delta + 1}{s_n}\right)}.$$

Hence

$$\lim_{r_n \rightarrow +\infty} \frac{\varphi(T(r_n, f))}{\log r_n} \geq \lim_{s_n \rightarrow +\infty} \frac{\varphi(T(s_n, f))}{\log s_n + \log\left(1 + \frac{\delta + 1}{s_n}\right)} = \rho_\varphi^1(f).$$

By

$$\lim_{r_n \rightarrow +\infty} \frac{\varphi(T(r_n, f))}{\log r_n} \leq \limsup_{r \rightarrow +\infty} \frac{\varphi(T(r, f))}{\log r} = \rho_\varphi^1(f),$$

we deduce that

$$\lim_{r_n \rightarrow +\infty} \frac{\varphi(T(r_n, f))}{\log r_n} = \rho_\varphi^1(f).$$

Similar proof for  $\rho_\varphi^0(f)$ . □

**Lemma 7.** *Let  $\varphi \in \Phi$  and  $f$  be a meromorphic function satisfying  $0 < \rho_\varphi^0(f) < +\infty$  and  $0 < \tau_\varphi^0(f) < +\infty$ . Then, for any given  $\eta < \tau_\varphi^0(f)$ , there exists a set  $E_3 \subset [0, +\infty)$  with infinite logarithmic measure such that for all  $r \in E_3$ , we have*

$$\varphi(e^{T(r, f)}) > \log(\eta r^{\rho_\varphi^0(f)}).$$

*P r o o f.* We denote  $\rho_\varphi^0(f) = \rho_0$  and  $\tau_\varphi^0(f) = \tau_0$ . The definition of  $\tau_\varphi^0(f)$  implies that there exists a sequence  $\{r_m, m \geq 1\}$  tending to  $+\infty$  satisfying

$$\left(1 + \frac{1}{m}\right)r_m < r_{m+1} \quad \text{and} \quad \lim_{m \rightarrow +\infty} \frac{e^{\varphi(e^{T(r_m, f)})}}{r_m^{\rho_0}} = \tau_0.$$

Then, for any given  $\varepsilon$  ( $0 < \varepsilon < \tau_0 - \eta$ ), there exists an integer  $m_1$  such that for all  $m \geq m_1$ , we have

$$e^{\varphi(e^{T(r_m, f)})} > (\tau_0 - \varepsilon)r_m^{\rho_0}. \tag{3.4}$$

Since  $\eta < \tau_0 - \varepsilon$ , there exists an integer  $m_2$  such that for all  $m \geq m_2$ , we have

$$\left(\frac{m}{m+1}\right)^{\rho_0} > \frac{\eta}{\tau_0 - \varepsilon}. \tag{3.5}$$

Taking  $m \geq m_3 = \max\{m_1, m_2\}$ , it follows from (3.4) and (3.5) that for any  $r \in [r_m, (1 + 1/m)r_m]$

$$e^{\varphi(e^{T(r, f)})} \geq e^{\varphi(e^{T(r_m, f)})} > (\tau_0 - \varepsilon)r_m^{\rho_0} \geq (\tau_0 - \varepsilon)\left(\frac{mr}{m+1}\right)^{\rho_0} > \eta r^{\rho_0}.$$



Thus

$$\varphi(e^{T(r,f)}) > \log(\eta r \rho_\varphi^0(f)).$$

Setting  $E_3 = \bigcup_{m=m_3}^{+\infty} [r_m, (1+1/m)r_m]$ , then the logarithmic measure  $lm(E_3)$  of  $E_3$  satisfies

$$lm(E_3) = \sum_{m=m_3}^{+\infty} \int_{r_m}^{(1+1/m)r_m} \frac{dt}{t} = \sum_{m=m_3}^{+\infty} \log\left(1 + \frac{1}{m}\right) = +\infty.$$

□

**Lemma 8.** *Let  $A_0, A_1, \dots, A_{k-1}, F \not\equiv 0$  be meromorphic functions and let  $f$  be a meromorphic solution of equation (1.2). If  $\max\{\rho_\varphi^1(F), \rho_\varphi^1(A_j) : j = 0, 1, \dots, k-1\} < \rho_\varphi^1(f)$ , then*

$$\bar{\lambda}_\varphi^1(f) = \lambda_\varphi^1(f) = \rho_\varphi^1(f).$$

*P r o o f.* Equation (1.2) can be written as

$$\frac{1}{f} = \frac{1}{F} \left( \frac{f^{(k)}}{f} + A_{k-1} \frac{f^{(k-1)}}{f} + \dots + A_1 \frac{f'}{f} + A_0 \right). \quad (3.6)$$

If  $f$  has a zero at  $z_0$  of order  $l > k$  and if  $A_0, A_1, \dots, A_{k-1}$  are all analytic at  $z_0$ , then  $F$  has a zero at  $z_0$  of order at least  $l - k$ . Then

$$n\left(r, \frac{1}{f}\right) \leq k \cdot \bar{n}\left(r, \frac{1}{f}\right) + n\left(r, \frac{1}{F}\right) + \sum_{j=0}^{k-1} n(r, A_j)$$

and

$$N\left(r, \frac{1}{f}\right) \leq k \cdot \bar{N}\left(r, \frac{1}{f}\right) + N\left(r, \frac{1}{F}\right) + \sum_{j=0}^{k-1} N(r, A_j). \quad (3.7)$$

By the lemma of logarithmic derivative [10] and (3.6), we get that

$$m\left(r, \frac{1}{f}\right) \leq m\left(r, \frac{1}{F}\right) + \sum_{j=0}^{k-1} m(r, A_j) + O(\log r + \log T(r, f)) \quad (3.8)$$

holds for all  $|z| = r \notin E_4$ , where  $E_4$  is a set of finite linear measure. By (3.7), (3.8) and the Nevanlinna's first main theorem, we obtain

$$\begin{aligned} T(r, f) &= T\left(r, \frac{1}{f}\right) + O(1) = m\left(r, \frac{1}{f}\right) + N\left(r, \frac{1}{f}\right) + O(1) \\ &\leq k \cdot \bar{N}\left(r, \frac{1}{f}\right) + T(r, F) + \sum_{j=0}^{k-1} T(r, A_j) + O(\log r + \log T(r, f)) \end{aligned} \quad (3.9)$$

holds for all sufficiently large  $r \notin E_4$ . We denote

$$\mu = \max\{\rho_\varphi^1(F), \rho_\varphi^1(A_j) \ (j = 0, 1, \dots, k-1)\}.$$

According to Lemma 6, there exists a sequence  $\{r_n, r_n \notin E_4\}$  such that

$$\lim_{r_n \rightarrow +\infty} \frac{\varphi(T(r_n, f))}{\log r_n} = \rho_\varphi^1(f) = \rho_1.$$

So, if  $r_n \notin E_4$ , then for any given  $\varepsilon$  ( $0 < 2\varepsilon < \rho_1 - \mu$ ) we get

$$T(r_n, f) \geq \varphi^{-1}((\rho_1 - \varepsilon) \log r_n). \quad (3.10)$$

We have

$$\max_{j=0,1,\dots,k-1} \{T(r_n, F), T(r_n, A_j)\} \leq \varphi^{-1}((\mu + \varepsilon) \log r_n), \quad (3.11)$$

$$O(\log r_n + \log T(r_n, f)) = o(T(r_n, f)). \quad (3.12)$$

Since  $\varepsilon$  ( $0 < 2\varepsilon < \rho_1 - \mu$ ), then from (3.10), (3.11) and Proposition 1, we obtain

$$\begin{aligned} \max_{j=0,1,\dots,k-1} \left\{ \frac{T(r_n, F)}{T(r_n, f)}, \frac{T(r_n, A_j)}{T(r_n, f)} \right\} &\leq \frac{\exp \{ \log \varphi^{-1}((\mu + \varepsilon) \log r_n) \}}{\exp \{ \log \varphi^{-1}((\rho_1 - \varepsilon) \log r_n) \}} \\ &= \exp \{ \log \varphi^{-1}((\mu + \varepsilon) \log r_n) - \log \varphi^{-1}((\rho_1 - \varepsilon) \log r_n) \} \\ &= \exp \left\{ \left( 1 - \frac{\log \varphi^{-1}((\rho_1 - \varepsilon) \log r_n)}{\log \varphi^{-1}((\mu + \varepsilon) \log r_n)} \right) \log \varphi^{-1}((\mu + \varepsilon) \log r_n) \right\} \longrightarrow 0 \end{aligned} \quad (3.13)$$

as  $r_n \rightarrow +\infty$ . By substituting (3.12) and (3.13) into (3.9) we deduce that for sufficiently large  $r_n \notin E_4$ , there holds

$$(1 - o(1))T(r_n, f) \leq k\bar{N} \left( r_n, \frac{1}{f} \right).$$

From this inequality, by the monotonicity of  $\varphi$  and (3.3), we obtain  $\rho_\varphi^1(f) \leq \bar{\lambda}_\varphi^1(f)$ . In addition, we have by definition that  $\bar{\lambda}_\varphi^1(f) \leq \lambda_\varphi^1(f) \leq \rho_\varphi^1(f)$ . Hence  $\bar{\lambda}_\varphi^1(f) = \lambda_\varphi^1(f) = \rho_\varphi^1(f)$ .  $\square$

**Lemma 9.** *Let  $f$  be a meromorphic function. If  $\rho_\varphi^0(f) = \rho < +\infty$ , then  $\rho_\varphi^1(f) = 0$ .*

*P r o o f.* Suppose that  $\rho_\varphi^0(f) = \rho < +\infty$ . Then, for any given  $\varepsilon > 0$  and sufficiently large  $r$ , we have

$$T(r, f) \leq \log(\varphi^{-1}((\rho + \varepsilon) \log r)).$$

By Karamata's theorem (see [19]), it follows that  $\varphi(e^t) = t^{o(1)}$  as  $t \rightarrow +\infty$ . Hence,

$$\begin{aligned} \rho_\varphi^1(f) &= \limsup_{r \rightarrow +\infty} \frac{\varphi(T(r, f))}{\log r} = \limsup_{r \rightarrow +\infty} \frac{\varphi(e^{\log T(r, f)})}{\log r} \\ &= \limsup_{r \rightarrow +\infty} \frac{(\log T(r, f))^{o(1)}}{\log r} \leq \limsup_{r \rightarrow +\infty} \frac{(\log \log(\varphi^{-1}((\rho + \varepsilon) \log r)))^{o(1)}}{\log r} = 0. \end{aligned}$$

$\square$

#### 4. Proofs of the main results

**Proof of Theorem 1.** (i) We first prove that  $\rho_\varphi^1(f) \leq \rho_\varphi^0(A_s) \leq \rho_\varphi^0(f)$  holds for every transcendental meromorphic function satisfying (1.1). From equation (1.1), we know that the poles of  $f$  can only occur at the poles of  $A_0, A_1, \dots, A_{k-1}$ , note that the multiplicities of poles of  $f$  are uniformly bounded, so we have

$$N(r, f) \leq C_1 \bar{N}(r, f) \leq C_1 \sum_{j=0}^{k-1} \bar{N}(r, A_j) \leq C \max\{N(r, A_j) : j = 0, 1, \dots, k-1\} \leq O(T(r, A_s)),$$

where  $C$  and  $C_1$  are two suitable positive constants. Hence

$$T(r, f) \leq m(r, f) + O(T(r, A_s)).$$

This inequality and Lemma 1 lead to

$$T(r, f) \leq m(r, f) + O(T(r, A_s)) \leq O(e^{T(r, A_s)[(\log r) \log T(r, A_s)]^\gamma}), \quad \gamma > 1$$

outside of an exceptional set  $E_0$  with finite logarithmic measure. By the monotonicity of the function  $\varphi$  and (3.3), we obtain  $\rho_\varphi^1(f) \leq \rho_\varphi^0(A_s)$ .

On the other hand, equation (1.1) can be written as

$$\begin{aligned} -A_s &= \frac{f^{(k)}}{f^{(s)}} + A_{k-1} \frac{f^{(k-1)}}{f^{(s)}} + \cdots + A_{s+1} \frac{f^{(s+1)}}{f^{(s)}} + A_{s-1} \frac{f^{(s-1)}}{f^{(s)}} + \cdots + A_0 \frac{f}{f^{(s)}} \\ &= \frac{f}{f^{(s)}} \left( \frac{f^{(k)}}{f} + A_{k-1} \frac{f^{(k-1)}}{f} + \cdots + A_{s+1} \frac{f^{(s+1)}}{f} + A_{s-1} \frac{f^{(s-1)}}{f} + \cdots + A_0 \right). \end{aligned}$$

By the lemma of logarithmic derivative and the fact that

$$m\left(r, \frac{f}{f^{(s)}}\right) \leq T(r, f) + T\left(r, \frac{1}{f^{(s)}}\right) = T(r, f) + T(r, f^{(s)}) + O(1) = O(T(r, f)),$$

it follows that

$$T(r, A_s) \leq N(r, A_s) + \sum_{j \neq s} m(r, A_j) + O(\log r + \log T(r, f)) + O(T(r, f)) \quad (4.1)$$

which holds for all  $|z| = r \notin E_5$  where  $E_5$  is a set of finite linear measure. By Lemma 6, it follows that there exists a sequence  $\{r_n, n \geq 1\}$ ,  $r_n \rightarrow +\infty$  such that for  $|z_n| = r_n \notin E_5$

$$\lim_{r_n \rightarrow +\infty} \frac{\varphi(e^{T(r_n, A_s)})}{\log r_n} = \rho_\varphi^0(A_s) = \rho_0$$

and so

$$T(r_n, A_s) \geq \log(\varphi^{-1}((\rho_0 - \varepsilon) \log r_n)). \quad (4.2)$$

Under the assumption  $\eta = \max\{\rho_\varphi^0(A_j), \lambda_\varphi^0(1/A_s) : j \neq s\} < \rho_\varphi^0(A_s) = \rho_0$ , we have

$$N(r_n, A_s) \leq \log(\varphi^{-1}((\eta + \varepsilon) \log r_n)), \quad (4.3)$$

$$m(r_n, A_j) \leq T(r_n, A_j) \leq \log(\varphi^{-1}((\eta + \varepsilon) \log r_n)), \quad j \neq s \quad (4.4)$$

provided for any given  $\varepsilon$  that verifies  $0 < 2\varepsilon < \rho_0 - \eta$ . Substituting (4.2), (4.3) and (4.4) into (4.1), we get

$$(1 - o(1)) \log(\varphi^{-1}((\rho_0 - \varepsilon) \log r_n)) \leq O(\log r_n + \log T(r_n, f)) + O(T(r_n, f)) = O(T(r_n, f)).$$

Applying (3.3), one can deduce that  $\rho_\varphi^0(A_s) = \rho_0 \leq \rho_\varphi^0(f)$ .

(ii) Now, we prove that there exists at least one meromorphic solution that satisfies  $\rho_\varphi^1(f) = \rho_\varphi^0(A_s)$ . Let  $\{f_1, f_2, \dots, f_k\}$  be a solution base of equation (1.1). By Lemma 2, we have

$$e^{m(r, A_s)} \leq O\left(\max_{1 \leq i \leq k} T(r, f_i)\right), \quad s \in \{1, 2, \dots, k-1\}.$$

If  $N(r, A_s) \geq m(r, A_s)$ , so  $T(r, A_s) \leq 2N(r, A_s)$ , then  $\rho_\varphi^0(A_s) \leq \lambda_\varphi^0\left(\frac{1}{A_s}\right)$ . This contradicts our assumption  $\lambda_\varphi^0\left(\frac{1}{A_s}\right) < \rho_\varphi^0(A_s)$  and asserts that  $N(r, A_s) < m(r, A_s)$ . Hence, for sufficiently large  $r$ , we have

$$e^{T(r, A_s)} = O(e^{m(r, A_s)}) \leq O\left(\max_{1 \leq i \leq k} T(r, f_i)\right).$$

This implies that there exists at least one solution of  $\{f_1, f_2, \dots, f_k\}$ , say  $f_1$ , that satisfies  $e^{T(r, A_s)} \leq O(T(r, f_1))$ . By this inequality and (3.3) and the monotonicity of  $\varphi$ , we obtain

$$\rho_\varphi^0(A_s) \leq \rho_\varphi^1(f_1).$$

We have proved in the first part that  $\rho_\varphi^1(f_1) \leq \rho_\varphi^0(A_s)$ . Therefore,  $\rho_\varphi^1(f_1) = \rho_\varphi^0(A_s)$ .  $\square$

**Proof of Theorem 2.** Assume that  $f$  is a non-zero meromorphic solution whose poles are of uniformly bounded multiplicities of (1.1). Equation (1.1) can be written as

$$A_0 = -\left(\frac{f^{(k)}}{f} + A_{k-1}\frac{f^{(k-1)}}{f} + \dots + A_1\frac{f'}{f}\right).$$

By the lemma of logarithmic derivative and the above equation, we have

$$\begin{aligned} m(r, A_0) &\leq \sum_{j=1}^{k-1} m(r, A_j) + \sum_{j=1}^k m\left(r, \frac{f^{(j)}}{f}\right) + O(1) \\ &\leq \sum_{j=1}^{k-1} m(r, A_j) + O(\log r + \log T(r, f)) \end{aligned} \quad (4.5)$$

holds possibly outside of an exceptional set  $E_6 \subset (0, +\infty)$  with finite linear measure. From this inequality, it follows

$$\begin{aligned} T(r, A_0) &= m(r, A_0) + N(r, A_0) \\ &\leq N(r, A_0) + \sum_{j=1}^{k-1} m(r, A_j) + O(\log r + \log T(r, f)) \end{aligned} \quad (4.6)$$

holds for  $r \notin E_6$ . By Lemma 6, it follows that there exists a sequence  $\{r_n, n \geq 1\}$ ,  $r_n \rightarrow +\infty$  such that for  $|z_n| = r_n \notin E_6$

$$\lim_{r_n \rightarrow +\infty} \frac{\varphi(e^{T(r_n, A_0)})}{\log r_n} = \rho_\varphi^0(A_0) = \rho_0$$

and so

$$T(r_n, A_0) \geq \log(\varphi^{-1}((\rho_0 - \varepsilon) \log r_n)) \quad (4.7)$$

under the assumption  $\eta = \max\{\rho_\varphi^0(A_j), \lambda_\varphi^0(1/A_0) : j \neq 0\} < \rho_\varphi^0(A_0) = \rho_0$ , we have

$$N(r_n, A_0) \leq \log(\varphi^{-1}((\eta + \varepsilon) \log r_n)), \quad (4.8)$$

$$m(r_n, A_j) \leq T(r_n, A_j) \leq \log(\varphi^{-1}((\eta + \varepsilon) \log r_n)), \quad j \neq 0 \quad (4.9)$$

provided for any given  $\varepsilon$  that verifies  $0 < 2\varepsilon < \rho_0 - \eta$ . Substituting (4.7), (4.8) and (4.9) into (4.6), we get

$$(1 - o(1)) \log(\varphi^{-1}((\rho_0 - \varepsilon) \log r_n)) \leq O(\log r_n + \log T(r_n, f)).$$

Applying (3.3), one can deduce that  $\rho_\varphi^0(A_0) = \rho_0 \leq \rho_\varphi^1(f)$ .

On the other hand, from Theorem 1, we have  $\rho_\varphi^0(A_0) \geq \rho_\varphi^1(f)$ . We deduce finally that every meromorphic solution  $f \neq 0$  whose poles are of uniformly bounded multiplicities of (1.1) satisfies  $\rho_\varphi^1(f) = \rho_\varphi^0(A_0)$ .  $\square$

**Proof of Theorem 3.** Assume that  $f$  is a non-zero meromorphic solution whose poles are of uniformly bounded multiplicities of (1.1). If  $\lambda_\varphi^0(1/A_0) < \rho_\varphi^0(A_0)$  and

$$\max\{\rho_\varphi^0(A_j) : j = 1, \dots, k-1\} < \rho_\varphi^0(A_0) < +\infty,$$

then by Theorem 2, we obtain  $\rho_\varphi^1(f) = \rho_\varphi^0(A_0)$ . Suppose that  $\lambda_\varphi^0(1/A_0) < \rho_\varphi^0(A_0)$  and

$$\begin{aligned} \max\{\rho_\varphi^0(A_j) : j = 1, \dots, k-1\} &= \rho_\varphi^0(A_0) = \rho_0 \quad (0 < \rho_0 < +\infty), \\ \max\{\tau_\varphi^0(A_j) : \rho_\varphi^0(A_j) = \rho_\varphi^0(A_0)\} &< \tau_\varphi^0(A_0) = \tau_0 \quad (0 < \tau_0 < +\infty). \end{aligned}$$

Then, there exists a set  $J \subseteq \{1, \dots, k-1\}$  such that  $\rho_\varphi^0(A_j) = \rho_\varphi^0(A_0) = \rho_0$  ( $j \in J$ ) and  $\tau_\varphi^0(A_j) < \tau_\varphi^0(A_0) = \tau_0$  ( $j \in J$ ). Hence, there exist two constants  $\beta_1$  and  $\beta_2$  such that

$$\max\{\tau_\varphi^0(A_j) : j \in J\} < \beta_1 < \beta_2 < \tau_\varphi^0(A_0) = \tau_0.$$

The definition of the type  $\tau_\varphi^0(A_j)$  implies that for  $r$  sufficiently large

$$e^{m(r, A_j)} \leq e^{T(r, A_j)} < \varphi^{-1}(\log(\beta_1 r^{\rho_0})), \quad j \in J \quad (4.10)$$

and

$$e^{m(r, A_j)} \leq e^{T(r, A_j)} < \varphi^{-1}(\log(r^{\rho_0})) < \varphi^{-1}(\log(\beta_1 r^{\rho_0})), \quad j \in \{1, \dots, k-1\} \setminus J, \quad (4.11)$$

where  $0 < \rho_0^0 < \rho_0$ . Since  $\lambda_0 = \lambda_\varphi^0(1/A_0) < \rho_\varphi^0(A_0) = \rho_0$ , then for any given  $\varepsilon$  ( $0 < 2\varepsilon < \rho_0 - \lambda_0$ ) and sufficiently large  $r$ , we have

$$e^{N(r, A_0)} \leq \varphi^{-1}(\log(r^{\lambda_0 + \varepsilon})) < \varphi^{-1}(\log(r^{\rho_0 - \varepsilon})) < \varphi^{-1}(\log(\beta_1 r^{\rho_0})). \quad (4.12)$$

By Lemma 7, there exists a set  $E_3 \subset [1, +\infty)$  with infinite logarithmic measure such that for all  $r \in E_3$ , we have

$$e^{T(r, A_0)} > \varphi^{-1}(\log(\beta_2 r^{\rho_0})). \quad (4.13)$$

By substituting (4.10), (4.11), (4.12) and (4.13) into (4.6), we obtain

$$(1 - o(1)) \log(\varphi^{-1}[\log(\beta_2 r^{\rho_0})]) \leq O(\log r + \log T(r, f)) \quad (4.14)$$

for all  $r \in E_3 \setminus E_6$ . Since  $E_3 \setminus E_6$  is a set of infinite logarithmic measure, then there exists a sequence of points  $|z_n| = r_n \in E_3 \setminus E_6$  tending to  $+\infty$ . Hence, by (4.14) we have

$$(1 - o(1)) \log(\varphi^{-1}[\log(\beta_2 r_n^{\rho_0})]) \leq O(\log r_n + \log T(r_n, f))$$

holds for all  $z_n$  satisfying  $|z_n| = r_n \in E_3 \setminus E_6$  as  $|z_n| = r_n \rightarrow +\infty$ . By the monotonicity of  $\varphi^{-1}$  and (3.3), we obtain  $\rho_\varphi^0(A_0) \leq \rho_\varphi^1(f)$ . By Theorem 1, we have  $\rho_\varphi^1(f) \leq \rho_\varphi^0(A_0)$ . Therefore  $\rho_\varphi^1(f) = \rho_\varphi^0(A_0)$  which completes the proof.  $\square$

**Proof of Theorem 4.** Since all solutions of equation (1.2) are meromorphic functions, all solutions of the homogeneous differential equation (1.1) corresponding to equation (1.2) are also

meromorphic functions. We assume that  $\{f_1, \dots, f_k\}$  is a meromorphic solution base of (1.1), then any solution of (1.2) has the form

$$f = c_1 f_1 + c_2 f_2 + \dots + c_k f_k, \quad (4.15)$$

where  $c_1, c_2, \dots, c_k$  are meromorphic functions satisfying

$$c'_j = F \cdot G_j(f_1, \dots, f_k) \cdot W^{-1}(f_1, \dots, f_k), \quad j = 1, 2, \dots, k, \quad (4.16)$$

where  $G_j(f_1, \dots, f_k)$  are differential polynomials in  $\{f_1, \dots, f_k\}$  and their derivatives and  $W^{-1}(f_1, \dots, f_k)$  is the Wronskian of  $\{f_1, \dots, f_k\}$ . We have by Theorem 2

$$\rho_\varphi^1(f_j) = \rho_\varphi^0(A_0), \quad j = 1, \dots, k.$$

By Lemma 4, Lemma 5, (4.15) and (4.16), we get

$$\rho_\varphi^1(f) \leq \max\{\rho_\varphi^1(f_j) \ (j = 1, \dots, k), \rho_\varphi^1(F)\} = \rho_\varphi^0(A_0).$$

In order to show that all solutions  $f$  of equation (1.2) satisfy  $\rho_\varphi^1(f) = \rho_\varphi^0(A_0)$  with at most one exceptional solution, say  $f_1$ , satisfying  $\rho_\varphi^1(f_1) < \rho_\varphi^0(A_0)$ , we suppose that there exist two distinct meromorphic solutions  $f_1$  and  $f_2$  of equation (1.2) satisfying  $\rho_\varphi^1(f_i) < \rho_\varphi^0(A_0)$ ,  $i = 1, 2$ . Then,  $f = f_1 - f_2$  is also a non-zero meromorphic solution of (1.1) and satisfies

$$\rho_\varphi^1(f) = \rho_\varphi^1(f_1 - f_2) \leq \max\{\rho_\varphi^1(f_1), \rho_\varphi^1(f_2)\} < \rho_\varphi^0(A_0)$$

which contradicts Theorem 2. By (2.3) for all solutions  $f$  of equation (1.2) satisfying  $\rho_\varphi^1(f) = \rho_\varphi^0(A_0)$ , by Lemma 9, we have

$$\max\{\rho_\varphi^1(F), \rho_\varphi^1(A_j) \ (j = 0, 1, \dots, k-1)\} = \rho_\varphi^1(F) < \rho_\varphi^0(A_0) = \rho_\varphi^1(f).$$

By Lemma 8, we have  $\bar{\lambda}_\varphi^1(f) = \lambda_\varphi^1(f) = \rho_\varphi^1(f)$  and hence Theorem 4 is proved.  $\square$

**Proof of Theorem 5.** Let  $f$  be a meromorphic solution of equation (1.2) and  $\{f_1, \dots, f_k\}$  be a meromorphic solution base of (1.1) corresponding to equation (1.2). By a similar discussion as in the proof of Theorem 4, it follows from Lemma 4, Lemma 5, (4.15) and (4.16) that

$$\rho_\varphi^1(f) \leq \max\{\rho_\varphi^1(f_j) \ (j = 1, \dots, k), \rho_\varphi^1(F)\}.$$

By the first part of the proof of Theorem 1, one can show easily that

$$\rho_\varphi^1(f_j) \leq \max\{\rho_\varphi^0(A_j) : j = 0, \dots, k-1\} \quad (4.17)$$

for  $j = 1, \dots, k$ . We obtain from the assumptions of Theorem 5 that  $\rho_\varphi^1(f_j) \leq \rho_\varphi^1(F)$  and thus

$$\rho_\varphi^1(f) \leq \rho_\varphi^1(F).$$

On the other hand, by Lemma 4, Lemma 5 and a simple order comparison from equation (1.2), we get

$$\rho_\varphi^1(F) \leq \max\{\rho_\varphi^1(A_j) \ (j = 0, \dots, k-1), \rho_\varphi^1(f)\}.$$

Since  $\rho_\varphi^1(A_j) \leq \rho_\varphi^0(A_j) < \rho_\varphi^1(F)$  ( $j = 0, \dots, k-1$ ), then

$$\rho_\varphi^1(F) \leq \rho_\varphi^1(f).$$

Therefore,  $\rho_\varphi^1(f) = \rho_\varphi^1(F)$ . □

**Proof of Theorem 6.** Assume that  $f$  is a non-zero meromorphic solution whose poles are of uniformly bounded multiplicities of (1.1). Set  $G_1 = \{|z| = r : z \in G\}$ , since  $\overline{\log dens}\{|z| : z \in G\} > 0$ , then  $G_1$  is a set with  $\int_{G_1} \frac{dr}{r} = +\infty$ . Set

$$\delta(\infty, A_0) = \liminf_{r \rightarrow +\infty} \frac{m(r, A_0)}{T(r, A_0)} = \delta > 0. \quad (4.18)$$

Thus, for sufficiently large  $r$ , we have

$$m(r, A_0) > \frac{1}{2}\delta T(r, A_0). \quad (4.19)$$

By substituting (2.4), (2.5) and (4.19) into (4.5), we obtain for sufficiently large  $r$  and any given  $\varepsilon$  ( $0 < 2\varepsilon < \alpha - \beta$ )

$$\begin{aligned} \frac{1}{2}\delta \log(\varphi^{-1}((\alpha - \varepsilon) \log r)) &\leq \frac{1}{2}\delta T(r, A_0) \leq m(r, A_0) \\ &\leq \sum_{j=1}^{k-1} m(r, A_j) + \sum_{j=1}^k m\left(r, \frac{f^{(j)}}{f}\right) + O(1) \\ &\leq \sum_{j=1}^{k-1} T(r, A_j) + O(\log r + \log T(r, f)) \\ &\leq (k-1) \log(\varphi^{-1}(\beta \log r)) + O(\log r + \log T(r, f)), \end{aligned}$$

it follows that

$$(1 - o(1)) \log(\varphi^{-1}((\alpha - \varepsilon) \log r)) \leq O(\log r + \log T(r, f)) \quad (4.20)$$

holds for all  $z$  satisfying  $|z| = r \in G_1 \setminus E_6$  as  $|z| = r \rightarrow +\infty$ . Since  $G_1 \setminus E_6$  is a set of infinite logarithmic measure, then there exists a sequence of points  $|z_n| = r_n \in G_1 \setminus E_6$  tending to  $+\infty$ . Hence, by (4.20) we have

$$(1 - o(1)) \log(\varphi^{-1}((\alpha - \varepsilon) \log r_n)) \leq O(\log r_n + \log T(r_n, f))$$

holds for all  $z_n$  satisfying  $|z_n| = r_n \in G_1 \setminus E_6$  as  $|z_n| = r_n \rightarrow +\infty$ . By the monotonicity of  $\varphi^{-1}$  and arbitrariness of  $\varepsilon$  ( $0 < 2\varepsilon < \alpha - \beta$ ), one can obtain  $\rho_\varphi^1(f) \geq \alpha$ .

On the other hand, it follows by a similar proof as in the first part of Theorem 1 that  $\rho_\varphi^1(f) \leq \alpha$ . Therefore  $\rho_\varphi^1(f) = \alpha$ . □

**Proof of Theorem 7.** (i) If  $\rho_\varphi^1(F) \geq \alpha$ , then it follows from Theorem 5 that  $\rho_\varphi^1(f) = \rho_\varphi^1(F)$ .

(ii) If  $\rho_\varphi^1(F) < \alpha$ , we prove that  $\rho_1 = \rho_\varphi^1(f) = \alpha$  for any non-zero meromorphic solution whose poles are of uniformly bounded multiplicities of (1.1). We show firstly that  $\rho_1 = \rho_\varphi^1(f) \geq \alpha$ . Without loss of the generality, we suppose the contrary  $\rho_1 \leq \beta < \alpha$ . Set  $G_2 = \{|z| = r : z \in G\}$ , since  $\overline{\log dens}\{|z| : z \in G\} > 0$ , then  $G_2$  is a set with  $\int_{G_2} \frac{dr}{r} = +\infty$ . From Lemma 3, there exists a set

$E_1 \subset (1, +\infty)$  with finite logarithmic measure and a constant  $B > 0$  such that for all  $z$  satisfying  $|z| = r \notin [0, 1] \cup E_1$ , we have

$$\left| \frac{f^{(j)}(z)}{f(z)} \right| \leq B[T(2r, f)]^{k+1}, \quad j = 1, \dots, k. \quad (4.21)$$

If  $f$  is a non-zero meromorphic solution of equation (1.1), then

$$|A_0(z)| \leq \left| \frac{f^{(k)}(z)}{f(z)} \right| + |A_{k-1}(z)| \left| \frac{f^{(k-1)}(z)}{f(z)} \right| + \cdots + |A_1(z)| \left| \frac{f'(z)}{f(z)} \right|. \quad (4.22)$$

By the definition of  $\rho_1 = \rho_\varphi^1(f)$  and substituting (2.6), (2.7), (4.21) into (4.22), we obtain

$$\begin{aligned} \varphi^{-1}((\alpha - \varepsilon) \log r) &\leq |A_0(z)| \leq k B \varphi^{-1}(\beta \log r) [T(2r, f)]^{k+1} \\ &\leq k B \varphi^{-1}(\beta \log r) \left[ \varphi^{-1} \left( \left( \rho_1 + \frac{\varepsilon}{2} \right) \log 2r \right) \right]^{k+1} \\ &\leq \left[ \varphi^{-1} \left( \left( \beta + \frac{\varepsilon}{2} \right) \log 2r \right) \right]^{k+2} \leq \varphi^{-1}((\beta + \varepsilon) \log r) \end{aligned} \quad (4.23)$$

holds for all  $z$  satisfying  $|z| = r \in G_2 \setminus ([0, 1] \cup E_1)$  as  $|z| = r \rightarrow +\infty$ . Since  $G_2 \setminus E_1$  is a set of infinite logarithmic measure, then there exists a sequence of points  $|z_n| = r_n \in G_2 \setminus E_1$  tending to  $+\infty$ . Hence, by (4.23) we have

$$\varphi^{-1}((\alpha - \varepsilon) \log r_n) \leq \varphi^{-1}((\beta + \varepsilon) \log r_n)$$

holds for all  $z_n$  satisfying  $|z_n| = r_n \in G_2 \setminus E_1$  as  $|z_n| = r_n \rightarrow +\infty$ . By the monotonicity of  $\varphi^{-1}$  and arbitrariness of  $\varepsilon (0 < 2\varepsilon < \alpha - \beta)$ , one can see that  $\alpha \leq \beta$  which contradicts our assumption. Then,  $\rho_\varphi^1(f) \geq \alpha$ .

On the other hand, it follows by a similar proof in Theorem 1 that

$$\rho_\varphi^1(f) \leq \alpha.$$

Therefore  $\rho_\varphi^1(f) = \alpha$ . In order to show that all solutions  $f$  of equation (1.2) satisfy  $\rho_\varphi^1(f) = \alpha$  with at most one exceptional solution, say  $f_0$ , satisfying  $\rho_\varphi^1(f_0) < \alpha$ , we suppose that there exist two distinct meromorphic solutions  $f_0$  and  $f_0^*$  of equation (1.2) satisfying  $\max \{ \rho_\varphi^1(f_0), \rho_\varphi^1(f_0^*) \} < \alpha$ . Then,  $f = f_0 - f_0^*$  is also a non-zero meromorphic solution of (1.1) and satisfies

$$\rho_\varphi^1(f) = \rho_\varphi^1(f_0 - f_0^*) \leq \max \{ \rho_\varphi^1(f_0), \rho_\varphi^1(f_0^*) \} < \alpha$$

which contradicts the proof of the first part of (ii). By assumptions of Theorem 7, for all solutions  $f$  of equation (1.2) satisfying  $\rho_\varphi^1(f) = \alpha$ , we have by Lemma 9

$$\max \{ \rho_\varphi^1(F), \rho_\varphi^1(A_j), j = 0, 1, \dots, k-1 \} = \rho_\varphi^1(F) < \alpha = \rho_\varphi^1(f).$$

By using Lemma 8, we obtain  $\bar{\lambda}_\varphi^1(f) = \lambda_\varphi^1(f) = \rho_\varphi^1(f)$  and hence

$$\bar{\lambda}_\varphi^1(f) = \lambda_\varphi^1(f) = \rho_\varphi^1(f) = \alpha$$

with at most one exceptional solution  $f_0$  satisfying  $\rho_\varphi^1(f_0) < \alpha$ .

## 5. Conclusion

In this paper, by using the concepts of  $\varphi$ -order and  $\varphi$ -type, we have studied the growth of meromorphic solutions of higher order linear differential equations when among meromorphic coefficients having the maximal  $\varphi$ -order, exactly one has its  $\varphi$ -type strictly greater than others. Many previous results due to Chyzykhov–Semochko, Belaidi, Cao–Xu–Chen, Kinnunen have been extended. Now, it is interesting to study the growth of meromorphic solutions of such equations by using the concept of  $(\alpha, \beta)$ -order called the generalized order introduced by Sheremeta [20], see the recent paper of Mulyava–Sheremeta–Trukhan [17].



### Acknowledgements

The authors are grateful to the referees for their many valuable remarks and suggestions which lead to the improvement of the original version of this paper.

This work was supported by the Directorate-General for Scientific Research and Technological Development (DGRSDT).

### REFERENCES

1. Belaïdi B. Fast growing solutions to linear differential equations with entire coefficients having the same  $\rho_\varphi$ -order. *J. Math. Appl.*, 2019. Vol. 42. P. 63–77. DOI: [10.7862/rf.2019.4](https://doi.org/10.7862/rf.2019.4)
2. Belaïdi B. Growth of  $\rho_\varphi$ -order solutions of linear differential equations with entire coefficients. *Pan-American Math. J.*, 2017. Vol. 27, No. 4. P. 26–42. URL: <http://www.internationalpubs.com>
3. Belaïdi B. Growth and oscillation of solutions to linear differential equations with entire coefficients having the same order. *Electron. J. Differential Equations*, 2009. No. 70. P. 1–10. URL: <https://ejde.math.txstate.edu>
4. Bernal L. G. On growth  $k$ -order of solutions of a complex homogeneous linear differential equation. *Proc. Amer. Math. Soc.*, 1987. Vol. 101, No. 2. P. 317–322. DOI: [10.1090/S0002-9939-1987-0902549-5](https://doi.org/10.1090/S0002-9939-1987-0902549-5)
5. Cao T.-B., Xu J. F., Chen Z. X. On the meromorphic solutions of linear differential equations on the complex plane. *J. Math. Anal. Appl.*, 2010. Vol. 364, No. 1. P. 130–142. DOI: [10.1016/j.jmaa.2009.11.018](https://doi.org/10.1016/j.jmaa.2009.11.018)
6. Chiang Y.-M., Hayman W. K. Estimates on the growth of meromorphic solutions of linear differential equations. *Comment. Math. Helv.*, 2004. Vol. 79, No. 3. P. 451–470. DOI: [10.1007/s00014-003-0792-7](https://doi.org/10.1007/s00014-003-0792-7)
7. Chyzhykov I., Semochko N. Fast growing entire solutions of linear differential equations. *Math. Bull. Shevchenko Sci. Soc.*, 2016. Vol. 13. P. 68–83.
8. Frank G., Hellerstein S. On the meromorphic solutions of non-homogeneous linear differential equations with polynomial coefficients. *Proc. London Math. Soc.*, 1986. Vol. s3–53, No. 3. P. 407–428. DOI: [10.1112/plms/s3-53.3.407](https://doi.org/10.1112/plms/s3-53.3.407)
9. Gundersen G. G. Estimates for the logarithmic derivative of a meromorphic function, plus similar estimates. *J. London Math. Soc.*, 1988. Vol. s2–37, No. 1. P. 88–104. DOI: [10.1112/jlms/s2-37.121.88](https://doi.org/10.1112/jlms/s2-37.121.88)
10. Hayman W. K. *Meromorphic Functions*. Oxford: Oxford Mathematical Monographs Clarendon Press, 1964. 191 p.
11. Juneja O. P., Kapoor G. P., Bajpai S. K. On the  $(p, q)$ -order and lower  $(p, q)$ -order of an entire function. *J. Reine Angew. Math.*, 1976. Vol. 282. P. 53–67. DOI: [10.1515/crll.1976.282.53](https://doi.org/10.1515/crll.1976.282.53)
12. Kara M. A., Belaïdi B. Some estimates of the  $\varphi$ -order and the  $\varphi$ -type of entire and meromorphic functions. *Int. J. Open Problems Complex Analysis*, 2019. Vol. 10, No. 3. P. 42–58. URL: <http://www.i-csrs.org>
13. Kinnunen L. Linear differential equations with solutions of finite iterated order. *Southeast Asian Bull. Math.* 1998. Vol. 22, No. 4. P. 385–405.
14. Laine I. *Nevanlinna Theory and Complex Differential Equations*. De Gruyter Studies in Mathematics, Vol. 15. Berlin: Walter de Gruyter & Co., 1993. 341 p. DOI: [10.1515/9783110863147](https://doi.org/10.1515/9783110863147)
15. Li L. M., Cao T. B. Solutions for linear differential equations with meromorphic coefficients of  $[p, q]$ -order in the plane. *Electron. J. Differential Equations*, 2012. No. 195. P. 1–15. URL: <https://ejde.math.txstate.edu>
16. Liu J., Tu J., Shi L. Z. Linear differential equations with entire coefficients of  $[p, q]$ -order in the complex plane. *J. Math. Anal. Appl.*, 2010. Vol. 372. P. 55–67. DOI: [10.1016/j.jmaa.2010.05.014](https://doi.org/10.1016/j.jmaa.2010.05.014)
17. Mulyava O. M., Sheremeta M. M., Trukhan Yu. S. Properties of solutions of a heterogeneous differential equation of the second order. *Carpathian Math. Publ.*, 2019. Vol. 11, No. 2. P. 379–398. DOI: [10.15330/cmp.11.2.379-398](https://doi.org/10.15330/cmp.11.2.379-398)
18. Nevanlinna R. Zur theorie der meromorphen funktionen. *Acta Math.*, 1925. Vol. 46, No. 1–2. P. 1–99. (in German). DOI: [10.1007/BF02543858](https://doi.org/10.1007/BF02543858)
19. Seneta E. *Regularly Varying Functions*. Lecture Notes in Math., Vol. 508. Berlin, Heidelberg: Springer-Verlag, 1976. 116 p. DOI: [10.1007/BFb0079658](https://doi.org/10.1007/BFb0079658)
20. Sheremeta M. N. Connection between the growth of the maximum of the modulus of an entire function and the moduli of the coefficients of its power series expansion. *Izv. Vyssh. Uchebn. Zaved. Mat.*, 1967. Vol. 2, P. 100–108. (in Russian)

- 
21. Tu J., Chen Z.-X. Growth of solutions of complex differential equations with meromorphic coefficients of finite iterated order. *Southeast Asian Bull. Math.*, 2009. Vol. 33, No. 1. P. 153–164.
  22. Yang L., *Value Distribution Theory*. Berlin, Heidelberg: Springer-Verlag, 1993. 269 p.  
DOI: [10.1007/978-3-662-02915-2](https://doi.org/10.1007/978-3-662-02915-2)

## A NEW GENERALIZED VARENTROPY AND ITS PROPERTIES

S. Maadani<sup>1</sup>, G. R. Mohtashami Borzadaran<sup>2</sup>, A. H. Rezaei Roknabadi<sup>3</sup>

Ferdowsi University of Mashhad, Azadi Square, Mashhad, Iran

<sup>1</sup>madani.sa@mail.um.ac.ir,   <sup>2</sup>grmohtashami@um.ac.ir,   <sup>3</sup>rezaei@um.ac.ir

**Abstract:** The variance of Shannon information related to the random variable  $X$ , which is called varentropy, is a measurement that indicates, how the information content of  $X$  is scattered around its entropy and explains its various applications in information theory, computer sciences, and statistics. In this paper, we introduce a new generalized varentropy based on the Tsallis entropy and also obtain some results and bounds for it. We compare the varentropy with the Tsallis varentropy. Moreover, we explain the Tsallis varentropy of the order statistics and analyse this concept in residual (past) lifetime distributions and then introduce two new classes of distributions by them.

**Keywords:** Generalized varentropy, Past Tsallis varentropy, Residual Tsallis varentropy, Tsallis varentropy, Varentropy.

### 1. Introduction

Nowadays, the use of information measures has an essential role in analyzing statistical issues and is greatly considered by the statisticians. Shannon [21] introduced a measure of uncertainty for the discrete random variable  $X$  with probability mass function  $P(x)$  to form into  $E(-\log P(X))$ , which is a basis for the information theory. The generalization of Shannon's measure for continuous random variable  $X$  with density function  $f(x)$  and support  $S$ , which is named a differential entropy, reads as follows:

$$h(X) = - \int_S f(x) \log f(x) dx. \quad (1.1)$$

This measure is the expectation of random variable  $(-\log f(X))$  and has recently attracted the attention of researchers.

In computer sciences, the variance of  $(-\log p(X))$  of the discrete random variable  $X$  is called the varentropy. This measure is an essential factor of the optimal code length calculation in the data compression process, dispersion of sources, and so on. To conduct further studies, we refer the reader to [3, 7, 15]. Since the varentropy was defined for discrete random variables, in this paper, we focus on the varentropy for continuous random variables, and we discuss it under the same name.

Let  $X$  be a continuous random variable with density function  $f$ . Then the varentropy of  $X$  is defined as

$$VE(X) = \text{Var}(-\log f(X)) = E[-\log f(X) - h(X)]^2, \quad (1.2)$$

where  $VE(X)$  is called the varentropy of  $X$ . Unfortunately, there are not many studies on the varentropy in the field of statistics. Song [22] introduced  $VE$  (of course not with that name), as an intrinsic measure of distributions shape, which can be an excellent alternative for the kurtosis measure. When the traditional kurtosis measure is not measurable, as Student's  $t$  distributions with degrees of freedom less than four, Cauchy and Pareto distributions,  $VE$  is a measure that can be used to compare the heavy-tailed distributions instead of kurtosis measure.

Liu [16] studied  $VE$  under the concept of information volatility and introduced some mathematical properties of it. He calculated  $VE$  for some distributions and showed that  $VE$  of gamma, beta (with parameters  $(\alpha, \alpha)$  when  $\alpha < 2 - \sqrt{2}$ ) and normal distributions are more than less than, and equal to  $1/2$  respectively, and that  $VE$  of the uniform distributions is zero. Therefore  $VE$  can separate the gamma, normal, beta and uniform distributions. He showed that  $VE$  of the generalized Gaussian distribution is exactly the reciprocal of its shape parameter, which gives us a new method to estimate this parameter. Zografos [29] found an empirical estimator for Song's measure in the elliptic multivariate distributions. Enomoto et al. [13] considered the multivariate normality test based on the sample measure of multivariate kurtosis defined by Song [22]. Afhami et al. [2] introduced the goodness of fit test based on entropy and varentropy of  $k$ -record values for the generalized Pareto distribution and more recently, in addition to the above, the application of the varentropy in reliability theory has been conducted in [10].

A generalization of the Shannon entropy is the Tsallis entropy (see [23]). Let  $X$  be a continuous random variable with density function  $f$ . Then the Tsallis entropy of order  $\alpha$  for  $X$  is defined as

$$I_T(X, \alpha) = \frac{1}{(1 - \alpha)} \left( \int_s f^\alpha(x) dx - 1 \right), \quad \alpha > 0, \quad \alpha \neq 1, \quad (1.3)$$

and if  $\alpha \rightarrow 1$ , then the Tsallis entropy is reduced to (1.1). The Tsallis entropy has many applications in physics, statistical mechanics and image processing. The properties of the Tsallis entropy have been investigated by several authors, see papers [17, 24, 25, 28].

On the other hand, the concentration of measure principle is one of the cornerstones in geometric functional analysis and probability theory, and it is widely used in many other areas. Hence the concentration property of information content  $(-\log f(X))$  is one of the central interests in information theory, and it has great relevance with various other areas such as probability theory, and the varentropy is the measure of this concentration. Suppose that  $X$  and  $Y$  are two random variables with the same Shannon entropy; for example, the Shannon entropy is zero in both standard uniform and the exponential (with the parameter  $e$ ) distributions. Can we say that the uncertainty criterion is the same in both random variables? In our opinion, our confidence in the measured value depends on the degree of information dispersion around the entropy. Therefore, for random variables with the less varentropy the uncertainty criteria are more appropriate. This concept is valid for the measure of the Tsallis uncertainty information, and if two random variables have the same Tsallis entropy, the Tsallis varentropy indicates which of these random variables has the more appropriate criterion for Tsallis uncertainty.

The purpose of this paper is to generalize Shannon's varentropy based on the Tsallis entropy, and compare its properties with Shannon's varentropy and extend it in the field of order statistics and reliability theory.

This paper contains the following sections. The generalized varentropy which we call  $TVE$  is introduced in Section 2. We also obtain some of its properties and compare  $TVE$  with  $VE$  in this section. In Section 3 we discuss the Tsallis varentropy of the order statistics. In Section 4, we study  $TVE$  in lifetime researches and achieve some bounds for it by hazard rate and reversed hazard rate functions. Moreover, we examine the effects of system's age on  $TVE$ . Finally, in Section 5, we introduce two new classes of distributions by residual and past Tsallis varentropy.

## 2. Introduction of Tsallis Varentropy

Let  $X$  be a continuous random variable with density function  $f$ . Then Tsallis entropy of order  $\alpha$  for  $X$  is the expectation of a random variable  $(f^\alpha(X) - 1)/(1 - \alpha)$  and  $TVE$  is the variance of it. Following what was said above, we define  $TVE$  and introduce some properties of this measure.

**Definition 1.** For the continuous random variable  $X$  with density function  $f$ , the Tsallis varentropy of order  $\alpha$  for  $X$  is defined as follows:

$$\begin{aligned} TVE(X, \alpha) &= \frac{1}{(1-\alpha)^2} \text{Var}(f^{\alpha-1}(X)) \quad \alpha > 0 \quad \alpha \neq 1 \\ &= \frac{1}{(1-\alpha)^2} \left( \int f^{2\alpha-1}(x) dx - \left( \int f^\alpha(x) dx \right)^2 \right), \end{aligned} \quad (2.1)$$

where  $TVE(X, \alpha)$  is the Tsallis varentropy of order  $\alpha$  for  $X$ . It is clear that when  $\alpha \rightarrow 1$ , (2.1) implies (1.2).

For example, if  $X \sim \text{Exp}(\theta)$  with density function  $f(x) = \theta e^{-\theta x}$  ( $x > 0$ ,  $\theta > 0$ ), then

$$TEV(X, \alpha) = \frac{1}{(1-\alpha)^2} \left( \frac{\theta^{2\alpha-2}}{2\alpha-1} - \left( \frac{\theta^{\alpha-1}}{\alpha} \right)^2 \right) = \frac{\theta^{2\alpha-2}}{\alpha^2(2\alpha-1)}, \quad \alpha > \frac{1}{2}. \quad (2.2)$$

We see that  $\lim_{\alpha \rightarrow 1} TVE(X, \alpha) = 1$  and that  $TVE(X, 1) = 1$  is the Shannon varentropy of the exponential distribution.

*Remark 1.* If  $X \sim \text{Exp}(\theta)$  and  $0 < \alpha \leq 1/2$ , then  $TVE(X, \alpha)$  diverges to infinity.

**Theorem 1.**  $X$  has a uniform distribution if and only if  $TVE(X, \alpha) = 0$  for all  $\alpha > 0$ .

*P r o o f.* If  $X \sim U(a, b)$  with density function  $f(x) = 1/(b-a)$  ( $a < x < b$ ), then

$$TEV(X, \alpha) = \frac{1}{(1-\alpha)^2} [(b-a)^{2-2\alpha} - ((b-a)^{1-\alpha})^2] = 0.$$

On the other hand, if  $TVE(X, \alpha) = 0$ , then  $\text{Var}(f^{\alpha-1}(X)) = 0$ , so  $f(X)$  is almost surely constant. Suppose that  $f(X) = c$  (if  $a < X < b$ ) is the support of  $X$ , then

$$\int_a^b f(x) dx = \int_a^b c dx \quad \text{and} \quad c = \frac{1}{b-a}.$$

□

Liu [16] showed that if  $X$  is a continuous random variable with symmetric density function  $f$  with respect to  $x = a$ , then  $VE(|X|) = VE(X)$ .

**Proposition 1.** Suppose that  $X$  is a continuous random variable with a symmetric density function  $f$  with respect to  $x = a$ . Then

$$TVE(|X|, \alpha) = 2^{2\alpha-2} TVE(X, \alpha).$$

*P r o o f.* Without loss of generality suppose  $a = 0$ . In this case the density function  $g(x)$  of the random variable  $|X|$  is  $g(x) = f(-x) + f(x) = 2f(x)$ , and hence

$$\begin{aligned} TVE(|X|, \alpha) &= \frac{1}{(1-\alpha)^2} \left( \int_0^\infty (2f(x))^{2\alpha-1} dx - \left[ \int_0^\infty (2f(x))^\alpha dx \right]^2 \right) \\ &= \frac{2^{2\alpha-2}}{(1-\alpha)^2} \left( \int_{-\infty}^\infty f^{2\alpha-1}(x) dx - \left[ \int_{-\infty}^\infty f^\alpha(x) dx \right]^2 \right) = 2^{2\alpha-2} TVE(X, \alpha). \end{aligned}$$

□

For example, if  $X$  has the Laplace distribution with density function  $f(x) = \frac{1}{2\beta}e^{-1/\beta \cdot |x|}$ , then we can show that

$$TVE(X, \alpha) = \frac{(2\beta)^{2-2\alpha}}{\alpha^2(2\alpha - 1)}, \quad \alpha > \frac{1}{2}.$$

On the other hand if  $X \sim Laplace(0, \beta)$ , then  $|X| \sim Exp(1/\beta)$ . Therefore by using (2.2), we have

$$TVE(|X|, \alpha) = \frac{(1/\beta)^{2\alpha-2}}{\alpha^2(2\alpha - 1)}, \quad \alpha > \frac{1}{2}.$$

It implies that  $TVE(|X|, \alpha) = 2^{2\alpha-2}TVE(X, \alpha)$ . It is obvious that if  $\alpha \rightarrow 1$ , then  $VE(|X|) = VE(X)$ .

One of the most important properties of  $VE$  is the following:

The varentropy is a scale and location invariant measure so  $VE(aX + b) = VE(X)$  for all  $a, b \in \mathbb{R}$ . This property implies that in the location and scale family of distributions,  $VE$  is independent of the distribution parameters. Therefore the empirical estimation of  $VE$  can separate the distribution of this family. Now the question arises, is  $TVE$  an affine invariant measure? To answer this question, let us look at the following theorem and at the next example.

**Theorem 2.** *Suppose that  $X$  is a continuous random variable and that  $f(x)$  is its density function. Then*

$$TVE(aX + b, \alpha) = a^{2-2\alpha}TVE(X, \alpha).$$

*P r o o f.* If  $Y = g(X)$  and  $g(X)$  is a strictly monotone function of  $X$ , then

$$f_Y(y) = \frac{f(g^{-1}(y))}{g'(g^{-1}(y))}.$$

It is easy to see that

$$TVE(g(X), \alpha) = \frac{1}{(1 - \alpha)^2} \text{Var} \left( \left( \frac{f(X)}{g'(X)} \right)^{\alpha-1} \right).$$

Therefore if  $g(X) = aX + b$ , then  $TVE(aX + b, \alpha) = a^{2-2\alpha}TVE(X, \alpha)$ . □

Theorem 2 implies that in the location and scale family of distributions, the Tsallis varentropy is independent of the location parameter but it depends on the scale parameter.

For example, if  $X \sim N(\mu, \sigma^2)$ , then  $TVE$  of  $X$  is

$$TEV(X, \alpha) = (2\pi\sigma^2)^{1-\alpha} \times \frac{1/\sqrt{2\alpha-1} - 1/\alpha}{(1-\alpha)^2}, \quad \alpha > \frac{1}{2}.$$

We can see that if  $\alpha \rightarrow 1$ ,  $TVE(X, 1) = VE(X) = 1/2$ , and  $TVE$  is reduced to  $VE$  of normal distribution, then we can see that  $TVE$  is dependent on the scale parameter  $\sigma^2$ .

**Definition 2.** *The Tsallis varentropy of order  $\alpha$  for a random vector  $\mathbf{X} = (X_1, X_2, \dots, X_n)$  with joint density function  $f(\mathbf{x})$ , is defined as follows:*

$$TVE(\mathbf{X}, \alpha) = \frac{1}{(1 - \alpha)^2} \left( \int_{\mathbb{R}^n} f^{2\alpha-1}(\mathbf{x})d\mathbf{x} - \left( \int_{\mathbb{R}^n} f^\alpha(\mathbf{x})d\mathbf{x} \right)^2 \right), \quad \alpha > 0, \quad \alpha \neq 1.$$

**Theorem 3.** *If  $\mathbf{X}$  is an  $n$ -dimensional random variable, then for any invertible  $n \times n$  matrix  $A$  and any  $n \times 1$  vector  $B$  we have  $TVE(A\mathbf{X} + B, \alpha) = |A|^{2-2\alpha}TVE(\mathbf{X}, \alpha)$ , where  $|A|$  is the determinant of the matrix  $A$ .*

Table 1. Comparison  $VE(X)$  and  $TVE(X, \alpha)$  (here  $\dot{\psi}(\cdot)$ ,  $\Gamma(\cdot)$  and  $B(a, b)$  are trigamma, gamma and beta functions respectively).

Distribution	Density function	$VE(X)$	$TVE(X, \alpha)$
uniform $(a, b)$	$f(x) = \frac{1}{b-a}$	0	0
exponential	$f(x) = \theta e^{-\theta x}$ , $\theta > 0, x > 0$	1	$\frac{\theta^{2\alpha-2}}{\alpha^2(2\alpha-1)}, \alpha > \frac{1}{2}$
Laplace	$f(x) = e^{- x-\mu /\sigma}/2\sigma$ , $\sigma > 0$	1	$\frac{(2\sigma)^{2-2\alpha}}{\alpha^2(2\alpha-1)}, \alpha > \frac{1}{2}$
Pareto	$f(x) = \theta\beta^\theta/x^{\theta+1}$ , $\beta > 0, \theta > 0, x > \beta$	$(\theta+1)^2 \times \frac{1}{\theta^2}$	$\frac{\beta^{2-2\alpha}\theta^{2\alpha}}{(1-\alpha)^2} \left\{ \frac{1}{\theta(\theta+1)(2\alpha-1)-\theta} - \frac{1}{[\alpha(\theta+1)-1]^2} \right\}$
normal	$f(x) = \frac{e^{-(x-\mu)^2/(2\sigma^2)}}{\sqrt{2\pi\sigma^2}}$	$\frac{1}{2}$	$(1-\alpha)^{-2}(2\pi\sigma^2)^{1-\alpha} \left( \frac{1}{\sqrt{2\alpha-1}} - \frac{1}{\alpha} \right), \alpha > \frac{1}{2}$
gamma	$f(x) = \frac{\lambda^\theta}{\Gamma(\theta)} x^{\theta-1} e^{-\lambda x}$ , $\theta > 0, \lambda > 0, x > 0$	$(\theta-1)^2 \dot{\psi}(\theta) - \theta + 2$	$(1-\alpha)^{-2} \left( \frac{\lambda^\theta}{\Gamma(\theta)} \right)^{2\alpha-1} \left\{ \frac{\Gamma((2\alpha-1)(\theta-1)+1)}{[(2\alpha-1)\lambda]^{(2\alpha-1)(\theta-1)+1}} - \frac{\lambda^\theta [\Gamma(\alpha(\theta-1)+1)]^2}{\Gamma(\theta)(\alpha\lambda)^{2\alpha(\theta-1)+2}} \right\}, \alpha > \frac{1}{2}$
Weibull	$f(x) = \theta\lambda^\theta x^{\theta-1} e^{-(\lambda x)^\theta}$ , $\theta > 0, \lambda > 0, x > 0$	$\dot{\psi}(1)(1-\theta^{-1})^2 + 2\theta^{-1} - 1$	$\frac{(\theta\lambda)^{2\alpha-2}}{(1-\alpha)^2} \left\{ \frac{\Gamma(\theta^{-1}(2\alpha-1)(\theta-1)+\theta^{-1})}{(2\alpha-1)^{[(2\alpha-1)(\theta-1)+\theta^{-1}]}} - \frac{\Gamma^2(\theta^{-1}\alpha(\theta-1)+\theta^{-1})}{\alpha^{[2\theta^{-1}\alpha(\theta-1)+2\theta^{-1}]}} \right\}$
beta	$f(x) = \frac{x^{m-1}(1-x)^{n-1}}{B(m, n)}$ , $0 < x < 1, m > 0, n > 0$	$(m-1)^2 \dot{\psi}(m) + (n-1)^2 \dot{\psi}(n)$	$\frac{B(m, n)^{1-2\alpha}}{(1-\alpha)^2} \left\{ B((2\alpha-1)(m-1)+1, (2\alpha-1)(n-1)+1) - B^{-1}(m, n) B^2(\alpha(m-1)+1, \alpha(n-1)+1) \right\}$
Rayleigh	$f(x) = \frac{x}{\sigma^2} e^{-x^2/(2\sigma^2)}$ , $x > 0, \sigma > 0$	$\frac{1}{4} \dot{\psi}(1)$	$\frac{2^{\alpha-1}\sigma^{2-2\alpha}}{(1-\alpha)^2} \left\{ \frac{\Gamma(\alpha)}{(2\alpha-1)^\alpha} - \frac{\Gamma^2((\alpha+1)/2)}{\alpha^{\alpha+1}} \right\}$

P r o o f. The proof is similar to Theorem 2 in the  $n$ -dimensional spaces. □

*Remark 2.* Theorems 2 and 3 indicate that  $TVE$  is a location-invariant measure but is not the scale-invariant, unless  $\alpha \rightarrow 1$ .

*Remark 3.* If  $X$  and  $Y$  are two random variables,  $X \sim \text{Exp}(\theta)$ ,  $Y \sim N(\mu, \sigma^2)$  and  $\text{Var}(X) = \text{Var}(Y)$  then

$$TVE(X, \alpha) = k(\alpha) TVE(Y, \alpha), \quad \alpha > \frac{1}{2},$$

where

$$k(\alpha) = (2\pi)^{\alpha-1} \frac{\alpha + \sqrt{2\alpha-1}}{\alpha\sqrt{2\alpha-1}},$$

and if  $\alpha \rightarrow 1$ , then  $VE(X) = 2VE(Y)$ .

In Table 1, we compare the  $VE$  and  $TVE$  for some continuous distributions.

**Theorem 4.** Let  $X_1, X_2, \dots, X_n$  be independent random variables with joint density function  $f(\mathbf{x})$ . Then

$$\begin{aligned}
 TVE(X_1, X_2, \dots, X_n, \alpha) &= \frac{1}{(1-\alpha)^2} \prod_{i=1}^n \{(1-\alpha)^2 TVE(X_i, \alpha) + [(1-\alpha)I_T(X_i, \alpha) + 1]^2\} \\
 &\quad - \frac{1}{(1-\alpha)^2} \prod_{i=1}^n \{[(1-\alpha)I_T(X_i, \alpha) + 1]^2\},
 \end{aligned}
 \tag{2.3}$$

and when  $\alpha \rightarrow 1$ , (2.3) reduces to

$$TVE(X_1, X_2, \dots, X_n, 1) = VE(X_1, X_2, \dots, X_n) = \sum_{i=1}^n VE(X_i).$$

**P r o o f.** If  $X_1, X_2, \dots, X_n$  are independent random variables, we know that

$$\text{Var} \left( \prod_{i=1}^n X_i \right) = \prod_{i=1}^n [\text{Var}(X_i) + E^2(X_i)] - \prod_{i=1}^n E^2(X_i).
 \tag{2.4}$$

Since  $f(x_1), \dots, f(x_n)$  are marginal density functions of  $f(\mathbf{x})$  and  $f^{\alpha-1}(X_1), \dots, f^{\alpha-1}(X_n)$  are independent random variables, (2.4) implies that

$$\begin{aligned}
 TVE(X_1, X_2, \dots, X_n, \alpha) &= \frac{1}{(1-\alpha)^2} \text{Var} \left( \prod_{i=1}^n f^{\alpha-1}(X_i) \right) \\
 &= \frac{1}{(1-\alpha)^2} \prod_{i=1}^n \text{Var} (f^{\alpha-1}(X_i) + E^2(f^{\alpha-1}(X_i))) - \frac{1}{(1-\alpha)^2} \prod_{i=1}^n E^2(f^{\alpha-1}(X_i)).
 \end{aligned}$$

Equation (1.3) indicates that  $E(f^{\alpha-1}(X)) = (1-\alpha)I_T(X, \alpha) + 1$ , and (2.1) implies

$$\text{Var} (f^{\alpha-1}(X)) = (1-\alpha)^2 TVE(X, \alpha).$$

Therefore

$$\begin{aligned}
 TVE(X_1, X_2, \dots, X_n, \alpha) &= \frac{1}{(1-\alpha)^2} \prod_{i=1}^n \{(1-\alpha)^2 TVE(X_i, \alpha) + [(1-\alpha)I_T(X_i, \alpha) + 1]^2\} \\
 &\quad - \frac{1}{(1-\alpha)^2} \prod_{i=1}^n \{[(1-\alpha)I_T(X_i, \alpha) + 1]^2\}.
 \end{aligned}$$

□

It is obvious that when  $\alpha \rightarrow 1$ , by using L'hospital's rule, we have

$$TVE(X_1, X_2, \dots, X_n, 1) = VE(X_1, X_2, \dots, X_n) = \sum_{i=1}^n VE(X_i).$$

**Corollary 1.** *If  $X$  and  $Y$  are two independent random variables with joint density function  $f(x, y)$  and marginal density functions  $f_X(x)$  and  $f_Y(y)$ , respectively, then*

$$\begin{aligned}
 TVE((X, Y), \alpha) &= (1-\alpha)^2 TVE(X, \alpha) TVE(Y, \alpha) + TVE(X, \alpha) [(1-\alpha)I_T(Y, \alpha) + 1]^2 \\
 &\quad + TVE(Y, \alpha) [(1-\alpha)I_T(X, \alpha) + 1]^2,
 \end{aligned}
 \tag{2.5}$$

where  $I_T(X, \alpha)$  and  $I_T(Y, \alpha)$  are Tsallis entropies of  $X$  and  $Y$  respectively, and (2.5) implies that  $TVE((X, Y), 1) = VE(X, Y) = VE(X) + VE(Y)$ .



**Corollary 2.** *By using (2.5), the following inequalities are valid:*

- (a)  $TVE((X, Y), \alpha) > (1 - \alpha)^2 TVE(X, \alpha) TVE(Y, \alpha)$ .  
 (b)  $TVE((X, Y), \alpha) > TVE(X, \alpha)[(1 - \alpha)I_T(Y, \alpha) + 1]^2 + TVE(Y, \alpha)[(1 - \alpha)I_T(X, \alpha) + 1]^2$ .

**Corollary 3.** *If  $X_1, X_2, \dots, X_n$  are iid random variables, then using Theorem 4 we have*

$$TVE(X_1, X_2, \dots, X_n, \alpha) = \frac{1}{(1 - \alpha)^2} \{ (1 - \alpha)^2 TVE(X_1, \alpha) + [(1 - \alpha)I_T(X_1, \alpha) + 1]^2 \}^n - \frac{1}{(1 - \alpha)^2} \{ [(1 - \alpha)I_T(X_1, \alpha) + 1]^2 \}^n.$$

**Theorem 5.** *Let  $X$  and  $Y$  be two random variables with joint density function  $f(x, y)$  and conditional density function  $f(x|y)$ . If*

$$E(f^{2\alpha-2}(X|Y)) \cdot E(f^{2\alpha-2}(Y)) \geq [E(f^{\alpha-1}(X, Y))]^2, \quad (2.6)$$

then

$$TVE((X, Y), \alpha) \geq (1 - \alpha)^{-2} \text{Cov}(f^{2\alpha-2}(X|Y), f^{2\alpha-2}(Y)), \quad (2.7)$$

and the equality established when  $X$  and  $Y$  are independent.

*P r o o f.* The joint density of  $X$  and  $Y$  is  $f(x, y) = f(x|y) \cdot f(y)$  therefore,

$$\begin{aligned} TVE((X, Y), \alpha) &= \frac{1}{(1 - \alpha)^2} \text{Var}(f^{\alpha-1}(X|Y) \cdot f^{\alpha-1}(Y)) \\ &= \frac{1}{(1 - \alpha)^2} \{ E(f^{2\alpha-2}(X|Y) \cdot f^{2\alpha-2}(Y)) - [E(f^{\alpha-1}(X|Y) \cdot f^{\alpha-1}(Y))]^2 \}. \end{aligned}$$

Using covariance definition we have

$$\text{Cov}(f^{2\alpha-2}(X|Y), f^{2\alpha-2}(Y)) = E(f^{2\alpha-2}(X|Y), f^{2\alpha-2}(Y)) - E(f^{2\alpha-2}(X|Y)) \cdot E(f^{2\alpha-2}(Y)),$$

therefore,

$$\begin{aligned} TVE((X, Y), \alpha) &= \frac{1}{(1 - \alpha)^2} \{ \text{Cov}(f^{2\alpha-2}(X|Y), f^{2\alpha-2}(Y)) + E(f^{2\alpha-2}(X|Y)) \cdot E(f^{2\alpha-2}(Y)) \\ &\quad - [E(f^{\alpha-1}(X, Y))]^2 \}. \end{aligned}$$

If (2.6) holds, then (2.7) will be easily obtained.  $\square$

### 3. Tsallis varentropy of order $\alpha$ for order statistics

Suppose that  $X_1, X_2, \dots, X_n$  are independent and identically distributed observations from density and cumulative function  $f$  and  $F$ , respectively. If we arrange of  $X_1, X_2, \dots, X_n$  from the smallest to the largest denoted as  $X_{1:n} \leq X_{2:n} \leq \dots \leq X_{n:n}$  and  $f_{i:n}$  denotes the density function of the  $i$ th order statistic, then

$$f_{i:n}(x) = \frac{1}{B(i, n - i + 1)} [F(x)]^{i-1} [1 - F(x)]^{n-i} f(x),$$

where

$$B(a, b) = \int_0^1 x^{a-1}(1-x)^{b-1} dx, \quad a > 0, \quad b > 0.$$

The order statistics have many applications in probability and statistics, as the characterization of distributions, goodness-of-fit test, reliability engineering, and many other problems. For more information, we refer the reader to [4, 8]. The order statistics also have been studied widely in information theory in [5, 12, 18, 26, 27]. Furthermore, the stochastic order is also has many applications in finance, risk theory, management science and biomathematics. For example, we refer the reader to scholarly researches such as [1, 6, 9, 11, 14, 19, 20]. In this section, we introduce the Tsallis varentropy of order  $\alpha$  for the  $i$ th order statistic. This measure can be one of the useful information measures for system designers. We know that one of the systems in reliability engineering is an  $(n - i + 1)$ -out-of- $n$  system, and the system is active, when at least  $(n - i + 1)$  components are operating. Assume that  $X_1, X_2, \dots, X_n$  denote the identical lifetime of the system components. Then the  $i$ th order statistic indicates the lifetime of the systems. In special cases,  $X_{1:n}$  and  $X_{n:n}$  are the lifetime of the series and parallel systems, respectively. Therefore the Tsallis entropy of the  $i$ th order statistic is a measure of the uncertainty of the lifetime system and the Tsallis varentropy is the volatility of this information.

**Definition 3.** Let  $X_1, X_2, \dots, X_n$  be a random sample from a continuous distribution with density function  $f$ . Let  $X_{i:n}$  denotes the  $i$ th order statistic. The Tsallis varentropy of  $i$ th order statistics is defined as:

$$TVE(X_{i:n}, \alpha) = \frac{1}{(1 - \alpha)^2} \text{Var}(f^{\alpha-1}(X_{i:n})) = (1 - \alpha)^{-2} \left\{ \int_S f_{i:n}^{2\alpha-1}(x) dx - \left( \int_S f_{i:n}^\alpha(x) dx \right)^2 \right\},$$

where  $S$  is the support of  $X_{i:n}$ .

In the following theorem we introduce a method for calculating the Tsallis varentropy for  $i$ th order statistic.

**Theorem 6.** Suppose that  $X$  is a continuous random variable with density function  $f$  and cumulative distribution function  $F$ , and let  $X_{i:n}$  denote the  $i$ th order statistic. Then the Tsallis varentropy of  $X_{i:n}$  can be expressed as:

$$TVE(X_{i:n}, \alpha) = (1 - \alpha)^{-2} [A_{i:n}(\alpha) - (B_{i:n}(\alpha))^2], \tag{3.1}$$

where

$$A_{i:n}(\alpha) = \frac{B((2\alpha - 1)(i - 1) + 1, (2\alpha - 1)(n - i) + 1)}{B^{2\alpha-1}(i, n - i + 1)} E(f^{2\alpha-2}(F^{-1}(T_i))), \tag{3.2}$$

and

$$B_{i:n}(\alpha) = \frac{B(\alpha(i - 1) + 1, \alpha(n - i) + 1)}{B^\alpha(i, n - i + 1)} E(f^{\alpha-1}(F^{-1}(Z_i))), \tag{3.3}$$

where  $Z_i$  has the beta distribution with parameters  $\alpha(i - 1) + 1$  and  $\alpha(n - i) + 1$  and  $T_i$  has the beta distribution with parameters  $(2\alpha - 1)(i - 1) + 1$  and  $(2\alpha - 1)(n - i) + 1$ .

*P r o o f* is parallel to [1, Lemma 2.1], we can prove that  $\int_s f_{i:n}^{2\alpha-1}(x) dx$  and  $\int_s f_{i:n}^\alpha(x) dx$  are equivalent (3.2) and (3.3) respectively. □

**Corollary 4.** The first and last Tsallis varentropy of order  $\alpha$  are:

$$TVE(X_{1:n}, \alpha) = (1 - \alpha)^{-2} \left\{ \frac{n^{2\alpha-1}}{(2\alpha - 1)(n - 1) + 1} E(f^{2\alpha-2}(F^{-1}(T_1))) - \left[ \frac{n^\alpha}{\alpha(n - 1) + 1} E(f^{\alpha-1}(F^{-1}(Z_1))) \right]^2 \right\}$$

and

$$TVE(X_{n:n}, \alpha) = (1 - \alpha)^{-2} \left\{ \frac{n^{2\alpha-1}}{(2\alpha - 1)(n - 1) + 1} E(f^{2\alpha-2}(F^{-1}(T_n))) - \left[ \frac{n^\alpha}{\alpha(n - 1) + 1} E(f^{\alpha-1}(F^{-1}(Z_n))) \right]^2 \right\}.$$

In the following theorem we show that if  $X$  has a symmetric density function with respect to  $x = a$ , then the Tsallis varentropy is symmetric with respect to  $i$ .

**Theorem 7.** *Suppose that  $X$  is a continuous random variable with the symmetric density function with respect to  $x = a$ , then*

$$TVE(X_{i:n}, \alpha) = TVE(X_{n-i+1:n}, \alpha).$$

**Proof.** If  $X$  has a symmetric density function with respect to  $x = a$ , then  $X + a$  has a symmetric density with respect to  $x = 0$ . Using the properties of order statistics  $X_{i:n} + a \stackrel{d}{=} -(X_{n-i+1:n} + a)$ , we have  $TVE(X_{i:n} + a, \alpha) = TVE(-X_{n-i+1:n} - a, \alpha)$ . Using Theorem 2, we have  $TVE(X_{i:n}, \alpha) = TVE(X_{n-i+1:n}, \alpha)$ .  $\square$

*Example 1.* If  $X \sim U(a, b)$  then

$$E(f^{2\alpha-2}(F^{-1}(T_i))) = \frac{1}{(b-a)^{2\alpha-2}} \quad \text{and} \quad E(f^{\alpha-1}(F^{-1}(Z_i))) = \frac{1}{(b-a)^{\alpha-1}}.$$

Using (3.2) and (3.3) we have:

$$A_{i:n}(\alpha) = \frac{(b-a)^{2-2\alpha} [B((2\alpha-1)(i-1)+1, (2\alpha-1)(n-i)+1)]}{B^{2\alpha-1}(i, n-i+1)}$$

and

$$B_{i:n}(\alpha) = \frac{(b-a)^{1-\alpha} [B(\alpha(i-1)+1, \alpha(n-i)+1)]}{B^\alpha(i, n-i+1)}.$$

Finally using (3.1) we get

$$TVE(X_{i:n}, \alpha) = \frac{(b-a)^{2-2\alpha}}{(1-\alpha)^2} \left\{ \frac{B((2\alpha-1)(i-1)+1, (2\alpha-1)(n-i)+1)}{B^{2\alpha-1}(i, n-i+1)} - \left[ \frac{B(\alpha(i-1)+1, \alpha(n-i)+1)}{B^\alpha(i, n-i+1)} \right]^2 \right\},$$

and also

$$TVE(X_{1:n}, \alpha) = TVE(X_{n:n}, \alpha) = \frac{(b-a)^{2-2\alpha}}{(1-\alpha)^2} \left\{ \frac{n^{2\alpha-1}}{(2\alpha-1)(n-1)+1} - \frac{n^{2\alpha}}{(\alpha(n-1)+1)^2} \right\}.$$

**Remark 4.** If  $TVE(X_{i:n}, \alpha) = TVE(X_{n-i+1:n}, \alpha)$  and  $TVE(X_{i:n}, \alpha)$  is decreasing with respect to  $i$  for  $i \leq (n+1)/2$  when  $n$  is odd (even), then  $TVE(X_{i:n}, \alpha)$  will be increasing with respect to  $i$  for  $i \geq (n+1)/2$ . Therefore the median (both random variables in the middle) of order statistics has a minimum Tsallis varentropy.

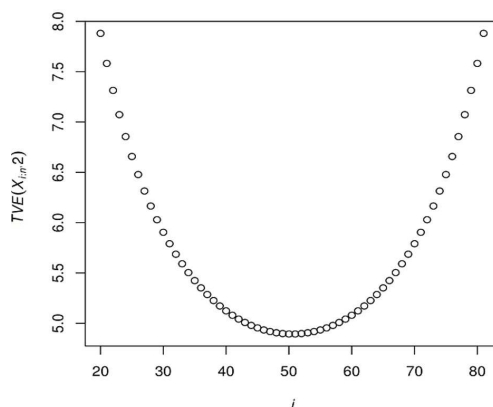

Figure 1.  $TVE(X_{i:n}, 2)$  versus  $i$  for the standard uniform distribution.

Figure 1 shows the Tsallis varentropy of  $i$ th order statistics for the uniform distribution and it is symmetric with respect to  $i$ .

*Example 2.* If  $X \sim \text{Exp}(\theta)$  according to Theorem 6 we have

$$E(f^{2\alpha-2}(F^{-1}(T_i))) = \frac{\theta^{2\alpha-2}B((2\alpha-1)(i-1)+1, (2\alpha-1)(n-i+1))}{B((2\alpha-1)(i-1)+1, (2\alpha-1)(n-i)+1)},$$

$$E(f^{\alpha-1}(F^{-1}(Z_i))) = \frac{\theta^{\alpha-1}B(\alpha(i-1)+1, \alpha(n-i+1))}{B(\alpha(i-1)+1, \alpha(n-i)+1)},$$

and

$$A_{i:n}(\alpha) = \frac{\theta^{2\alpha-2}B((2\alpha-1)(i-1)+1, (2\alpha-1)(n-i+1))}{B^{2\alpha-1}(i, n-i+1)},$$

$$B_{i:n}(\alpha) = \frac{\theta^{\alpha-1}B(\alpha(i-1)+1, \alpha(n-i+1))}{B^\alpha(i, n-i+1)},$$

finally

$$TVE(X_{i:n}, \alpha) = \frac{\theta^{2\alpha-2}}{(1-\alpha)^2} \left\{ \frac{B((2\alpha-1)(i-1)+1, (2\alpha-1)(n-i+1))}{B^{2\alpha-1}(i, n-i+1)} - \left[ \frac{B(\alpha(i-1)+1, \alpha(n-i+1))}{B^\alpha(i, n-i+1)} \right]^2 \right\}.$$

Figures 2a–2c show the Tsallis varentropy of  $i$ th order statistics for the exponential distribution for  $\theta = 2$  and some selected values for  $\alpha$ . When  $\alpha \rightarrow 1$ , the symmetric property is observed.

#### 4. The Tsallis varentropy in lifetime study

In reliability science, the hazard rate and reversed hazard rate functions are essential functions that can help engineers to analyze the system’s disability. If  $f$  and  $\bar{F}$  are density and survival function, respectively, the hazard rate and reversed hazard functions of  $X$  are  $r(x) = f(x)/\bar{F}(x)$  and  $\mu(x) = f(x)/F(x)$ , respectively. We know that if a lifetime distribution has an increasing (decreasing) hazard rate, then it is called the *IFR(DFR)* distribution, and if it has an increasing

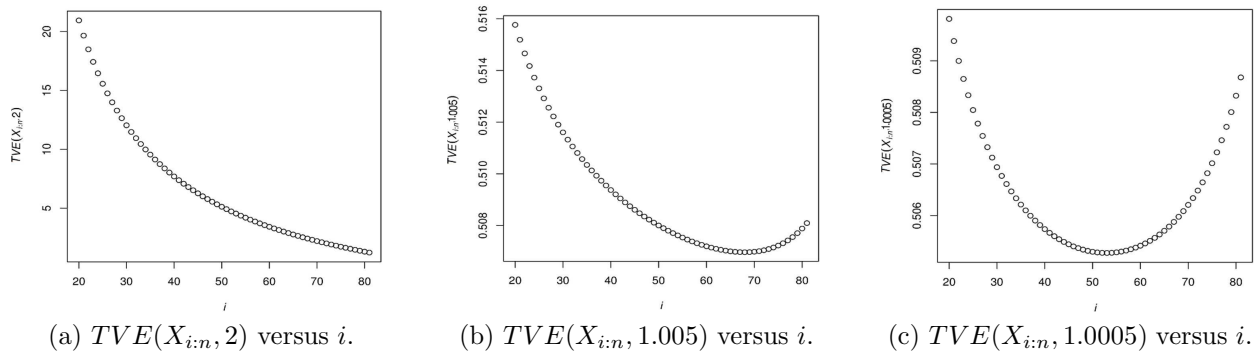

Figure 2.  $TVE(X_{i:n}, \alpha)$  versus  $i$  for the exponential distribution and  $\theta = 2$  and  $n = 100$ .

(decreasing) reversed hazard rate, then it is called the *IRFR(DRFR)*. In this part, we introduce some bounds by hazard and reversed hazard rate functions for *TVE* and study them in residual (past) and double truncated lifetime distributions and also we examine the effect of system's age on them.

**Theorem 8.** *Let  $X$  be a nonnegative continuous random variable and let  $r(x)$  be the hazard rate function of it. Then*

$$(a) \quad TVE(X, \alpha) = \frac{1}{(1 - \alpha)^2} \left\{ \text{Cov} (r^{2\alpha-2}(X), \bar{F}^{2\alpha-2}(X)) + \frac{E(r^{2\alpha-2}(X))}{2\alpha - 1} - \frac{E^2(r^{\alpha-1}(X))}{\alpha^2} \right\}, \quad (4.1)$$

$$(b) \quad TVE(X, \alpha) < (>) \frac{1}{(1 - \alpha)^2} \left\{ \text{Cov} (r^{2\alpha-2}(X), \bar{F}^{2\alpha-2}(X)) \right\}, \quad \text{if } 0 < \alpha < \frac{1}{2} \quad \left( \alpha > \frac{1}{2} \right), \quad (4.2)$$

$$(c) \quad TVE(X, \alpha) < (>) \frac{1}{(1 - \alpha)^2} \left\{ \frac{E(r^{2\alpha-2}(X))}{2\alpha - 1} - \frac{E^2(r^{\alpha-1}(X))}{\alpha^2} \right\}, \quad \text{if } F \text{ is } IFR(DFR). \quad (4.3)$$

*P r o o f.* It is obvious that

$$TVE(X, \alpha) = \frac{1}{(1 - \alpha)^2} \text{Var} (r^{\alpha-1}(X) \bar{F}^{\alpha-1}(X)).$$

On the other hand,

$$\text{Var} (XY) = \text{Cov} (X^2, Y^2) + E(X^2)E(Y^2) - (E(X)E(Y))^2. \quad (4.4)$$

Using (4.4), we have

$$TVE(X, \alpha) = \frac{1}{(1 - \alpha)^2} \left\{ \text{Cov} (r^{2\alpha-2}(X), \bar{F}^{2\alpha-2}(X)) + E(r^{2\alpha-2}(X)) \cdot E(\bar{F}^{2\alpha-2}(X)) - [E(r^{\alpha-1}(X)) \cdot E(\bar{F}^{\alpha-1}(X))]^2 \right\}.$$

Since  $E(\bar{F}^{2\alpha-2}(X)) = 1/(2\alpha - 1)$  and  $E(\bar{F}^{\alpha-1}(X)) = 1/\alpha$ , (4.1) is easily obtained.

For  $0 < \alpha < 1/2$ , the inequality

$$\frac{E(r^{2\alpha-2}(X))}{2\alpha - 1} < \frac{E^2(r^{\alpha-1}(X))}{\alpha^2}$$

is established and the first inequality of (4.2) is proved.

We know that  $E(r^{2\alpha-2}(X)) \geq E^2(r^{\alpha-1}(X))$  and  $1/(2\alpha - 1) > 1/\alpha^2$  for all  $\alpha > 1/2$ . Hence

$$\frac{E(r^{2\alpha-2}(X))}{2\alpha - 1} > \frac{E^2(r^{\alpha-1}(X))}{\alpha^2}$$

and the second inequality of (4.2) is obtained. It is easy to see that if  $F$  has an *IFR* distribution, then  $r(x)$  is an increasing function of  $x$ , and because  $\bar{F}$  is decreasing, the covariance is negative and the first inequality of (4.3) holds. The second inequality is similarly obtained.  $\square$

**Corollary 5.** *Let  $X$  be a nonnegative continuous random variable and let  $\mu(x)$  be the reversed hazard rate function of it, then*

- (a)  $TVE(X, \alpha) = \frac{1}{(1 - \alpha)^2} \left\{ \text{Cov}(\mu^{2\alpha-2}(X), F^{2\alpha-2}(X)) + \frac{E(\mu^{2\alpha-2}(X))}{2\alpha - 1} - \frac{E^2(\mu^{\alpha-1}(X))}{\alpha^2} \right\}$ ,
- (b)  $TVE(X, \alpha) < (>) \frac{1}{(1 - \alpha)^2} \left\{ \text{Cov}(\mu^{2\alpha-2}(X), F^{2\alpha-2}(X)) \right\}$ , if  $0 < \alpha < \frac{1}{2}$  ( $\alpha > \frac{1}{2}$ ),
- (c)  $TVE(X, \alpha) > (<) \frac{1}{(1 - \alpha)^2} \left\{ \frac{E(\mu^{2\alpha-2}(X))}{2\alpha - 1} - \frac{E^2(\mu^{\alpha-1}(X))}{\alpha^2} \right\}$ , if  $F$  is *IRFR(DRFR)*.

In the survival analysis and reliability engineering, we usually know the system's age. Hence (2.1) is not suitable in such a situation. The random variables  $\{X - t|X \geq t\}$ ,  $\{t - X|X \leq t\}$  and  $\{X|t_1 \leq X \leq t_2\}$  are indicative residual, past and double truncated (interval) lifetime of the system. If  $f$  and  $\bar{F}$  are density function and survival function of  $X$ , respectively, then the residual, past and interval lifetime density functions at the time  $t$  are as follows:

$$g_R(x, t) = \frac{f(x)}{\bar{F}(t)}, \quad x \geq t,$$

$$g_P(x, t) = \frac{f(x)}{F(t)}, \quad x \leq t,$$

$$g_I(x, t_1, t_2) = \frac{f(x)}{F(t_2) - F(t_1)}, \quad t_1 \leq x \leq t_2.$$

Also dynamic Tsallis entropy of  $X$  for the residual, past and double truncated lifetime random variables are defined as

$$I_{T_R}(X, \alpha, t) = \frac{1}{1 - \alpha} \left[ \frac{\int_t^\infty f^\alpha(x) dx}{\bar{F}^\alpha(t)} - 1 \right], \quad \alpha > 0, \quad \alpha \neq 1,$$

$$I_{T_P}(X, \alpha, t) = \frac{1}{1 - \alpha} \left[ \frac{\int_0^t f^\alpha(x) dx}{F^\alpha(t)} - 1 \right], \quad \alpha > 0, \quad \alpha \neq 1,$$

$$I_{T_I}(X, \alpha, t_1, t_2) = \frac{1}{1 - \alpha} \left[ \frac{\int_{t_1}^{t_2} f^\alpha(x) dx}{(F(t_2) - F(t_1))^\alpha} - 1 \right], \quad \alpha > 0, \quad \alpha \neq 1.$$

**Definition 4.** *The residual, past and interval Tsallis Varentropy of nonnegative random variables  $\{X - t|X \geq t\}$ ,  $\{t - X|X \leq t\}$  and  $\{X|t_1 \leq X \leq t_2\}$  are defined as*

$$TVE_R(X, \alpha, t) = \frac{1}{(1 - \alpha)^2} \text{Var} \left( \left( \frac{f(X)}{\bar{F}(t)} \right)^{\alpha-1} | X \geq t \right) = \frac{\bar{F}^{2-2\alpha}(t)}{(1 - \alpha)^2} \text{Var} (f^{\alpha-1}(X) | X \geq t), \quad (4.5)$$

$$TVE_P(X, \alpha, t) = \frac{1}{(1 - \alpha)^2} \text{Var} \left( \left( \frac{f(X)}{F(t)} \right)^{\alpha-1} | X \leq t \right) = \frac{F^{2-2\alpha}(t)}{(1 - \alpha)^2} \text{Var} (f^{\alpha-1}(X) | X \leq t), \quad (4.6)$$

$$TVE_I(X, \alpha, t_1, t_2) = \frac{1}{(1 - \alpha)^2} \text{Var} \left( \left( \frac{f(X)}{F(t_2) - F(t_1)} \right)^{\alpha-1} | t_1 \leq X \leq t_2 \right)$$

$$= \frac{(F(t_2) - F(t_1))^{2-2\alpha}}{(1 - \alpha)^2} \text{Var} (f^{\alpha-1}(X) | t_1 \leq X \leq t_2). \quad (4.7)$$

It is clear that when  $t \rightarrow 0$  ( $t \rightarrow \infty$ ),  $TVE_R(X, \alpha, t)$  ( $TVE_P(X, \alpha, t)$ ) =  $TVE(X, \alpha)$  and if  $t_1 \rightarrow 0$ ,  $t_2 \rightarrow \infty$ , then  $TVE_I(X, t_1, t_2) = TVE(X, \alpha)$ . For example, if  $X$  has a Pareto distribution with density function

$$f(x) = \frac{\theta\beta^\theta}{x^{\theta+1}}, \quad x > \beta, \quad \beta > 0, \quad \theta > 0, \quad \bar{F}(t) = \frac{\beta^\theta}{t^\theta},$$

then

$$TVE_R(X, \alpha, t) = \frac{t^{\theta(2\alpha-2)}\theta^{2\alpha-2}}{(1-\alpha)^2} \text{Var}(X^{(\theta+1)(1-\alpha)}|X \geq t),$$

$$TVE_R(X, \alpha, t) = \frac{t^{2-2\alpha}\theta^{2\alpha}}{(1-\alpha)^2} \left\{ \frac{-1}{\theta(\theta+1)(1-2\alpha)+\theta} + \frac{1}{[-\alpha(\theta+1)+1]^2} \right\}.$$

If  $\alpha \rightarrow 1$ , then the Tsallis residual varentropy reduces to the residual varentropy of Pareto distribution. It is  $(\theta+1)^2/\theta^2$  for all  $t > 0$ , and that is independent of the age of systems, but the Tsallis residual varentropy is not.

**Theorem 9.**  $X$  has a uniform distribution if and only if  $TVE_R(X, \alpha, t) = 0$ ,  $TVE_P(X, \alpha, t) = 0$ , or  $TVE_I(X, t_1, t_2) = 0$ .

*P r o o f.* If  $X \sim U(a, b)$ , then

$$TVE_R(X, \alpha, t) = \frac{\bar{F}^{2-2\alpha}(t)}{(1-\alpha)^2} \text{Var}((b-a)^{1-\alpha}|X \geq t) = 0.$$

On the other hand if  $TVE_R(X, \alpha, t) = 0$ , then

$$\frac{\bar{F}^{2-2\alpha}(t)}{(1-\alpha)^2} \text{Var}(f(X)^{\alpha-1}|X \geq t) = 0$$

and  $f(X)$  is almost surely constant. Similar to Theorem 1,  $X$  has the uniform distribution. For the other two cases, the proof is the same.  $\square$

**Proposition 2.** If  $X$  has an exponential distribution, then the Tsallis residual varentropy is independent of lifetime of systems.

*P r o o f.* In the exponential case, we know

$$g_R(x, t) = \frac{f(x+t)}{\bar{F}(t)} = \theta e^{-\theta x}, \quad x > 0.$$

Therefore the residual lifetime distribution is independent of  $t$  and  $g_R(x, t) = f(x)$  and  $TVE_R(X, \alpha, t) = TVE(X, \alpha)$ .  $\square$

We can introduce two new classes of distributions using the following definition.

**Definition 5.** We say that  $\bar{F}$  has an increasing (decreasing) Tsallis residual varentropy  $ITRVE$  ( $DTRVE$ ) if  $TVE_R(X, \alpha, t)$  is an increasing (decreasing) function of  $t$ , and  $F$  has an increasing (decreasing) Tsallis past varentropy  $ITPVE$  ( $DTPVE$ ) if  $TVE_P(X, \alpha, t)$  is an increasing (decreasing) function of  $t$  for all  $t \geq 0$ .

**Theorem 10.**  $\bar{F}(F)$  has  $DTRVE$  ( $ITPVE$ ) in  $t \geq 0$  if  $TVE_R(X, \alpha, t)$  ( $TVE_P(X, \alpha, t)$ )  $< \infty$ ,  $I_{T_R}(X, \alpha, t)$  ( $I_{T_P}(X, \alpha, t)$ )  $< \infty$ , and  $0 < \alpha \leq 1/2$ .

**P r o o f.** Using the differentiation of (4.5) and (4.6) with respect to  $t$ , we have

$$(1 - \alpha)^2 TVE'_R(X, \alpha, t) = r(t) \{ (2\alpha - 1)(1 - \alpha)^2 TVE_R(X, \alpha, t) - [(1 - \alpha)I_{T_R}(X, \alpha, t) + 1 - r^{\alpha-1}(t)]^2 \}, \quad (4.8)$$

$$(1 - \alpha)^2 TVE'_P(X, \alpha, t) = \mu(t) \{ (1 - 2\alpha)(1 - \alpha)^2 TVE_P(X, \alpha, t) + [\mu^{\alpha-1}(t) - (1 - \alpha)I_{T_P}(X, \alpha, t) - 1]^2 \}, \quad (4.9)$$

where  $I_{T_R}(X, \alpha, t)$  and  $I_{T_P}(X, \alpha, t)$  are the Tsallis residual and past entropy of  $X$  respectively. We see that if  $0 < \alpha \leq 1/2$  then  $TVE'_R(X, \alpha, t)$  ( $TVE'_P(X, \alpha, t)$ )  $\leq$  ( $\geq$ )  $0$  and  $\bar{F}(F)$  has  $DTRVE(ITPVE)$ .  $\square$

**Theorem 11.**  $\bar{F}$  has  $ITRVE(DTRVE)$  in  $t \geq 0$  if  $TVE_R(X, \alpha, t) < \infty$ ,  $I_{T_R}(X, \alpha, t) < \infty$ , and for all  $\alpha > 1/2$ ,

$$(2\alpha - 1)(1 - \alpha)^2 TVE_R(X, \alpha, t) \geq (\leq) [(1 - \alpha)I_{T_R}(X, \alpha, t) + 1 - r^{\alpha-1}(t)]^2.$$

Also  $F$  has  $DTPVE(ITPVE)$  in  $t \geq 0$  if  $TVE_P(X, \alpha, t) < \infty$ ,  $I_{T_P}(X, \alpha, t) < \infty$ , and for all  $\alpha > 1/2$ ,

$$|1 - 2\alpha|(1 - \alpha)^2 TVE_P(X, \alpha, t) \geq (\leq) [\mu^{\alpha-1}(t) - (1 - \alpha)I_{T_P}(X, \alpha, t) - 1]^2. \quad (4.10)$$

**P r o o f.** In Definition 5  $\bar{F}$  has  $ITRVE(DTRVE)$  in  $t$  if  $TVE'_R(X, \alpha, t) \geq (\leq) 0$ . By using (4.8), the proof is completed. Also (4.10) can be similarly proved by using (4.9).  $\square$

**Corollary 6.** If  $\bar{F}$  has  $ITRVE(DTRVE)$  in  $t \geq 0$ , then for all  $\alpha > 1/2$

$$TVE(X, \alpha) \geq (\leq) \frac{[(1 - \alpha)I_T(X, \alpha) + 1 - f^{\alpha-1}(0)]^2}{(2\alpha - 1)(1 - \alpha)^2}. \quad (4.11)$$

And if  $F$  has  $DTPVE(ITPVE)$  in  $t \geq 0$ , then for all  $\alpha > 1/2$

$$TVE(X, \alpha) \geq (\leq) \frac{[f^{\alpha-1}(\infty) - (1 - \alpha)I_T(X, \alpha) - 1]^2}{|1 - 2\alpha|(1 - \alpha)^2}. \quad (4.12)$$

Therefore (4.11) and (4.12) are lower (upper) bound for Tsallis varentropy for all  $\alpha > 1/2$ .

**Corollary 7.** Let  $\bar{F}$  be both  $ITRVE(DTRVE)$ , so  $TVE'_R(X, \alpha, t) = 0$ . Then

$$(2\alpha - 1)(1 - \alpha)^2 TVE_R(X, \alpha, t) = [(1 - \alpha)I_{T_R}(X, \alpha, t) + 1 - r^{\alpha-1}(t)]^2, \quad \alpha > 1/2,$$

and

$$TVE(X, \alpha) = \frac{[(1 - \alpha)I_T(X, \alpha) + 1 - f^{\alpha-1}(0)]^2}{(2\alpha - 1)(1 - \alpha)^2}, \quad \alpha > \frac{1}{2}, \quad (4.13)$$

and if  $F$  is both  $ITPVE(DTPVE)$ , then  $TVE'_P(X, \alpha, t) = 0$  and we have

$$|1 - 2\alpha|(1 - \alpha)^2 TVE_P(X, \alpha, t) = [\mu^{\alpha-1}(t) - (1 - \alpha)I_{T_P}(X, \alpha, t) - 1]^2,$$

therefore

$$TVE(X, \alpha) = \frac{[f^{\alpha-1}(\infty) - (1 - \alpha)I_T(X, \alpha) - 1]^2}{|1 - 2\alpha|(1 - \alpha)^2}, \quad \alpha > \frac{1}{2}. \quad (4.14)$$

Therefore (4.13) and (4.14) introduce the Tsallis varentropy when system's age is ineffective on it.



## 5. Conclusion

In this paper, we introduced the generalized varentropy of order  $\alpha$  for continuous random variables based on the Tsallis entropy. We showed that unlike the varentropy, which is a location and scale-invariant measure, the Tsallis varentropy is invariant to the location transformation but is not invariant to scale translate, unless when  $\alpha \rightarrow 1$ . After presenting some theorems of the properties of the Tsallis varentropy, we investigated them in the order statistics, which can be useful for the system designers in the lifetime information for the  $(n - i + 1)$ -out-of- $n$  systems. Also we studied them for the lifetime distributions and obtained some bounds for them by using the hazard and reversed hazard rate functions. Then we studied the age of systems regarding residual lifetime distributions and showed that in the uniform and exponential distributions, Tsallis residual varentropy is independent of the age of systems. We introduced two new classes of distributions by using the residual and past Tsallis varentropy, and we described some its properties.

## Acknowledgements

The authors would like to thank the editor and anonymous referees for their valuable comments and suggestions that improved the quality of the paper.

## REFERENCES

1. Abbasnejad M., Arghami N.R. Renyi entropy properties of order statistics. *Comm. Statist. Theory Methods*, 2010. Vol. 40, No. 1. P. 40–52. DOI: [10.1080/03610920903353683](https://doi.org/10.1080/03610920903353683)
2. Afhami B., Madadi M., Rezapour M. Goodness-of-fit test based on Shannon entropy of  $k$ -record values from the generalized. *J. Stat. Sci.*, 2015. Vol. 9, No. 1. P. 43–60.
3. Arikan E. Varentropy decreases under the polar transform. *IEEE Trans. Inform. Theory*, 2016. Vol. 62, No. 6. P. 3390–3400. DOI: [10.1109/TIT.2016.2555841](https://doi.org/10.1109/TIT.2016.2555841)
4. Arnold B. C., Balakrishnan N., Nagaraja H. N. *A First Course in Order Statistics*. Classics Appl. Math., vol. 54. Philadelphia: SIAM, 2008. 279 p. DOI: [10.1137/1.9780898719062](https://doi.org/10.1137/1.9780898719062)
5. Baratpour S., Ahmadi J., Arghami N.R. Characterizations based on Rényi entropy of order statistics and record values. *J. Statist. Plann. Inference*, 2008. Vol. 138, No. 8. P. 2544–2551. DOI: [10.1016/j.jspi.2007.10.024](https://doi.org/10.1016/j.jspi.2007.10.024)
6. Baratpour S., Khammar A. Tsallis entropy properties of order statistics and some stochastic comparisons. *J. Statist. Res. Iran*, 2016. Vol. 13, No. 1. P. 25–41. DOI: [10.18869/acadpub.jsri.13.1.2](https://doi.org/10.18869/acadpub.jsri.13.1.2)
7. Bobkov S., Madiman M. Concentration of the information in data with log-concave distributions. *Ann. Probab.*, 2011. Vol. 39, No. 4. P. 1528–1543. URL: <https://projecteuclid.org/euclid.aop/1312555807>
8. David H. A., Nagaraja H. N. *Order Statistics*. 3rd edition. Wiley Ser. Probab. Stat. Hoboken, New Jersey: John Wiley & Sons, Inc. 2003. 458 p. DOI: [10.1002/0471722162](https://doi.org/10.1002/0471722162)
9. Di Crescenzo A., Longobardi M. Statistic comparisons of cumulative entropies. In: *Stochastic Orders in Reliability and Risk. Li H., Li X. (eds.)*. Lect. Notes Stat., vol. 208. New York: Springer, 2013. P. 167–182. DOI: [10.1007/978-1-4614-6892-9\\_8](https://doi.org/10.1007/978-1-4614-6892-9_8)
10. Di Crescenzo A., Paolillo L. Analysis and applications of the residual varentropy of random lifetimes. *Probab. Engrg. Inform. Sci.*, 2020. P. 1–19. DOI: [10.1017/S0269964820000133](https://doi.org/10.1017/S0269964820000133)
11. Ebrahimi N., Kirmani S.N.U.A. Some results on ordering of survival functions through uncertainty. *Statist. Probab. Lett.*, 1996. Vol. 29, No. 2. P. 167–176. DOI: [10.1016/0167-7152\(95\)00170-0](https://doi.org/10.1016/0167-7152(95)00170-0)
12. Ebrahimi N., Soofi E. S., Zahedi H. Information properties of order statistics and spacing. *IEEE Trans. Inform. Theory*, 2004. Vol. 50, No. 1. P. 177–183. DOI: [10.1109/TIT.2003.821973](https://doi.org/10.1109/TIT.2003.821973)
13. Enomoto R., Okamoto N., Seo T. On the asymptotic normality of test statistics using Song's kurtosis. *J. Stat. Theory Pract.*, 2013. Vol. 7, No. 1. P. 102–119. DOI: [10.1080/15598608.2013.756351](https://doi.org/10.1080/15598608.2013.756351)
14. Gupta R. C., Taneja H. C., Thapliyal R. Stochastic comparisons based on residual entropy of order statistics and some characterization results. *J. Stat. Theory Appl.*, 2014. Vol. 13, No. 1. P. 27–37. DOI: [10.2991/jsta.2014.13.1.3](https://doi.org/10.2991/jsta.2014.13.1.3)

15. Kontoyiannis I., Verdú S. Optimal lossless compression: Source varentropy and dispersion. *IEEE Trans. Inform. Theory*, 2014. Vol. 60, No. 2. P. 777–795. DOI: [10.1109/TIT.2013.2291007](https://doi.org/10.1109/TIT.2013.2291007)
16. Liu J. *Information Theoretic Content and Probability*. Ph.D. Thesis, University of Florida, 2007.
17. Nanda A. K., Paul P. Some results on generalized residual entropy. *Inform. Sci.*, 2006. Vol. 176, No. 1. P. 27–47. DOI: [10.1016/j.ins.2004.10.008](https://doi.org/10.1016/j.ins.2004.10.008)
18. Park S. The entropy of consecutive order statistics. *IEEE Trans. Inform. Theory*, 1995. Vol. 41, No. 6. P. 2003–2007. DOI: [10.1109/18.476325](https://doi.org/10.1109/18.476325)
19. Psarrakos G., Navarro J. Generalized cumulative residual entropy and record values. *Metrika*, 2013. Vol. 76. P. 623–640. DOI: [10.1007/s00184-012-0408-6](https://doi.org/10.1007/s00184-012-0408-6)
20. Raqab M. Z., Amin W. A. Some ordering result on order statistics and record values. *IAPQR Trans.*, 1996. Vol. 21, No. 1. P. 1–8.
21. Shannon C. E. A mathematical theory of communication. *Bell System Technical J.*, 1948. Vol. 27, No. 3. P. 379–423 DOI: [10.1002/j.1538-7305.1948.tb01338.x](https://doi.org/10.1002/j.1538-7305.1948.tb01338.x)
22. Song K.-S. Rényi information, log likelihood and an intrinsic distribution measure. *J. Statist. Plann. Inference*, 2001. Vol. 93, No. 1–2. P. 51–69. DOI: [10.1016/S0378-3758\(00\)00169-5](https://doi.org/10.1016/S0378-3758(00)00169-5)
23. Tsallis C. Possible generalization of Boltzmann–Gibbs statistics. *J. Stat. Phys.*, 1988. Vol. 52. P. 479–487. DOI: [10.1007/BF01016429](https://doi.org/10.1007/BF01016429)
24. Vikas Kumar, Taneja H. C. A generalized entropy-based residual lifetime distributions. *Int. J. Biomath.*, 2011. Vol. 04, No. 02. P. 171–148. DOI: [10.1142/S1793524511001416](https://doi.org/10.1142/S1793524511001416)
25. Wilk G., Włodarczyk Z. Example of a possible interpretation of Tsallis entropy. *Phys. A: Stat. Mech. Appl.*, 2008. Vol. 387, No. 19–20. P. 4809–4813. DOI: [10.1016/j.physa.2008.04.022](https://doi.org/10.1016/j.physa.2008.04.022)
26. Wong K. M., Chen S. The entropy of ordered sequences and order statistics. *IEEE Trans. Inform. Theory*, 1990. Vol. 36, No. 2. P. 276–284. DOI: [10.1109/18.52473](https://doi.org/10.1109/18.52473)
27. Zarezadeh S., Asadi M. Results on residual Rényi entropy of order statistics and record values. *Inform. Sci.*, 2010. Vol. 180, No. 21. P. 4195–4206. DOI: [10.1016/j.ins.2010.06.019](https://doi.org/10.1016/j.ins.2010.06.019)
28. Zhang Z. Uniform estimates on the Tsallis entropies. *Lett. Math. Phys.*, 2007. Vol. 80. P. 171–181. DOI: [10.1007/s11005-007-0155-1](https://doi.org/10.1007/s11005-007-0155-1)
29. Zografos K. On Mardia’s and Song’s measures of kurtosis in elliptical distributions. *J. Multivariate Anal.*, 2008. Vol. 99, No. 5. P. 858–879. DOI: [10.1016/j.jmva.2007.05.001](https://doi.org/10.1016/j.jmva.2007.05.001)

## THE DYNAMIC DEFORMATION OF THREE-COMPONENT POROUS MEDIA

Victor S. Polenov<sup>1</sup>, Lyubov A. Kukarskikh<sup>2</sup>, Dmitry A. Nitsak<sup>3</sup>

Air Force Academy named after Professor N. E. Zhukovsky and Y. A. Gagarin,  
54a Old Bolsheviks Str., Voronezh, 394064, Russia

<sup>1</sup>polenov.vrn@mail.ru, <sup>2</sup>kukarskih.liubov@yandex.ru, <sup>3</sup>dima\_nitsak@mail.ru

**Abstract:** A mathematical model of the dynamic deformation of three-component elastic media saturated with liquid and gas, given by elastic moduli and coefficients characterizing the porosity and compressibility of the liquid and gas, is considered. Formulas for determining the propagation velocity of monochromatic waves in ternary porous media are obtained. The existence of three longitudinal waves depends on the discriminant of a cubic equation and the velocity ratio.

**Keywords:** Elasticity, Medium, Fluid, Stress, Deformation, Displacement.

### 1. Introduction

There are a number of papers [1–3, 8, 10] devoted to the propagation of elastic waves in two-component porous media. Among these studies, papers of M. A. Biot [1–3] should be noted. He created the theory of elasticity and consolidation of a porous medium. This theory studies settlement under the influence of a load of a porous medium containing a viscous fluid.

Phase states, laws of thermodynamics of porous systems, and attempts to solve wave problems in porous materials and moist soils were considered by Ya. I. Phrenkel [6], J. V. Reznichenko [13], and Kh. A. Rakhmatulin [12]. The studies of these authors played a huge role in creating the classic Biot–Phrenkel model.

When solving a considerable number of applied problems arising in various areas of human activity (soil, porous sintered composition materials, building materials, etc.), one has to deal with a three-component media. The complexity of describing the effects of the interaction of components, heat transfer, and other related processes has led to the fact that until now the generally accepted models (elastic medium—liquid—gas) have not been fully developed. Therefore, a mathematical three-component model that takes into account the porosity of the medium is of apparent interest.

The paper considers the ratio of the velocities of acceleration waves in a three-component porous medium to the propagation velocities of the wave surface of the porous medium in the longitudinal and transverse directions. The interpenetrating motion of the elastic component, liquid and gas is perceived as the motion of liquid, and gas in a deformable porous medium. It is supposed that the pore size is small compared to the distance at which the kinematic and dynamic characteristics of the motion change significantly. This allows us to assume that all three media are continuous and that at each point in space there are three displacement vectors.

It is proved that, in such a medium, in the general case, three waves propagate, whose velocities essentially depend on the direction of propagation of the wave surface. Graphs of the dependence of the velocity ratio on the porosity of the medium are constructed.

## 2. Main results

Consider a system of equations determining the dynamic behavior of a three-component medium saturated with liquid and gas in the motion of the components [9]:

- complete stress tensor in the skeleton in the presence of liquid and gas in pores

$$T_{ij} = \lambda u_{k,k}^{(1)} \delta_{ij} + \mu (u_{i,j}^{(1)} + u_{j,i}^{(1)}) + \underline{m}R_0^{(2)} u_{k,k}^{(2)} \delta_{ij} + \underline{m}R_0^{(3)} u_{k,k}^{(3)} \delta_{ij}; \quad (2.1)$$

- forces acting on the liquid and gas per unit area of the cross section of the porous medium:

$$\begin{aligned} N &= \underline{m}R_0^{(2)} u_{k,k}^{(1)} + mR_0^{(2)} u_{k,k}^{(2)} + \underline{m}R_0^{(2)} u_{k,k}^{(3)}, \\ P &= \underline{m}R_0^{(3)} u_{k,k}^{(1)} + \underline{m}R_0^{(3)} u_{k,k}^{(2)} + mR_0^{(3)} u_{k,k}^{(3)}; \end{aligned} \quad (2.2)$$

- equations of motion of the porous media

$$\begin{aligned} \rho_{11} \ddot{u}_i^{(1)} + \rho_{12} \ddot{u}_i^{(2)} + \rho_{13} \ddot{u}_i^{(3)} &= T_{ij,j}, \\ \rho_{21} \ddot{u}_i^{(1)} + \rho_{22} \ddot{u}_i^{(2)} + \rho_{23} \ddot{u}_i^{(3)} &= N_{,i}, \\ \rho_{31} \ddot{u}_i^{(1)} + \rho_{32} \ddot{u}_i^{(2)} + \rho_{33} \ddot{u}_i^{(3)} &= P_{,i}. \end{aligned} \quad (2.3)$$

Here  $\lambda$  and  $\mu$  are the Lamé coefficients;  $u_i^{(\alpha)}$  are the component displacements, where  $\alpha = \overline{1,3}$  stands for the medium: 1 for the rigid component, 2 for the liquid, and 3 for the gas; the dots above the letters indicate the time derivatives; indices after the comma below the letter stand for the derivatives of the corresponding coordinates;  $\delta_{ij}$  is the Kronecker symbol;  $\rho_{11}$ ,  $\rho_{22}$ , and  $\rho_{33}$  are effective densities of the rigid component, liquid, and gas, respectively;  $\rho_{11} < 0$ ,  $\rho_{12} < 0$ , and  $\rho_{13} < 0$  are the coefficients of dynamic coupling of the skeleton, liquid, and gas, respectively;  $R_0^{(2)}$  and  $R_0^{(3)}$  are compressibility moduli of the components saturated with liquid and gas, respectively;  $0 \leq m \leq 1$  is the porosity of a medium,  $\underline{m} = 1 - m$ ; and  $i, j, k = \overline{1,3}$ . Suppose that  $\rho_{ij} = \rho_{ji}$ .

Hereinafter, the repeated indices assume a summation of one to three.

An acceleration wave in a three-component porous media saturated with a liquid and gas is an isolated surface on which the stress, the forces acting on the liquid and gas, and the propagation velocities of the components are continuous while some of their partial derivatives have discontinuities.

Differentiating relations (2.1) and (2.2) in  $t$ , we obtain

$$\begin{aligned} \dot{T}_{ij} &= \lambda v_{k,k}^{(1)} \delta_{ij} + \mu (v_{i,j}^{(1)} + v_{j,i}^{(1)}) + \underline{m}R_0^{(2)} v_{k,k}^{(2)} \delta_{ij} + \underline{m}R_0^{(3)} v_{k,k}^{(3)} \delta_{ij}, \\ \dot{N} &= \underline{m}R_0^{(2)} v_{k,k}^{(1)} + mR_0^{(2)} v_{k,k}^{(2)} + \underline{m}R_0^{(2)} v_{k,k}^{(3)}, \\ \dot{P} &= \underline{m}R_0^{(3)} v_{k,k}^{(1)} + \underline{m}R_0^{(3)} v_{k,k}^{(2)} + mR_0^{(3)} v_{k,k}^{(3)}. \end{aligned} \quad (2.4)$$

Let us write equations (2.3) and relations (2.4) in discontinuities [5, 7, 11, 14]:

$$\begin{aligned} \lambda [v_{k,k}^{(1)}] \delta_{ij} + \mu ([v_{i,j}^{(1)}] + [v_{j,i}^{(1)}]) + \underline{m}R_0^{(2)} [v_{k,k}^{(2)}] \delta_{ij} + \underline{m}R_0^{(3)} [v_{k,k}^{(3)}] \delta_{ij} &= [\dot{T}_{ij}], \\ \underline{m}R_0^{(2)} [v_{k,k}^{(1)}] + mR_0^{(2)} [v_{k,k}^{(2)}] + \underline{m}R_0^{(2)} [v_{k,k}^{(3)}] &= [\dot{N}], \\ \underline{m}R_0^{(3)} [v_{k,k}^{(1)}] + \underline{m}R_0^{(3)} [v_{k,k}^{(2)}] + mR_0^{(3)} [v_{k,k}^{(3)}] &= [\dot{P}], \\ \rho_{11} [\dot{v}_i^{(1)}] + \rho_{12} [\dot{v}_i^{(2)}] + \rho_{13} [\dot{v}_i^{(3)}] &= [T_{ij,j}], \\ \rho_{21} [\dot{v}_i^{(1)}] + \rho_{22} [\dot{v}_i^{(2)}] + \rho_{23} [\dot{v}_i^{(3)}] &= [N_{,i}], \\ \rho_{31} [\dot{v}_i^{(1)}] + \rho_{32} [\dot{v}_i^{(2)}] + \rho_{33} [\dot{v}_i^{(3)}] &= [P_{,i}], \end{aligned} \quad (2.5)$$

where  $[\cdot]$  denotes the difference in the values of a function on different sides of the discontinuity surface.

We apply kinematic and geometric consistency conditions of first-order to relations (2.5) on the discontinuity surface:

$$\begin{aligned} [T_{ik,k}] &= s_{ik}\nu_k, [\dot{T}_{ik}] = -s_{ik}G, [N_{,k}] = \eta\nu_k, [\dot{N}] = -\eta G, \\ [P_{,i}] &= \gamma\nu_i, [\dot{P}] = -\gamma G, [v_{,i,k}^{(\alpha)}] = \lambda_i^{(\alpha)}\nu_k, [\dot{v}_i^{(\alpha)}] = -\lambda_i^{(\alpha)}G. \end{aligned} \quad (2.6)$$

Here  $s_{ik}$ ,  $\eta$ ,  $\gamma$ , and  $\lambda_i^{(\alpha)}$  are values characterizing jumps of the first derivatives of stresses, forces acting on the liquid and gas, and the propagation velocities of the components;  $\nu_i$  are the components of the unit normal to the wave surface; and  $G$  is the propagation velocity of the wave surface of the porous medium.

Using conditions (2.6), we write formulas (2.5) in the form

$$\begin{aligned} \lambda\lambda_k^{(1)}\nu_k\delta_{ij} + \mu(\lambda_i^{(1)}\nu_j + \lambda_j^{(1)}\nu_i) + \underline{m}R_0^{(2)}\lambda_k^{(2)}\nu_k\delta_{ij} + \underline{m}R_0^{(3)}\lambda_k^{(3)}\nu_k\delta_{ij} &= -s_{ij}G, \\ \underline{m}R_0^{(2)}\lambda_k^{(1)}\nu_k + mR_0^{(2)}\lambda_k^{(2)}\nu_k + \underline{m}R_0^{(2)}\lambda_k^{(3)}\nu_k &= -\eta G, \\ \underline{m}R_0^{(3)}\lambda_k^{(1)}\nu_k + \underline{m}R_0^{(3)}\lambda_k^{(2)}\nu_k + mR_0^{(3)}\lambda_k^{(3)}\nu_k &= -\gamma G, \\ \rho_{11}\lambda_i^{(1)}G + \rho_{12}\lambda_i^{(2)}G + \rho_{13}\lambda_i^{(3)}G &= -s_{ij}\nu_j, \\ \rho_{12}\lambda_i^{(1)}G + \rho_{22}\lambda_i^{(2)}G + \rho_{23}\lambda_i^{(3)}G &= -\eta\nu_i, \\ \rho_{13}\lambda_i^{(1)}G + \rho_{23}\lambda_i^{(2)}G + \rho_{33}\lambda_i^{(3)}G &= -\gamma\nu_i. \end{aligned} \quad (2.7)$$

Excluding the values  $s_{ij}$ ,  $\eta$ , and  $\gamma$  from (2.7), we get a homogeneous system for  $\lambda_k^{(1)}$ ,  $\lambda_k^{(2)}$ , and  $\lambda_k^{(3)}$ :

$$\begin{aligned} \lambda\lambda_k^{(1)}\nu_k\nu_i + \mu(\lambda_i^{(1)} + \lambda_j^{(1)}\nu_i\nu_j) + \underline{m}R_0^{(2)}\lambda_k^{(2)}\nu_k\nu_i + \underline{m}R_0^{(3)}\lambda_k^{(3)}\nu_k\nu_i &= \\ = \rho_{11}G^2\lambda_i^{(1)} + \rho_{12}G^2\lambda_i^{(2)} + \rho_{13}G^2\lambda_i^{(3)}, \\ \underline{m}R_0^{(2)}\lambda_k^{(1)}\nu_k\nu_i + mR_0^{(2)}\lambda_k^{(2)}\nu_k\nu_i + \underline{m}R_0^{(2)}\lambda_k^{(3)}\nu_k\nu_i &= \\ = \rho_{12}G^2\lambda_i^{(1)} + \rho_{22}G^2\lambda_i^{(2)} + \rho_{23}G^2\lambda_i^{(3)}, \\ \underline{m}R_0^{(3)}\lambda_k^{(1)}\nu_k\nu_i + \underline{m}R_0^{(3)}\lambda_k^{(2)}\nu_k\nu_i + mR_0^{(3)}\lambda_k^{(3)}\nu_k\nu_i &= \\ = \rho_{13}G^2\lambda_i^{(1)} + \rho_{23}G^2\lambda_i^{(2)} + \rho_{33}G^2\lambda_i^{(3)}. \end{aligned} \quad (2.8)$$

Similar to [8], system (2.8) enables deriving formulas for determining the velocity of longitudinal and transverse waves in the three-component porous media.

We find propagation velocities of longitudinal waves assuming that  $\lambda_k^{(\alpha)}\nu_k \neq 0$  on the wave surface. Reducing (2.8) by  $\nu_i$  and summing over the repeated index  $i$ , we obtain the homogeneous system of three linear equations for  $\omega_\alpha = \lambda_i^{(\alpha)}\nu_i$ :

$$\begin{aligned} (\Lambda - \rho_{11}G_l^2)\omega_1 + (\underline{m}R_0^{(2)} - \rho_{12}G_l^2)\omega_2 + (\underline{m}R_0^{(3)} - \rho_{13}G_l^2)\omega_3 &= 0, \\ (\underline{m}R_0^{(2)} - \rho_{12}G_l^2)\omega_1 + (mR_0^{(2)} - \rho_{22}G_l^2)\omega_2 + (\underline{m}R_0^{(2)} - \rho_{23}G_l^2)\omega_3 &= 0, \\ (\underline{m}R_0^{(3)} - \rho_{13}G_l^2)\omega_1 + (\underline{m}R_0^{(3)} - \rho_{23}G_l^2)\omega_2 + (mR_0^{(3)} - \rho_{33}G_l^2)\omega_3 &= 0, \end{aligned} \quad (2.9)$$

where  $\Lambda = \lambda + 2\mu$ .

Define

$$\begin{aligned}
\sigma_{11} &= \frac{\Lambda}{M}, & \sigma_{22} &= \frac{mR_0^{(2)}}{M}, & \sigma_{33} &= \frac{mR_0^{(3)}}{M}, \\
\sigma_{12} = \sigma_{21} = \sigma_{23} &= \frac{mR_0^{(2)}}{M}, & \sigma_{13} = \sigma_{31} = \sigma_{32} &= \frac{mR_0^{(3)}}{M}, \\
M &= \Lambda + mR_0^{(2)} + mR_0^{(3)} + 3mR_0^{(2)} + 3mR_0^{(3)}; \\
\gamma_{ij} &= \frac{\rho_{ij}}{\rho}, & \rho &= \sum_i \rho_{ii} + 2 \sum_{\substack{i,j;i \neq j; \\ i < j}} \rho_{ij}.
\end{aligned} \tag{2.10}$$

Taking into account (2.10), we write system (2.9) in the dimensionless matrix form:

$$(\Sigma z_l^2 - \Gamma) \vec{\omega} = \mathbf{0}, \Sigma = \{\sigma_{ij}\}, \Gamma = \{\gamma_{ij}\}, \vec{\omega} = \{\omega_i\}, \tag{2.11}$$

where  $z_l^2 = c_l^2/G_l^2$ ,  $c_l^2 = M/\rho$ ;  $c_l$  are the propagation velocities of the longitudinal waves in the porous media;  $G_l$  is the longitudinal component of the propagation velocity the wave surface in the porous medium; and  $z_l$  is the longitudinal velocity ratio.

The condition for system (2.11), homogeneous with respect to  $\omega_1$ ,  $\omega_2$ , and  $\omega_3$ , to have a non-trivial solution is that its third order determinant must be zero:

$$|\Sigma z_l^2 - \Gamma| = 0. \tag{2.12}$$

It is shown in what follows that condition (2.12) also defines three propagation velocities of the wave surface in the three-component porous medium.

Expanding the determinant (2.12), we obtain a cubic equation for  $z_l^2$ :

$$kz_l^6 + bz_l^4 + dz_l^2 + f = 0, \tag{2.13}$$

where

$$\begin{aligned}
k &= \sigma_{11}(\sigma_{22}\sigma_{33} - \sigma_{12}\sigma_{13}) + \sigma_{12}^2(\sigma_{13} - \sigma_{33}) + \sigma_{13}^2(\sigma_{12} - \sigma_{22}), \\
b &= \gamma_{11}(\sigma_{12}\sigma_{13} - \sigma_{22}\sigma_{33}) + \gamma_{22}(\sigma_{13}^2 - \sigma_{11}\sigma_{33}) + \gamma_{33}(\sigma_{12}^2 - \sigma_{11}\sigma_{22}) - \\
&\quad - \gamma_{12}(\sigma_{13}^2 + \sigma_{12}\sigma_{13} - 2\sigma_{12}\sigma_{33}) - \gamma_{13}(\sigma_{12}^2 + \sigma_{12}\sigma_{13} - 2\sigma_{13}\sigma_{22}) + \gamma_{23}[\sigma_{11}(\sigma_{12} + \sigma_{13}) - 2\sigma_{12}\sigma_{13}], \\
d &= -\sigma_{11}(\gamma_{23}^2 - \gamma_{22}\gamma_{33}) - \sigma_{22}(\gamma_{13}^2 - \gamma_{11}\gamma_{33}) - \sigma_{33}(\gamma_{12}^2 - \gamma_{11}\gamma_{22}) - \\
&\quad - 2\sigma_{12}(\gamma_{12}\gamma_{33} - \gamma_{13}\gamma_{23}) - 2\sigma_{13}(\gamma_{13}\gamma_{22} - \gamma_{12}\gamma_{23}) + (\sigma_{12} + \sigma_{13})(\gamma_{12}\gamma_{13} - \gamma_{11}\gamma_{23}), \\
f &= -(\gamma_{11}\gamma_{22}\gamma_{33} + 2\gamma_{12}\gamma_{13}\gamma_{23} - \gamma_{11}\gamma_{23}^2 - \gamma_{22}\gamma_{13}^2 - \gamma_{33}\gamma_{12}^2).
\end{aligned}$$

We find the solution of the cubic equation (2.13) by the Cardano formulas [4]. Divide (2.13) by  $k$  and introduce a new variable

$$y = z_l^2 + \frac{b}{3k}.$$

On rearrangement, we get

$$y^3 + 3py + 2q = 0, \tag{2.14}$$

where

$$3p = \frac{d}{k} - \frac{1}{3} \left( \frac{b}{k} \right)^2, \quad 2q = 2 \left( \frac{b}{3k} \right)^3 - \frac{bd}{3k^2} + \frac{f}{k}.$$

Let us calculate the discriminant  $D = p^3 + q^2$ . If  $D < 0$ , then (2.14) has three distinct real roots expressed in terms of complex values. If  $D > 0$ , then (2.14) has one real and two imaginary solutions. If  $D = 0$ , then there are three real solutions, two of which coincide.

Thus, in the considered three-component porous medium, there are three types of longitudinal waves can propagate depending on the discriminant of the cubic equation (2.14) and the velocity ratios  $z_l^{(\alpha)}$ .

Knowing the propagation velocities  $c_l$  of the longitudinal waves and the velocity ratios  $z_l$ , we can calculate the propagation velocity of the longitudinal wave surface in the three-component porous media by the formula  $G_l^{(\alpha)} = c_l/z_l^{(\alpha)}$ .

In the absence of coupling between the liquid—gas and elasticity—gas components, i.e., if  $\gamma_{13} = 0$ ,  $\gamma_{23} = 0$ ,  $\sigma_{13} = 0$ , and  $\sigma_{32} = 0$ , then equation (2.13) takes the form of biquadratic equation with respect to  $z_t^2$ :

$$k_1 z_t^4 + b_1 z_t^2 + d_1 = 0, \quad (2.15)$$

where

$$k_1 = \sigma_{11}\sigma_{22} - \sigma_{12}^2, \quad b_1 = 2\sigma_{12}\gamma_{12} - \sigma_{11}\gamma_{22} - \sigma_{22}\gamma_{11}, \quad d_1 = \gamma_{11}\gamma_{22} - \gamma_{12}^2.$$

Equation (2.15) coincides with the equation from [8].

Assume that  $\lambda_i^{(\alpha)} \nu_i = 0$  in (2.8). Under the condition  $G = G_t$ , we obtain in the dimensionless form

$$\begin{aligned} (\sigma'_{11} z_t^2 - \gamma_{11})\omega_1 - \gamma_{12}\omega_2 - \gamma_{13}\omega_3 &= 0, \\ \gamma_{12}\omega_1 + \gamma_{22}\omega_2 + \gamma_{23}\omega_3 &= 0, \\ \gamma_{13}\omega_1 + \gamma_{23}\omega_2 + \gamma_{33}\omega_3 &= 0; \\ \sigma'_{11} &= \mu/M', \quad M' = \mu + mR_0^{(2)} + mR_0^{(3)} + 3\underline{m}R_0^{(2)} + 3\underline{m}R_0^{(3)}, \\ z_t^2 &= c_t^2/G_t^2, \quad c_t^2 = M'/\rho. \end{aligned} \quad (2.16)$$

For system (2.16) to have a nontrivial solution, its determinant must be zero.

Expanding the determinant

$$\begin{vmatrix} \sigma'_{11} z_t^2 - \gamma_{11} & -\gamma_{12} & -\gamma_{13} \\ \gamma_{12} & \gamma_{22} & \gamma_{23} \\ \gamma_{13} & \gamma_{23} & \gamma_{33} \end{vmatrix},$$

we obtain an expression for determining the ratio of the propagation velocities of the transverse waves in the three-component media:

$$z_t = \sqrt{\frac{\gamma_{11}\gamma_{22}\gamma_{33} + 2\gamma_{12}\gamma_{13}\gamma_{23} - \gamma_{11}\gamma_{23}^2 - \gamma_{22}\gamma_{13}^2 - \gamma_{33}\gamma_{12}^2}{\sigma'_{11}(\gamma_{22}\gamma_{33} - \gamma_{23}^2)}}. \quad (2.17)$$

In the absence of coupling between the liquid—gas and elastic—gas components, i.e., if  $\gamma_{23} = 0$  and  $\gamma_{13} = 0$ , then (2.17) yields

$$z_t = \sqrt{\frac{\gamma_{11}\gamma_{22} - \gamma_{12}^2}{\sigma'_{11}\gamma_{22}}}. \quad (2.18)$$

Formula (2.18) coincides with the formula obtained in [8].

### 3. Calculation results

The figure, using the data in the table, shows the dependencies of the ratio of the propagation velocity of longitudinal waves in the three-component medium to the propagation velocity of the wave surface in the longitudinal direction on the medium porosity.

Table 1. Input data for calculating  $z_l^{(\alpha)}$ 

$m$	$\sigma_{11}$	$\sigma_{22}$	$\sigma_{33}$	$\sigma_{12}$	$\sigma_{13}$	$\{\gamma_{ij}\}$
0.2	0.6	0.2	0.15	0.08	0.009	$\gamma_{11} = 0.7; \gamma_{22} = 0.32;$ $\gamma_{33} = 0.1; \gamma_{12} = \gamma_{13} =$ $= \gamma_{23} = -0.02$
0.4		0.15	0.1	0.025	0.025	
0.7		0.15	0.19	0.01	0.01	
0.9		0.1	0.15	0.025	0.025	

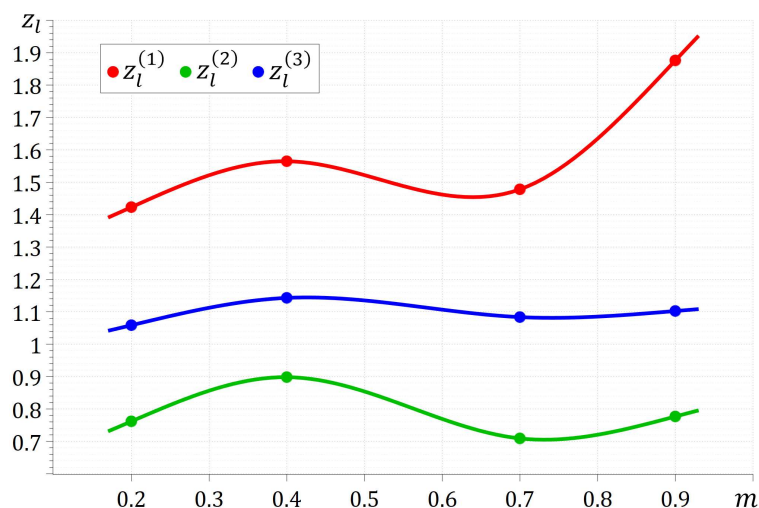

Figure 1. Velocity ratios in the three-component porous media

It is seen from the figure that the ratios  $z_l^{(1)}$  and  $z_l^{(2)}$  change from 1.4 to 1.9 and from 0.7 to 0.9, respectively. The ratio  $z_l^{(3)}$  demonstrates a weak dependence on the porosity and is close to 1.1. Thus, in the three-component porous media, the ratios of longitudinal velocities can take values both more and less than one.

#### 4. Conclusion

1. In the three-component porous media, three longitudinal and one transverse waves propagate whose velocities are defined by formulas (2.8) with  $\lambda_k^{(\alpha)} \nu_k \neq 0$  or  $\lambda_i^{(\alpha)} \nu_i = 0$ .
2. In general, ratios of the longitudinal velocity components in the three-component porous medium depend on the coefficients and discriminant of a cubic equation.

#### REFERENCES

1. Biot M. A. Theory of propagation of elastic waves in a fluid-saturated porous solid. I. Low-Frequency Range. *J. Acoust. Soc. America*, 1956. Vol. 28, No. 2. P. 168–178. DOI: [10.1121/1.1908239](https://doi.org/10.1121/1.1908239)
2. Biot M. A. Theory of propagation of elastic waves in a fluid-saturated porous solid. II. Higher Frequency Range. *J. Acoust. Soc. America*, 1956. Vol. 28, No. 2. P. 179–191. DOI: [10.1121/1.1908241](https://doi.org/10.1121/1.1908241)
3. Biot M. A. Mechanics of deformation and acoustic propagation in porous media. *J. Appl. Phys.*, 1962. Vol. 33, No. 4. P. 1483–1498.
4. Bronstein K. A., Semendyaev I. N. *Spravochnik po matematike dlya inzhenerov i uchashchihsya vtuzov* [Maths Reference for Engineers and University Students]. Moscow, 1964. 608 p. (in Russian)



5. Bykovtsev G. I., Verveiko N. D. O rasprostraneniі voln v uprugovyyazko-plasticheskoi crede [On the propagation of waves in an elastic-viscous-plastic medium]. *Izv. Ross. Akad. Nauk. Mekh. Tverd. Tela*, 1966. No. 4. P. 111–123. (In Russian)
6. Frenkel Ya. I. K teorii seysmicheskikh i seysmoelectricheskikh yavleniy vo vlazhnoi pochve [Toward a theory of seismic and seismoelectric phenomena in the moist soil]. *Izv. ANSSR. Ser. Geogr. Geophys.* [Proceedings of the SSR Academy of Sciences. The Series of Geography and Geophysics], 1944. Vol. 8. No. 4. P. 133–150. (in Russian)
7. Kukarskikh L. A., Polenov V. S. Advance of waves in fluid saturated elastic–viscoplastic porous medium. *Bull. Voronezh St. Tekh. Univ.*, 2012. Vol. 9, No. 8. P. 57–60. (in Russian)
8. Maslikova T. I., Polenov V. S. The propagation of unsteady elastic waves in homogeneous porous media. *Mech. Solids.*, 2005. Vol. 40, No. 1. P. 86–89.
9. Polenov V. S. Osnovnye uravneniya dinamicheskogo demphirovaniya trekhkomponentnykh sred [The basic equations of the dynamic deformation of three-component media]. *Sovremennye tendentsii razvitiya estestvoznaniya i tekhnicheskikh nauk: Sbornik nauchnykh trudov po materialam MNPK. Belgorod* [Modern trends in the development of natural sciences and technical sciences: A collection of scientific papers based on materials of the IPPC. Belgorod], 2018. P. 31–34. (in Russian)
10. Polenov V. S., Chigarev A. V. Mathematical modeling of shock waves in inhomogeneous viscoelastic two-component media. *Appl. Math. Phys.*, 2018. Vol. 6, No. 5. P. 997–1005. DOI: [10.4236/jamp.2018.65086](https://doi.org/10.4236/jamp.2018.65086)
11. Polenov V. S., Nitsak D. A. Matematicheskoe modelirovanie akusticheskoi emissii v nasychennykh zhidkostey dvukhkomponentnykh sredakh. In: *Proc. XI Int. Sci. Pract. Conf. "Science of Russia: goals and objectives". Part 2. Oct. 10, 2018, Ekaterinburg, Russia*. Ekaterinburg: NIC "L-ZHurnal", 2018. P. 52–58. DOI: [10.18411/sr-10-10-2018-33](https://doi.org/10.18411/sr-10-10-2018-33) (in Russian)
12. Rakhmatulin Kh. A. *Gazovaya i volnovaya dinamika* [Gas and Wave Dynamics]. M: MSU, 1983. 200 p. (in Russian)
13. Reznichenko Yu. V. O rasprostraneniі seysmicheskikh voln v discretnykh i heterogennykh sredakh [On the propagation of seismic waves in discrete and heterogeneous media]. *Izv. Akad. Nauk SSSR. Ser. Geogr. Geophys.*, 1949. Vol. 13. P. 115–128. (in Russian)
14. Thomas T. Y. *Plastic Flow and Fracture in Solids*. New York: Acad. Press, 1961. 267 p.

# ON GENERALIZED EIGHTH ORDER MOCK THETA FUNCTIONS

Pramod Kumar Rawat

University of Lucknow, Lucknow 226007, India

[pramodkrawat@yahoo.com](mailto:pramodkrawat@yahoo.com)

**Abstract:** In this paper we have generalized eighth order mock theta functions, recently introduced by Gordon and MacIntosh involving four independent variables. The idea of generalizing was to have four extra parameters, which on specializing give known functions and thus these results hold for those known functions. We have represented these generalized functions as  $q$ -integral. Thus on specializing we have the classical mock theta functions represented as  $q$ -integral. The same is true for the multibasic expansion given.

**Keywords:**  $q$ -Hypergeometric Series, Mock Theta functions, Continued Fractions,  $q$ -Integrals.

## 1. Introduction

The last gift to mathematics by Ramanujan was mock theta functions. In his last letter to Hardy [5], Ramanujan introduced 17 functions and called them mock theta functions as they were not theta functions and classified them as 4 functions of third order, 10 functions of fifth order and 3 functions of seventh order though Ramanujan did not say what he meant by “order” of mock theta function. Later Watson [12] introduced 3 more mock theta functions of third order. Gordon and McIntosh [7] gave eight more mock theta functions and called them of eighth order. Andrews and Hickerson [3] said the “order” is connected with combinatorics interpretation. Andrews [1] generalized five third order mock theta functions. Srivastava [11] generalized eighth order mock theta function. Recently Choi [4] also generalized mock theta functions of third, fifth, sixth, seventh and tenth order.

Motivated by Andrews’ generalization of five of seven third order mock theta functions and Choi’s generalization, we have tried to generalize the eighth order mock theta functions by introducing four independent variables. The advantage is that by specializing the parameters we can have known functions.

In this paper we have represented these generalized functions as  $q$ -integral and we have also given the multibasic expansion. Thus we have on specializing the parameters, the classical mock theta functions representation as  $q$ -integral and the multibasic expansion for generalized functions reduced to classical mock theta function of eighth order.

## 2. Definitions and notations

The eighth order mock theta functions of Gordon and McIntosh [7] are

$$S_0(q) = \sum_{n=0}^{\infty} \frac{q^{n^2}(-q; q^2)_n}{(-q^2; q^2)_n}, \quad S_1(q) = \sum_{n=0}^{\infty} \frac{q^{n(n+2)}(-q; q^2)_n}{(-q^2; q^2)_n},$$

$$T_0(q) = \sum_{n=0}^{\infty} \frac{q^{(n+1)(n+2)}(-q^2; q^2)_n}{(-q; q^2)_{n+1}}, \quad T_1(q) = \sum_{n=0}^{\infty} \frac{q^{n^2+n}(-q^2; q^2)_n}{(-q; q^2)_{n+1}},$$

$$\begin{aligned}
U_0(q) &= \sum_{n=0}^{\infty} \frac{q^{n^2}(-q; q^2)_n}{(-q^4; q^4)_n}, & U_1(q) &= \sum_{n=0}^{\infty} \frac{q^{(n+1)^2}(-q; q^2)_n}{(-q^2; q^4)_{n+1}}, \\
V_0(q) &= -1 + 2 \sum_{n=0}^{\infty} \frac{q^{n^2}(-q; q^2)_n}{(q; q^2)_n} = -1 + 2 \sum_{n=0}^{\infty} \frac{q^{2n^2}(-q^2; q^4)_n}{(q; q^2)_{2n+1}}, \\
V_1(q) &= \sum_{n=0}^{\infty} \frac{q^{(n+1)^2}(-q; q^2)_n}{(q; q^2)_{n+1}} = \sum_{n=0}^{\infty} \frac{q^{2n^2+2n+1}(-q^4; q^4)_n}{(q; q^2)_{2n+2}},
\end{aligned}$$

where

$$(a; q^k)_n = \prod_{j=1}^n (1 - aq^{k(j-1)}), \quad (a; q^k)_{\infty} = \prod_{j=1}^{\infty} (1 - aq^{k(j-1)}), \quad \text{and} \quad (a; q^k)_0 = 1.$$

### 3. Generalized eighth order mock theta functions

The four variable generalization of the eighth order mock theta functions are

$$\begin{aligned}
S_0(t, \alpha, \beta, z; q) &= \frac{1}{(t)_{\infty}} \sum_{n=0}^{\infty} \frac{(t)_n q^{n^2-n+n\beta} (-zq; q^2)_n \alpha^n}{(-\alpha q^2; q^2)_n}, \\
T_0(t, \alpha, \beta, z; q) &= \frac{1}{(t)_{\infty}} \sum_{n=0}^{\infty} \frac{(t)_n q^{n^2+3n+2-n+n\beta} (-q^2/\alpha; q^2)_n}{(-q/z; q^2)_{n+1} z^{n+1}}, \\
U_0(t, \alpha, \beta, z; q) &= \frac{1}{(t)_{\infty}} \sum_{n=0}^{\infty} \frac{(t)_n q^{n^2-n+n\beta} (-zq; q^2)_n \alpha^n}{(-\alpha q^4; q^4)_n}, \\
V_0(t, \alpha, \beta, z; q) &= -1 + \frac{1}{(t)_{\infty}} \sum_{n=0}^{\infty} \frac{(t)_n q^{n^2-n+n\beta} (-zq; q^2)_n \alpha^n}{(\alpha q; q^2)_n}, \\
S_1(t, \alpha, \beta, z; q) &= \frac{1}{(t)_{\infty}} \sum_{n=0}^{\infty} \frac{(t)_n q^{n^2+2n-n+n\beta} (-zq; q^2)_n \alpha^n}{(-\alpha q^2; q^2)_n}, \\
T_1(t, \alpha, \beta, z; q) &= \frac{1}{(t)_{\infty}} \sum_{n=0}^{\infty} \frac{(t)_n q^{n^2+n-n+n\beta} (-q^2/\alpha; q^2)_n}{(-q/z; q^2)_{n+1} z^{n+1}}, \\
U_1(t, \alpha, \beta, z; q) &= \frac{1}{(t)_{\infty}} \sum_{n=0}^{\infty} \frac{(t)_n q^{(n+1)^2-n+n\beta} (-zq; q^2)_n}{(-\alpha q^2; q^4)_{n+1}}, \\
V_1(t, \alpha, \beta, z; q) &= \frac{1}{(t)_{\infty}} \sum_{n=0}^{\infty} \frac{(t)_n q^{(n+1)^2-n+n\beta} (-zq; q^2)_n \alpha^n}{(\alpha q; q^2)_{n+1}}.
\end{aligned}$$

For  $t = 0$ ,  $\alpha = 1$ ,  $\beta = 1$  and  $z = 1$  these functions reduce to classical mock theta functions.

### 4. Relation between generalized eighth order mock theta functions

The differential operator  $D_q$  [8] is defined as

$$zD_{q,z}F(z, \alpha) = F(z, \alpha) - F(zq, \alpha).$$

By using the differential operator we shall connect the generalized eighth order mock theta functions.

**Proposition 1.** *The following is true:*

- (i)  $D_{q,t}^2 S_0(t, \alpha, \beta, z; q) = S_1(t, \alpha, \beta, z; q),$
- (ii)  $q^2 D_{q,t}^2 T_1(t, \alpha, \beta, z; q) = T_0(t, z, \alpha, \beta, z; q).$

*P r o o f.* Proof of (i):

$$\begin{aligned} tD_{q,t}S_0(t, \alpha, \beta, z; q) &= \frac{1}{(t)_\infty} \sum_{n=0}^{\infty} \frac{(t)_n q^{n^2-n+n\beta} (-zq; q^2)_n \alpha^n}{(-\alpha q^2; q^2)_n} - \frac{1}{(tq)_\infty} \sum_{n=0}^{\infty} \frac{(tq)_n q^{n^2-n+n\beta} (-zq; q^2)_n \alpha^n}{(-\alpha q^2; q^2)_n} \\ &= \frac{1}{(t)_\infty} \sum_{n=0}^{\infty} \frac{(t)_n q^{n^2-n+n\beta} (-zq; q^2)_n \alpha^n}{(-\alpha q^2; q^2)_n} - \frac{1}{(t)_\infty} \sum_{n=0}^{\infty} \frac{(t)_n q^{n^2-n+n\beta} (-zq; q^2)_n \alpha^n}{(-\alpha q^2; q^2)_n} (1 - tq^n) \\ &= \frac{t}{(t)_\infty} \sum_{n=0}^{\infty} \frac{(t)_n q^{n^2+n\beta} (-zq; q^2)_n \alpha^n}{(-\alpha q^2; q^2)_n}. \end{aligned}$$

Similarly

$$\begin{aligned} D_{q,t}^2 S_0(t, \alpha, \beta, z; q) &= \frac{1}{(t)_\infty} \sum_{n=0}^{\infty} \frac{(t)_n q^{n^2+n+n\beta} (-zq; q^2)_n \alpha^n}{(-\alpha q^2; q^2)_n} \\ &= \frac{1}{(t)_\infty} \sum_{n=0}^{\infty} \frac{(t)_n q^{n^2+2n-n+n\beta} (-zq; q^2)_n \alpha^n}{(-\alpha q^2; q^2)_n} = S_1(t, z, \alpha, \beta; q), \end{aligned}$$

which proves (i).

Proof of (ii):

$$D_{q,t}T_1(t, \alpha, \beta, z; q) = \frac{1}{(t)_\infty} \sum_{n=0}^{\infty} \frac{q^{n^2+2n-n+n\beta} (-q^2/\alpha; q^2)_n}{(-q/z; q^2)_{n+1} z^{n+1}},$$

and

$$\begin{aligned} D_{q,t}^2 T_1(t, \alpha, \beta, z; q) &= \frac{1}{(t)_\infty} \sum_{n=0}^{\infty} \frac{q^{n^2+3n-n+n\beta} (-q^2/\alpha; q^2)_n}{(-q/z; q^2)_{n+1} z^{n+1}}, \\ q^2 D_{q,t}^2 T_1(t, \alpha, \beta, z; q) &= \frac{1}{(t)_\infty} \sum_{n=0}^{\infty} \frac{q^{n^2+3n+2-n+n\beta} (-q^2/\alpha; q^2)_n}{(-q/z; q^2)_{n+1} z^{n+1}} = T_0(t, \alpha, \beta, z; q), \end{aligned}$$

which proves (ii). □

### 5. $q$ -Integral representation for the generalized eighth order mock theta functions

Thomae and Jackson [6, p. 19] defined  $q$ -integral

$$\int_0^1 f(t) d_q t = (1 - q) \sum_{n=0}^{\infty} f(q^n) q^n,$$

using limiting case of  $q$ -beta integral, we have

$$\frac{1}{(q^x; q)_\infty} = \frac{(1 - q)^{-1}}{(q; q)_\infty} \int_0^1 t^{x-1} (tq; q)_\infty d_q t.$$

We now represent these generalized functions as  $q$ -integral. By specializing the parameters we have the integral representation for classical mock theta functions.

**Theorem 1.**

- (i)  $S_0(q^t, \alpha, \beta, z; q) = \frac{(1-q)^{-1}}{(q; q)_\infty} \int_0^1 u^{t-1}(uq; q)_\infty S_0(0, \alpha, pu, z; q) d_q u,$
- (ii)  $T_0(q^t, \alpha, \beta, z; q) = \frac{(1-q)^{-1}}{(q; q)_\infty} \int_0^1 u^{t-1}(uq; q)_\infty T_0(0, \alpha, pu, z; q) d_q u,$
- (iii)  $U_0(q^t, \alpha, \beta, z; q) = \frac{(1-q)^{-1}}{(q; q)_\infty} \int_0^1 u^{t-1}(uq; q)_\infty U_0(0, \alpha, pu, z; q) d_q u,$
- (iv)  $V_0(q^t, \alpha, \beta, z; q) = \frac{(1-q)^{-1}}{(q; q)_\infty} \int_0^1 u^{t-1}(uq; q)_\infty V_0(0, \alpha, pu, z; q) d_q u,$
- (v)  $S_1(q^t, \alpha, \beta, z; q) = \frac{(1-q)^{-1}}{(q; q)_\infty} \int_0^1 u^{t-1}(uq; q)_\infty S_1(0, \alpha, pu, z; q) d_q u,$
- (vi)  $T_1(q^t, \alpha, \beta, z; q) = \frac{(1-q)^{-1}}{(q; q)_\infty} \int_0^1 u^{t-1}(uq; q)_\infty T_1(0, \alpha, pu, z; q) d_q u,$
- (vii)  $U_1(q^t, \alpha, \beta, z; q) = \frac{(1-q)^{-1}}{(q; q)_\infty} \int_0^1 u^{t-1}(uq; q)_\infty U_1(0, \alpha, pu, z; q) d_q u,$
- (viii)  $V_1(q^t, \alpha, \beta, z; q) = \frac{(1-q)^{-1}}{(q; q)_\infty} \int_0^1 u^{t-1}(uq; q)_\infty V_1(0, \alpha, pu, z; q) d_q u.$

*P r o o f.* A detailed proof for  $S_0(q^t, \alpha, \beta, z; q)$  is given. The proofs of the other functions are similar, so omitted.

Proof of (i): By definition

$$S_0(t, \alpha, \beta, z; q) = \frac{1}{(t)_\infty} \sum_{n=0}^{\infty} \frac{(t)_n q^{n^2-n+n\beta} (-zq; q^2)_n \alpha^n}{(-\alpha q^2; q^2)_n}.$$

Replacing  $t$  by  $q^t$ , we have

$$\begin{aligned} S_0(q^t, \alpha, \beta, z; q) &= \frac{1}{(q^t)_\infty} \sum_{n=0}^{\infty} \frac{(q^t)_n q^{n^2-n+n\beta} (-zq; q^2)_n \alpha^n}{(-\alpha q^2; q^2)_n} = \sum_{n=0}^{\infty} \frac{q^{n^2-n+n\beta} (-zq; q^2)_n \alpha^n}{(-\alpha q^2; q^2)_n (q^{n+t}; q)_\infty} \\ &= \sum_{n=0}^{\infty} \frac{q^{n^2-n+n\beta} (-zq; q^2)_n \alpha^n}{(-\alpha q^2; q^2)_n} \frac{(1-q)^{-1}}{(q; q)_\infty} \int_0^1 u^{t-1}(uq; q)_\infty d_q u, \end{aligned}$$

but

$$S_0(0, \alpha, \beta, z; q) = \sum_{n=0}^{\infty} \frac{q^{n^2-n+n\beta} (-zq; q^2)_n \alpha^n}{(-\alpha q^2; q^2)_n},$$

putting  $q^\beta = p$ , we have

$$S_0(0, \alpha, p, z; q) = \sum_{n=0}^{\infty} \frac{q^{n^2-n} (-zq; q^2)_n \alpha^n p^n}{(-\alpha q^2; q^2)_n},$$

$$S_0(q^t, \alpha, \beta, z; q) = \frac{(1-q)^{-1}}{(q; q)_\infty} \int_0^1 u^{t-1}(uq; q)_\infty S_0(0, \alpha, pu, z; q) d_q u,$$

which proves (i).

The proof of all the other functions is similar. Taking  $\alpha = 1$ ,  $\beta = 1$  and  $z = 1$  we have the integral representation of the classical eighth order mock theta functions.  $\square$

### 6. Multibasic expansion of generalized eighth order mock theta functions

The following bibasic expansion will be used to give multibasic expansion for the generalized functions.

**Theorem 2.** *The following is true:*

$$\sum_{k=0}^{\infty} \frac{(1 - ap^k q^k)(1 - bp^k q^{-k})(a, b; p)_k (c, a/bc; q)_k q^k}{(1 - a)(1 - b)(q, aq/b; q)_k (ap/c, bcp; p)_k} \sum_{m=0}^{\infty} \alpha_{m+k} = \sum_{m=0}^{\infty} \frac{(ap, bp; p)_m (cq, aq/bc; q)_m q^m}{(q, aq/b; q)_m (ap/c, bcp; p)_m} \alpha_m. \tag{6.1}$$

*P r o o f.* Using the summation formula [6, (3.6.7), p. 71] we have

$$\sum_{k=0}^n \frac{(1 - ap^k q^k)(1 - bp^k q^{-k})}{(1 - a)(1 - b)} \frac{(a, b; p)_k (c, a/bc; q)_k}{(q, aq/b; q)_k (ap/c, bcp; p)_k} q^k = \frac{(ap, bp; p)_n (cq, aq/bc; q)_n}{(q, aq/b; q)_n (ap/c, bcp; p)_n}$$

and [9, Lemma 10, p. 57],

$$\sum_{n=0}^{\infty} \sum_{k=0}^n B(k, n) = \sum_{n=0}^{\infty} \sum_{k=0}^{\infty} B(k, n + k),$$

therefore we get the statement of the theorem. □

We will consider the following case of Theorem 2.

**Case I.** Letting  $q \rightarrow q^3$  and  $c \rightarrow \infty$  in Theorem 1, we have

$$\sum_{k=0}^{\infty} \frac{(1 - ap^k q^{3k})(1 - bp^k q^{-3k})(a, b; p)_k q^{(3k^2+3k)/2}}{(1 - a)(1 - b)(q^3, aq^3/b; q^3)_k b^k p^{(k^2+k)/2}} \sum_{m=0}^{\infty} \alpha_{m+k} = \sum_{m=0}^{\infty} \frac{(ap, bp; p)_m q^{(3m^2+3m)/2}}{(q^3, aq^3/b; q^3)_m b^m p^{(m^2+m)/2}} \alpha_m. \tag{6.2}$$

**Theorem 3.** *The multibasic hypergeometric expansion of these generalized functions are:*

- (i)  $S_0(t, \alpha, 1, z; q) = \frac{1}{(t)_{\infty}} \sum_{k=0}^{\infty} \frac{(1 - tq^{4k-1})(1 - k^{-2k+2})(t; q)_{k-1} (-zq; q^2)_k q^{k^2} \alpha^k}{(1 - q^{k+2})(-\alpha q^2; q^2)_k} \times \phi \left[ \begin{matrix} q; -zq^{2k+1}; tq^{3k}, q^{3k+3} \\ q^{k+3}; -\alpha q^{2k+2}; 0 \end{matrix}; q, q^2, q^3; q\alpha \right],$
- (ii)  $T_0(t, \alpha, 1, z; q) = \frac{1}{(t)_{\infty}} \sum_{k=0}^{\infty} \frac{(1 - tq^{4k-1})(1 - k^{-2k+2})(t; q)_{k-1} (-q^2/\alpha; q^2)_k q^{k^2+3k+2} \alpha^k}{(1 - q^{k+2})(-q/z; q^2)_{k+1} z^{k+1}} \times \phi \left[ \begin{matrix} q; -q^{2k+2}/\alpha; tq^{3k}, q^{3k+3} \\ q^{k+3}; -q^{2k+2}/z; 0 \end{matrix}; q, q^2, q^3; q^4\alpha \right],$
- (iii)  $U_0(t, \alpha, 1, z; q) = \frac{1}{(t)_{\infty}} \sum_{k=0}^{\infty} \frac{(1 - tq^{4k-1})(1 - k^{-2k+2})(t; q)_{k-1} (-zq; q^2)_k q^{k^2} \alpha^k z^{2k}}{(1 - q^{k+2})(-\alpha q^4; q^4)_k} \times \phi \left[ \begin{matrix} q; -zq^{2k+1}; tq^{3k}, q^{3k+3}; 0 \\ q^{k+3}; 0; 0; -\alpha q^{4k+4} \end{matrix}; q, q^2, q^3, q^4; z^2 q\alpha \right],$

$$\begin{aligned}
\text{(iv)} \quad V_0(t, \alpha, 1, z; q) &= \frac{-1}{(t)_\infty} + \frac{1}{(t)_\infty} \sum_{k=0}^{\infty} \frac{(1-tq^{4k-1})(1-k^{-2k+2})(t; q)_{k-1}(-zq; q^2)_k q^{k^2} \alpha^k z^{2k}}{(1-q^{k+2})(\alpha q; q^2)_k} \\
&\quad \times \phi \left[ \begin{matrix} q; -zq^{2k+1}; tq^{3k}, q^{3k+3} \\ q^{k+3}; -\alpha q^{2k+1}; 0 \end{matrix}; q, q^2, q^3; q\alpha z^2 \right], \\
\text{(v)} \quad S_1(t, \alpha, 1, z; q) &= \frac{1}{(t)_\infty} \sum_{k=0}^{\infty} \frac{(1-tq^{4k-1})(1-k^{-2k+2})(t; q)_{k-1}(-zq; q^2)_k q^{k^2+2k} \alpha^k}{(1-q^{k+2})(-\alpha q^2; q^2)_k} \\
&\quad \times \phi \left[ \begin{matrix} q; -zq^{2k+1}; tq^{3k}, q^{3k+3} \\ q^{k+3}; -\alpha q^{2k+2}; 0 \end{matrix}; q, q^2, q^3; q^3 \alpha \right], \\
\text{(vi)} \quad T_1(t, \alpha, 1, z; q) &= \frac{1}{(t)_\infty} \sum_{k=0}^{\infty} \frac{(1-tq^{4k-1})(1-k^{-2k+2})(t; q)_{k-1}(-q^2/\alpha; q^2)_k q^{k^2+k} \alpha^k}{(1-q^{k+2})(-q/z; q^2)_{k+1} z^{k+1}} \\
&\quad \times \phi \left[ \begin{matrix} q; -q^{2k+2}/\alpha; tq^{3k}, q^{3k+3} \\ q^{k+3}; -q^{2k+3}/z; 0 \end{matrix}; q, q^2, q^3; q^2 z^{-1} \alpha \right], \\
\text{(vii)} \quad U_1(t, \alpha, 1, z; q) &= \frac{1}{(t)_\infty} \sum_{k=0}^{\infty} \frac{(1-tq^{4k-1})(1-k^{-2k+2})(t; q)_{k-1}(-zq; q^2)_k q^{(k+1)^2} \alpha^k z^{2k}}{(1-q^{k+2})(-\alpha q^2; q^4)_{k+1}} \\
&\quad \times \phi \left[ \begin{matrix} q; -zq^{2k+1}; tq^{3k}, q^{3k+3} \\ q^{k+3}; 0; 0; -\alpha q^{4k+6}; 0 \end{matrix}; q, q^2, q^3, q^4; q^3 z^2 \alpha \right], \\
\text{(viii)} \quad V_1(t, \alpha, 1, z; q) &= \frac{1}{(t)_\infty} \sum_{k=0}^{\infty} \frac{(1-tq^{4k-1})(1-k^{-2k+2})(t; q)_{k-1}(-zq; q^2)_k q^{(k+1)^2} \alpha^k z^{2k}}{(1-q^{k+2})(\alpha q; q^2)_{k+1}} \\
&\quad \times \phi \left[ \begin{matrix} q; -zq^{2k+1}; tq^{3k}, q^{3k+3} \\ q^{k+3}; \alpha q^{2k+3}; 0 \end{matrix}; q, q^2, q^3; q^3 z^2 \alpha \right].
\end{aligned}$$

P r o o f. We shall give the proof of (i) only, for others we will state the value of parameters.

Proof of (i): Taking  $a = t/q$ ,  $b = q^2$ ,  $p = q$  and

$$\alpha_m = \frac{(q^3; q^3)_m (t; q^3)_m (-zq; q^2)_m \alpha^m q^m}{(q^3; q)_m (-\alpha q^2; q^2)_m} \quad \text{in (6.2),}$$

we have

$$\begin{aligned}
&\sum_{k=0}^{\infty} \frac{(1-tq^{4k-1})(1-q^{-2k+2})(t/q, q^2; q)_k q^{k^2+k}}{(1-t/q)(1-q^2)(q^3, t; q^3)_k q^{2k}} \\
&\quad \times \sum_{m=0}^{\infty} \frac{(t, q^3)_{m+k} (q^3; q^3)_{m+k} (-zq; q^2)_{m+k} \alpha^{m+k} q^{m+k}}{(q^3; q)_{m+k} (-\alpha q^2; q^2)_{m+k}} \\
&= \sum_{m=0}^{\infty} \frac{(t, q^3; q)_m q^{m^2+m}}{(q^3, t; q^3)_m q^{2m}} \frac{(q^3; q^3)_m (t; q^3)_m (-zq; q^2)_m \alpha^m q^m}{(q^3; q)_m (-\alpha q^2; q^2)_m}.
\end{aligned} \tag{6.3}$$

The right hand side is equal to

$$\begin{aligned}
&\sum_{m=0}^{\infty} \frac{(t, q^3; q)_m q^{m^2+m}}{(q^3, t; q^3)_m q^{2m}} \frac{(q^3; q^3)_m (t; q^3)_m (-zq; q^2)_m \alpha^m q^m}{(q^3; q)_m (-\alpha q^2; q^2)_m} \\
&= \sum_{m=0}^{\infty} \frac{(t; q)_m (-zq; q^2)_m q^{m^2} \alpha^m}{(-\alpha q^2; q^2)_m} = (t)_\infty S_0(t, \alpha, \beta, z; q).
\end{aligned}$$

The left hand side of (6.3) is equal to

$$\begin{aligned} & \sum_{k=0}^{\infty} \frac{(1-tq^{4k-1})(1-q^{-2k+2})(t/q, q^2; q)_k q^{k^2+k}}{(1-t/q)(1-q^2)(q^3, t; q^3)_k q^{2k}} \\ & \times \sum_{m=0}^{\infty} \frac{(t; q^3)_k (tq^3; q^3)_m (q^3; q^3)_k (q^{3k+3}; q^3)_m (-zq; q^2)_k (-zq^{2k+1}; q^2)_m \alpha^{m+k} q^{m+k}}{(q^3; q)_k (q^{k+3}; q)_m (-\alpha q^2; q^2)_k (-\alpha q^{2k+2}; q^2)_m} \\ & = \sum_{k=0}^{\infty} \frac{(1-tq^{4k-1})(1-q^{-2k+2})(t; q)_{k-1} (-zq; q^2)_k q^{k^2} \alpha^k}{(1-q^{k+2})(-\alpha q^2; q^2)_k} \\ & \quad \times \sum_{m=0}^{\infty} \frac{(tq^3; q^3)_m (q^{3k+3}; q^3)_m (-zq^{2k+1}; q^2)_m \alpha^m q^m}{(q^{k+3}; q)_m (-\alpha q^{2k+2}; q^2)_m} \\ & = \frac{1}{(t)_{\infty}} \sum_{k=0}^{\infty} \frac{(1-tq^{4k-1})(1-q^{-2k+2})(t; q)_{k-1} (-zq; q^2)_k q^{k^2} \alpha^k}{(1-q^{k+2})(-\alpha q^2; q^2)_k} \\ & \quad \times \phi \left[ \begin{matrix} q; -zq^{2k+1}, tq^{3k}, q^{3k+3} \\ q^{k+3}, -\alpha q^{2k+2}; 0 \end{matrix}; q, q^2, q^3; q\alpha \right] \end{aligned}$$

which proves (i).

Proof of (ii): Take  $a = t/q, b = q^2, p = q$  and

$$\alpha_m = \frac{(q^3; q^3)_m (t; q^3)_m (-q^2/\alpha; q^2)_m q^{4m+2} \alpha^m}{(q^3; q)_m (-q/z; q^2)_{m+1} z^{m+1}} \quad \text{in (6.2).}$$

Proof of (iii): Take  $a = t/q, b = q^2, p = q$  and

$$\alpha_m = \frac{(q^3; q^3)_m (t; q^3)_m (-zq; q^2)_m q^m z^{2m} \alpha^m}{(q^3; q)_m (-\alpha q^4; q^4)_m} \quad \text{in (6.2).}$$

Proof of (iv): Take  $a = t/q, b = q^2, p = q$  and

$$\alpha_m = \frac{(q^3; q^3)_m (t; q^3)_m (-zq; q^2)_m q^m z^{2m} \alpha^m}{(q^3; q)_m (\alpha q; q^2)_m} \quad \text{in (6.2).}$$

Proof of (v): Take  $a = t/q, b = q^2, p = q$  and

$$\alpha_m = \frac{(q^3; q^3)_m (t; q^3)_m (-zq; q^2)_m q^{3m} \alpha^m}{(q^3; q)_m (-\alpha q^2; q^2)_m} \quad \text{in (6.2).}$$

Proof of (vi): Take  $a = t/q, b = q^2, p = q$  and

$$\alpha_m = \frac{(q^3; q^3)_m (t; q^3)_m (-q^2/\alpha; q^2)_m q^{2m} \alpha^m}{(q^3; q)_m (-q/z; q^2)_{m+1} z^{m+1}} \quad \text{in (6.2).}$$

Proof of (vii): Take  $a = t/q, b = q^2, p = q$  and

$$\alpha_m = \frac{(q^3; q^3)_m (t; q^3)_m (-zq; q^2)_m q^{3m+1} z^{2m} \alpha^m}{(q^3; q)_m (-\alpha q^2; q^4)_{m+1}} \quad \text{in (6.2).}$$

Proof of (viii): Take  $a = t/q, b = q^2, p = q$  and

$$\alpha_m = \frac{(q^3; q^3)_m (t; q^3)_m (-zq; q^2)_m q^{3m+1} z^{2m} \alpha^m}{(q^3; q)_m (\alpha q; q^2)_{m+1}} \quad \text{in (6.2).}$$

By taking  $\alpha = 1, \beta = 1$  and  $z = 1$  we have multibasic expansion of classical eighth order mock theta functions.



## 7. Special cases and Ramanujan's cubic continued fraction

**Proposition 2.** *We have the following special cases*

$$\begin{aligned} \text{(i)} \quad U_0(0, -1, 1, 1; q) &= \frac{f(-q, -q)}{\psi(-q)}, \\ \text{(ii)} \quad U_0(0, -1, 1, 1; -q) &= \frac{f(-q^2, -q^2)}{\psi(-q)}, \\ \text{(iii)} \quad U_0(0, -1, 3, -1; -q) &= \frac{f(-q, -q^5)}{\psi(-q)}, \\ \text{(iv)} \quad U_0(0, -1, 1, -1; -q) &= \frac{f(-q^3, -q^3)}{\psi(-q)}. \end{aligned}$$

**P r o o f.** Proof of (i): By definition we have

$$U_0(t, \alpha, \beta, z; q) = \frac{1}{(t)_\infty} \sum_{n=0}^{\infty} \frac{(t)_n q^{n^2 - n + n\beta} (-zq; q^2)_n \alpha^n}{(-\alpha q^4; q^4)_n}, \quad (7.1)$$

put  $t = 0$ ,  $\alpha = -1$ ,  $\beta = 1$  and  $z = 1$ , therefore we have

$$U_0(0, -1, 1, 1; q) = \sum_{n=0}^{\infty} \frac{(-1)^n q^{n^2} (-q; q^2)_n}{(q^4; q^4)_n}, \quad (7.2)$$

from [10, eq. (A.13), p. 171], we have

$$\frac{f(-q, -q)}{\psi(-q)} = \sum_{n=0}^{\infty} \frac{(-1)^n q^{n^2} (-q; q^2)_n}{(q^4; q^4)_n}, \quad (7.3)$$

by (7.2) and (7.3), we get

$$U_0(0, -1, 1, 1; q) = \frac{f(-q, -q)}{\psi(-q)},$$

which proves (i).

Proof of (ii): Put  $t = 0$ ,  $\alpha = -1$ ,  $\beta = 1$ ,  $z = 1$  and replace  $q = -q$  in (7.1), we have

$$U_0(0, -1, 1, 1; -q) = \sum_{n=0}^{\infty} \frac{q^{n^2} (q; q^2)_n}{(q^4; q^4)_n}, \quad (7.4)$$

from [10, eq. (A. 23), p. 172], we have

$$\frac{f(-q^2, -q^2)}{\psi(-q)} = \sum_{n=0}^{\infty} \frac{q^{n^2} (q; q^2)_n}{(q^4; q^4)_n}, \quad (7.5)$$

by (7.4) and (7.5), we get

$$U_0(0, -1, 1, 1; -q) = \frac{f(-q^2, -q^2)}{\psi(-q)},$$

which proves (ii).

Proof of (iii): Put  $t = 0$ ,  $\alpha = -1$ ,  $\beta = 3$ ,  $z = -1$  and replace  $q = -q$  in (7.1), we have

$$U_0(0, -1, 3, -1; -q) = \sum_{n=0}^{\infty} \frac{q^{n^2+2n}(-q; q^2)_n}{(q^4; q^4)_n}, \tag{7.6}$$

from [10, eq. (A. 52), p. 175], we have

$$\frac{f(-q, -q^5)}{\psi(-q)} = \sum_{n=0}^{\infty} \frac{q^{n^2+2n}(-q; q^2)_n}{(q^4; q^4)_n}, \tag{7.7}$$

by (7.6) and (7.7), we get

$$U_0(0, -1, 3, -1; -q) = \frac{f(-q, -q^5)}{\psi(-q)}, \tag{7.8}$$

which proves (iii).

Proof of (iv): Put  $t = 0$ ,  $\alpha = -1$ ,  $\beta = 1$ ,  $z = -1$  and replace  $q = -q$  in (7.1), we have

$$U_0(0, -1, 1, -1; -q) = \sum_{n=0}^{\infty} \frac{q^{n^2}(-q; q^2)_n}{(q^4; q^4)_n}, \tag{7.9}$$

from [10, eq. (A. 53), p. 175], we have

$$\frac{f(-q^3, -q^3)}{\psi(-q)} = \sum_{n=0}^{\infty} \frac{q^{n^2}(-q; q^2)_n}{(q^4; q^4)_n}, \tag{7.10}$$

by (7.9) and (7.10), we get

$$U_0(0, -1, 1, -1; -q) = \frac{f(-q^3, -q^3)}{\psi(-q)}, \tag{7.11}$$

which proves (iv). □

*Remark 1.* Dividing (7.8) by (7.11), we have

$$\frac{U_0(0, -1, 3, -1; -q)}{U_0(0, -1, 1, -1; -q)} = \frac{f(-q, -q^5)}{f(-q^3, -q^3)} = 1 + \frac{q + q^2}{1} + \frac{q^2 + q^4}{1} + \frac{q^3 + q^6}{1} + \dots$$

which is Ramanujan’s cubic continued fraction [2, (3.1.6), p. 86].

### 8. Conclusion

The advantage of the generalization presented in the paper is that by specializing the parameters we can obtain known functions which connects mock theta functions with continued fractions. So the results obtained for mock theta functions are reduced to continued fractions.

### Acknowledgement

The author thanks the reviewers for their useful comments and Prof. Bhaskar Srivastava for his guidance.

## REFERENCES

1. Andrews G.E. On basic hypergeometric series, mock theta functions and partitions (I). *Q. J. Math.*, 1966. Vol. 17, No. 2. P. 64–80. DOI: [10.1093/qmath/17.1.64](https://doi.org/10.1093/qmath/17.1.64)
2. Andrews G.E., Berndt B.C. *Ramanujan's Lost Notebook. Part I*. New York: Springer-Verlag, 2005. 437 p. DOI: [10.1007/0-387-28124-X](https://doi.org/10.1007/0-387-28124-X)
3. Andrews G.E., and Hickerson D. Ramanujan's "lost" notebook VII: The sixth order mock theta functions. *Adv. Math.*, 1991. Vol. 89, No. 1. P. 60–105. DOI: [10.1016/0001-8708\(91\)90083-J](https://doi.org/10.1016/0001-8708(91)90083-J)
4. Choi Y.-S. The basic bilateral hypergeometric series and the mock theta functions. *Ramanujan J.*, 2011. Vol. 24. P. 345–386. DOI: [10.1007/s11139-010-9269-7](https://doi.org/10.1007/s11139-010-9269-7)
5. *Collected Papers of Srinivasa Ramanujan*. Hardy G.H., Seshu Aiyar P.V., Wilson B.M. (eds.) New York: Chelsea Pub. Co., 1962 (©1927). 355 p.
6. Gasper G., Rahman M. *Basic Hypergeometric Series*. Cambridge: Cambridge University Press, 1990. 276 p.
7. Gordon B., MacIntosh R.J. Some eighth order mock theta functions. *J. London Math. Soc.*, 2000. Vol. 62, No. 2. P. 321–335. DOI: [10.1112/S0024610700008735](https://doi.org/10.1112/S0024610700008735)
8. Jackson F.H. Basic Integration. *Q. J. Math.*, 1951. Vol. 2, No. 1. P. 1–16. DOI: [10.1093/qmath/2.1.1](https://doi.org/10.1093/qmath/2.1.1)
9. Rainville E.D. *Special Function*. New York: Chelsea Pub. Co., 1960. 365 p.
10. Sills A. V. *An Invitation to the Rogers-Ramanujan Identities*. New York: Chapman and Hall/CRC, 2017. 256 p. DOI: [10.1201/9781315151922](https://doi.org/10.1201/9781315151922)
11. Srivastava B. A generalization of the eighth order mock theta functions and their multibasic expansion. *Saitama Math. J.*, 2006/2007. Vol. 24. P. 1–13.
12. Watson G.N. The final problem: An account of the mock theta functions. *J. London Math. Soc.*, 1936. Vol. 11. P. 55–80. DOI: [10.1112/jlms/s1-11.1.55](https://doi.org/10.1112/jlms/s1-11.1.55)

# DOMINATION AND EDGE DOMINATION IN TREES<sup>1</sup>

B. Senthilkumar<sup>†</sup>, Y. B. Venkatakrishnan<sup>††</sup>, H. Naresh Kumar<sup>†††</sup>

SASTRA Deemed University, Tanjore, Tamilnadu, India

<sup>†</sup>senthilsubramanian@gmail.com   <sup>††</sup>venkatakrish2@maths.sastra.edu

<sup>†††</sup>nareshhari1403@gmail.com

**Abstract:** Let  $G = (V, E)$  be a simple graph. A set  $S \subseteq V$  is a dominating set if every vertex in  $V \setminus S$  is adjacent to a vertex in  $S$ . The domination number of a graph  $G$ , denoted by  $\gamma(G)$  is the minimum cardinality of a dominating set of  $G$ . A set  $D \subseteq E$  is an edge dominating set if every edge in  $E \setminus D$  is adjacent to an edge in  $D$ . The edge domination number of a graph  $G$ , denoted by  $\gamma'(G)$  is the minimum cardinality of an edge dominating set of  $G$ . We characterize trees with domination number equal to twice edge domination number.

**Keywords:** Edge dominating set, Dominating set, Trees.

## 1. Introduction

Domination theory is a well studied topic in graph theory. Depending on the utility in real life application, domination on vertex set and on edge set has been defined. Edge dominating set is used to study the behaviour of telephone switching network [5] built to phone calls from one telephone to another telephone at a time. Edge dominating set is also used in deterministic distributed algorithms in networks with unique node identifier in port numbered network. Dominating set is used to identify the minimum number of servers in an adhoc network. For different dominating parameters, the reader is referred to two excellent books [2, 3].

In domination theory, comparison is made between domination parameters defined on vertex set or domination parameters defined on edge set. There are only a few studies on comparison between domination parameter defined on vertex set with a domination parameter defined on edge set, see [4, 8]. Here, a domination parameter defined on edge set, edge domination, is compared with a domination parameter defined on vertex set, vertex domination and we characterize trees with domination number equal to twice edge domination number.

Let  $G = (V, E)$  be a simple connected graph. Two edges are adjacent if they are incident with a common vertex. Two vertices  $u$  and  $v$  are adjacent if there is an edge  $e$  incident with both  $u$  and  $v$ . For every vertex  $v \in V$ , the set of all vertices adjacent to  $v$  is an *open neighborhood* of the vertex  $v$  denoted by  $N(v)$  and the set  $N[v] = N(v) \cup \{v\}$  is called the *closed neighborhood* of vertex  $v$ . The *degree* of a vertex  $v$  is the cardinality of its open neighborhood, denoted  $d_G(v) = |N(v)|$ . A vertex of degree one is called a *leaf* and its neighbor is called a *support vertex*. A support vertex with more than one leaf is called a *strong support vertex* and a support vertex with exactly one leaf is called a *weak support vertex*. The number of edges between  $u$  and  $v$  in a shortest path is the *distance* between vertices  $u$  and  $v$ . The longest distance between any pair of vertices is defined as the *diameter* of the graph  $G$ , and is denoted by  $\text{diam}(G)$ . A path on  $n$  vertices is denoted by  $P_n$ . A vertex  $v$  in a tree  $T$  is adjacent to a path  $P_n$  through its vertex  $x$ , if a path containing  $x$  is one of the components of  $(T - vx)$ . A *star* of order  $n \geq 2$ , denoted by  $K_{1,n-1}$ , is a tree with at least  $(n - 1)$  leaves. A *double star* is a tree with exactly two support vertices and is denoted by  $D_{r,s}$ , where  $r$  and  $s$  are the number of leaves attached to each support vertices.

<sup>1</sup>This work is supported by TATA-Realty and Infrastructure Limited.

A subset  $S$  of  $V$  is a *dominating set* abbreviated DS, if every vertex in  $V \setminus S$  is adjacent to some vertex in  $S$ . The *domination number*,  $\gamma(G)$  of a graph  $G$ , is the minimum cardinality of a DS of  $G$ . By  $\gamma(G)$ -set, we mean a DS with minimum cardinality of a graph  $G$ .

A subset  $D$  of  $E$  is a *edge dominating set* abbreviated EDS, if every edge in  $E \setminus D$  is adjacent to some edge in  $D$ . The *edge domination number*,  $\gamma'(G)$  of a graph  $G$ , is the minimum cardinality of a EDS of  $G$ . By  $\gamma'(G)$ -set, we mean an EDS with minimum cardinality of graph  $G$ . For more properties on edge dominating set, refer the reader to [1, 7].

Characterizing trees with equal dominating parameters is available in the literature, see [6]. We characterize trees with domination number equal to twice edge domination number.

## 2. Main results

We begin this section with a theorem.

**Theorem 1.** *For any tree  $T$ ,  $\gamma'(T) \leq \gamma(T) \leq 2\gamma'(T)$ .*

*P r o o f.* Let  $D$  be a  $\gamma'(T)$ -set. Let  $S$  be the set of vertices incident with the edges of  $D$ . The set  $S$  is a DS of tree  $T$ . Thus  $\gamma(T) \leq |S| \leq 2|D| = 2\gamma'(T)$ .

Let  $S$  be a  $\gamma(T)$ -set. For each vertex of  $S$ , select exactly one edge incident with it, and call such a set of edges as  $D$ . Then  $D$  is an EDS of tree  $T$ . We have  $\gamma'(T) \leq |D| = |S| = \gamma(T)$ .  $\square$

For the purpose of characterizing trees with equal domination number and twice edge domination number, we introduce the family  $\mathcal{A}$  of trees  $T = T_k$  that can be obtained as follows.

Let  $T_1 = P_4$ . If  $k \geq 2$ , then  $T_{k+1}$  can be obtained recursively from  $T_k$  by one of the following operations:

- Operation  $\mathcal{O}_1$ : Attach a vertex to a support vertex of  $T_k$ .
- Operation  $\mathcal{O}_2$ : Attach a 4-path by joining its support vertex to a vertex of  $T_k$  adjacent to a 4-path through its support vertex.
- Operation  $\mathcal{O}_3$ : Attach a 4-path by joining its support vertex to a support vertex of  $T_k$ .
- Operation  $\mathcal{O}_4$ : Attach a double star  $D_{r,s}$  with  $r \cdot s \geq 2$  by joining a leaf adjacent to a strong support vertex to a vertex of  $T_k$  adjacent to a 2-path.
- Operation  $\mathcal{O}_5$ : Attach a double star  $D_{r,s}$  with  $r \cdot s \geq 2$  by joining a leaf adjacent to a strong support vertex to a support vertex of  $T_k$ .

The operations given above are illustrated in Figure 1. It is proved that  $\gamma(T) = 2\gamma'(T)$  for every tree  $T$  of the family  $\mathcal{A}$ .

**Lemma 1.** *If  $T \in \mathcal{A}$ , then  $\gamma(T) = 2\gamma'(T)$ .*

*P r o o f.* To construct the tree  $T$ , we use the method of induction on the number  $k$  of operations. If  $T = P_4$ , then obviously  $\gamma(T) = 2 = 2\gamma'(T)$ . Let  $k$  be a positive integer. Assume that the result is true for every  $T' = T_k$  of the family  $\mathcal{A}$  constructed by  $k - 1$  operations. Let  $T = T_{k+1}$  be a tree of the family  $\mathcal{A}$  constructed by  $k$  operations.

First assume that  $T$  is obtained from  $T'$  by operation  $\mathcal{O}_1$ . Let  $D'$  be a  $\gamma'(T')$ -set. It is easy to see that  $D'$  is an EDS of tree  $T$ . Thus  $\gamma'(T) \leq \gamma'(T')$ . Obviously,  $\gamma(T') \leq \gamma(T)$ . We now get

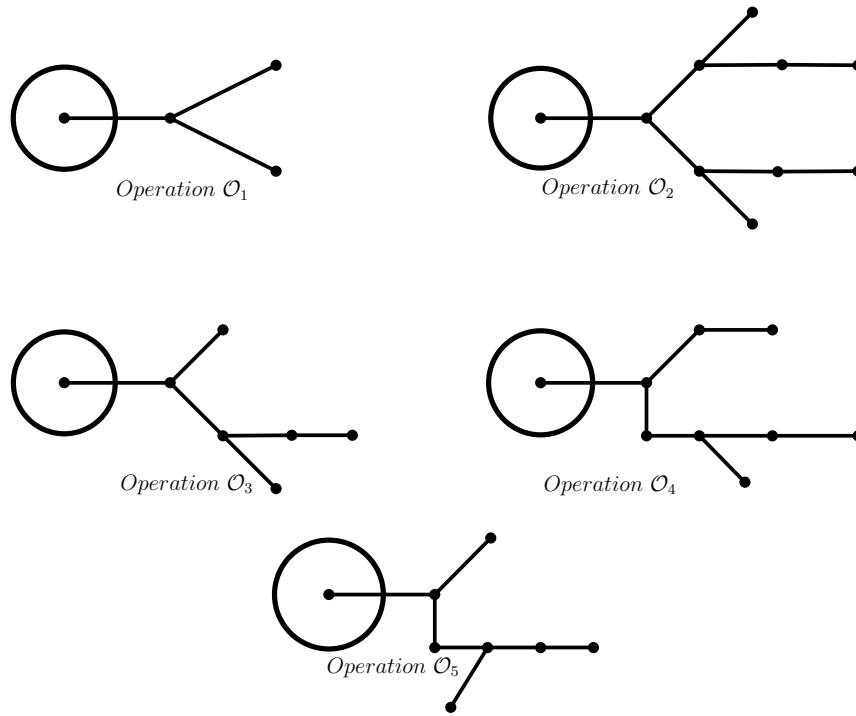

Figure 1. Operations  $\mathcal{O}_1$  to  $\mathcal{O}_5$

$2\gamma'(T) \leq 2\gamma'(T') = \gamma(T') \leq \gamma(T)$ . On the other hand by Theorem 1, we have  $\gamma(T) \leq 2\gamma'(T)$ . This implies that  $\gamma(T) = 2\gamma'(T)$ .

Now assume that the tree  $T$  is obtained from the tree  $T'$  by the operation  $\mathcal{O}_2$ . Let  $x$  be the vertex to which a 4-path  $pqrs$  is joined through  $q$ . Let  $q$  be adjacent to  $x$ . Let  $abcd$  be a path different from path  $pqrs$  with the vertex  $b$  adjacent to  $x$ . Let  $D'$  be a  $\gamma'(T)$ -set. To dominate the edges  $cd, bc, ab$  and  $bx$ , the edge  $bc \in D'$ . It is clear that  $D' \cup \{qr\}$  is an EDS of  $T$ . Thus  $\gamma'(T) \leq \gamma'(T') + 1$ . Let  $S$  be a  $\gamma(T)$ -set. To dominate the vertices  $d, a, s$  and  $p$ , the vertices  $c, b, r, q \in S$ . It is obvious that  $S \setminus \{q, r\}$  is a DS of tree  $T'$ . Thus  $\gamma(T') \leq \gamma(T) - 2$ . We obtain  $2\gamma'(T) \leq 2\gamma'(T') + 2 = \gamma(T') + 2 \leq \gamma(T)$ . We conclude that  $2\gamma'(T) = \gamma(T)$ .

Now assume that  $T$  is obtained from  $T'$  by the operation  $\mathcal{O}_3$ . Let  $x$  be the vertex to which the 4-path  $pqrs$  is attached by joining  $q$  and  $x$ . Let  $y$  be a leaf adjacent to  $x$ . Let  $D'$  denote a  $\gamma'(T')$ -set. It is clear that  $D' \cup \{q, r\}$  is an EDS of tree  $T$ . Thus  $\gamma'(T) \leq \gamma'(T') + 1$ . Let  $S$  be a  $\gamma(T)$ -set. To dominate the vertices  $s, p$  and  $y$ , the vertices  $r, q, x \in S$ . It is obvious that  $S \setminus \{q, r\}$  is a dominating set of the tree  $T'$ . Thus  $\gamma(T') \leq \gamma(T) - 2$ . We now get  $2\gamma'(T) \leq 2\gamma'(T') + 2 = \gamma(T') + 2 \leq \gamma(T)$ . We conclude that  $2\gamma'(T) = \gamma(T)$ .

Now assume that  $T$  is obtained from  $T'$  by the operation  $\mathcal{O}_4$ . Let  $p$  and  $q$  be support vertices of a double star. Let  $r$  and  $s$  be two leaves adjacent to  $p$ , and  $t$  be the leaf adjacent to  $q$ . Denote by  $x$  the vertex to which the double star is attached. Let  $r$  be adjacent to  $x$ . Let  $x$  be adjacent to 2-path  $ab$  with  $a$  adjacent to  $x$ . Let  $D'$  be a  $\gamma(T')$ -set. To dominate the edge  $ab$ , the edge  $xa \in D'$ . The set  $D' \cup \{pq\}$  is an EDS of tree  $T$ . Thus  $\gamma'(T) \leq \gamma'(T') + 1$ . Let  $S$  be a  $\gamma(T)$ -set. To dominate the vertices  $t, s$  and  $b$ , the vertices  $q, p, a \in S$ . It is easy to observe  $S \setminus \{p, q\}$  is a dominating set of the tree  $T'$ . Thus  $\gamma(T') \leq \gamma(T) - 2$ . We now get  $2\gamma'(T) \leq 2\gamma'(T') + 2 = \gamma(T') + 2 \leq \gamma(T)$ . We conclude that  $\gamma(T) = 2\gamma'(T)$ .

Assume that  $T$  is obtained from  $T'$  by the operation  $\mathcal{O}_5$ . Let  $p$  and  $q$  be support vertices of

the attached double star. Let  $r$  and  $s$  be two leaves adjacent to  $p$ , and  $t$  be a leaf adjacent to  $q$ . Denote by  $x$  the support vertex to which the double star is attached. Let  $r$  be adjacent to  $x$ . The leaf adjacent to  $x$  is denoted by  $y$ . Let  $D'$  represent a  $\gamma'(T')$ -set. The set  $D' \cup \{pq\}$  is an EDS of the tree  $T$ . Thus  $\gamma'(T) \leq \gamma'(T') + 1$ . Let  $S$  be a  $\gamma(T)$ -set. The vertices  $t, s$  and  $y$ , are dominated by the vertices  $p, q, x \in S$ . The set  $S \setminus \{p, q\}$  is a DS of the tree  $T'$ . Thus  $\gamma(T') \leq \gamma(T) - 2$ . We now get  $2\gamma'(T) \leq 2\gamma'(T') + 2 = \gamma(T') + 2 \leq \gamma(T)$ . We conclude that  $\gamma(T) = 2\gamma'(T)$ .  $\square$

We now prove that if  $2\gamma'(T) = \gamma(T)$ , then the tree belongs to the family  $\mathcal{A}$ .

**Lemma 2.** *Let  $T$  be a tree. If  $2\gamma'(T) = \gamma(T)$ , then  $T \in \mathcal{A}$ .*

*P r o o f.* If  $\text{diam}(T) = 1$ , then  $T = P_2$ . We have  $\gamma(P_2) = 1 < 2 = 2\gamma'(P_2)$ . If  $\text{diam}(T) = 2$ , then  $T$  is a star. We have  $\gamma(P_3) = 1 < 2 = 2\gamma'(P_3)$ . If  $\text{diam}(T) = 3$ , the tree  $T$  is a double star. If  $T = P_4$ , then  $T \in \mathcal{A}$ . If  $T$  is a double star other than  $P_4$ , then  $T$  is obtained from  $P_4$  by required number of operations  $\mathcal{O}_1$ . Thus  $T \in \mathcal{A}$ . Let  $\text{diam}(T) \geq 4$ . Thus the order  $n$  of the tree  $T$  is at least five. The method of induction on the order  $n$  is used to prove the result. Assume that the lemma is valid for every tree  $T'$  of order  $n' < n$ .

Assume that the support vertex of  $T$ , say  $x$ , is strong. Let  $p$  and  $q$  be leaves adjacent to  $x$ . Let  $T' = T - p$ . Let  $D$  be a  $\gamma'(T)$ -set. If  $xp \in D$  then  $(D \setminus \{xp\}) \cup \{xq\}$  is an EDS of  $T'$ . If  $xp \notin D$  then obviously  $D$  is an EDS of  $T'$ . Thus  $\gamma'(T') \leq \gamma'(T)$ . Let  $S'$  be a  $\gamma(T')$ -set. Obviously  $S'$  is a DS of the tree  $T$ . Thus  $\gamma(T) \leq \gamma(T')$ . We now get  $2\gamma'(T') \leq 2\gamma'(T) = \gamma(T) \leq \gamma(T')$ . This implies that  $\gamma(T') = 2\gamma'(T')$ . We have  $T' \in \mathcal{A}$  from the inductive hypothesis. The tree  $T$  is obtained from  $T'$  by operation  $\mathcal{O}_1$ . Thus  $T \in \mathcal{A}$ . Hereafter, it is assumed that every support vertex of  $T$  is weak.

Let  $r$  be a vertex of maximum eccentricity  $\text{diam}(T)$ . We assume that  $r$  is the root of the tree  $T$ . The leaf at a maximum distance from  $r$  is denoted by  $t$ ,  $t$  be the child of  $v$ , let  $v$  be the child of  $u$  in the rooted tree. If  $\text{diam}(T) \geq 4$ , then let  $u$  be the child of  $w$ . If  $\text{diam}(T) \geq 5$ , then let  $w$  be the child of  $d$ . If  $\text{diam}(T) \geq 6$ , then let  $d$  be the child of  $e$ . The subtree induced by descendants of  $x$  and a vertex  $x$  in the rooted tree  $T$  is denoted by  $T_x$ .

Among the children of  $u$  assume that there is a support vertex, say  $x$ , other than  $v$ . Let  $y$  be the leaf adjacent to  $x$ . Let  $T' = T - T_v$ . Let  $D'$  be a  $\gamma(T')$ -set. The set  $D' \cup \{v\}$  is a DS of  $T$ . Thus  $\gamma(T) \leq \gamma(T') + 1$ . Let  $S$  be a  $\gamma'(T)$ -set. To dominate the edges  $vt$  and  $xy$ , the edges  $uv, ux \in S$ . It is obvious that  $S \setminus \{uv\}$  is EDS of the tree  $T'$ . Thus  $\gamma'(T') \leq \gamma'(T) - 1$ . We obtain

$$2\gamma'(T') \leq 2\gamma'(T) - 2 = \gamma(T) - 2 \leq \gamma(T') + 1 - 2 < \gamma(T').$$

By Theorem 1 this case is impossible.

Assume that some child of  $u$ , say  $x$ , is a leaf. By the choice of diametrical path, the vertex  $w$  is adjacent to isomorphic copy of  $T_u$  or adjacent to path  $P_3$  or adjacent to path  $P_2$  or a support vertex of  $T$ .

**Case (i):** Let  $w$  be adjacent to isomorphic copy of  $T_u$ , say  $T_{u'}$ . Let  $T_{u'} = t'v'u'x'$ . Let  $u'$  be adjacent to  $w$ . Let  $T' = T - T_u$ . Let  $D$  be a  $\gamma'(T)$ -set. To dominate the edges  $vt, uv, ux, v't', u'v'$  and  $u'x'$ , the edges  $uv, u'v' \in D$ . It is obvious that  $D \setminus \{uv\}$  is an EDS of  $T'$ . Thus  $\gamma'(T') \leq \gamma'(T) - 1$ . Let  $S'$  be a  $\gamma(T')$ -set. The set  $S' \cup \{u, v\}$  is a DS of the tree  $T$ . Thus  $\gamma(T) \leq \gamma(T') + 2$ . We now obtain  $2\gamma'(T') \leq 2\gamma'(T) - 2 = \gamma(T) - 2 \leq \gamma(T')$ . This gives that  $\gamma(T') = 2\gamma'(T')$ . The tree  $T' \in \mathcal{A}$  by the inductive hypothesis. The tree  $T$  can be constructed from  $T'$  by operation  $\mathcal{O}_2$ . Thus  $T \in \mathcal{A}$ .

**Case (ii):** Let  $w$  be adjacent to a 3-path  $abc$ . Let  $a$  be adjacent to  $w$ . Let  $T' = T - T_a$ . Let  $D$  be a  $\gamma'(T)$ -set. To dominate the edges  $vt, uv, ux, uw, wa, ab$  and  $bc$ , the edges  $uv, ab \in D$ . It is clear that  $D \setminus \{ab\}$  is an EDS of the tree  $T'$ . Thus  $\gamma'(T') \leq \gamma'(T) - 1$ . Let  $S'$  be a  $\gamma(T')$ -set. The set  $S' \cup \{b\}$  is obviously a DS of tree  $T$ . Thus  $\gamma(T) \leq \gamma(T') + 1$ . We now obtain

$$2\gamma'(T') \leq 2\gamma'(T) - 2 = \gamma(T) - 2 \leq \gamma(T') + 1 - 2 < \gamma(T').$$

By Theorem 1 this case is impossible.

**Case (iii):** Suppose  $w$  is adjacent to 2-path  $xy$ . Let  $w$  be adjacent to 2-path  $x'y'$  different from 2-path  $xy$ . Let  $T' = T - T_x$ . Let  $D$  be a  $\gamma'(T)$ -set. To dominate the edges  $wx, xy, wx'$  and  $x'y'$ , the edges  $wx, wx' \in D$ . The set  $D \setminus \{wx\}$  is an EDS of  $T'$ . Thus  $\gamma'(T') \leq \gamma'(T) - 1$ . Let  $S'$  be a  $\gamma(T')$ -set. The set  $S' \cup \{x\}$  is clearly a DS of tree  $T$ . Thus  $\gamma(T) \leq \gamma(T') + 1$ . We now obtain  $2\gamma'(T') \leq 2\gamma'(T) - 2 = \gamma(T) - 2 \leq \gamma(T') + 1 - 2 < \gamma(T')$ . Suppose the vertex  $w$  is adjacent to exactly one 2-path  $xy$ . Let  $T' = T - T_w$ . Let  $D$  be a  $\gamma'(T)$ -set. The edges  $uw$  and  $wx$  are in  $D$ . The set  $D \setminus \{uw, wx\}$  is an EDS of tree  $T'$ . Thus  $\gamma'(T') \leq \gamma'(T) - 2$ . Let  $S'$  be a  $\gamma(T')$ -set. It is obvious that  $S' \cup \{u, v, x\}$  is a DS of tree  $T$ . Thus  $\gamma(T) \leq \gamma(T') + 3$ . We now get

$$2\gamma'(T') \leq 2\gamma'(T) - 4 = \gamma(T) - 4 \leq \gamma(T') + 3 - 4 < \gamma(T').$$

By Theorem 1 this case is impossible.

**Case (iv):** The vertex  $w$  is a support vertex. Let  $y$  be the leaf adjacent to  $w$ . Let  $T' = T - T_u$ . Let  $D$  be a  $\gamma'(T')$ -set. To dominate the edges  $vt, ux$  and  $wy$ , the edges  $uv, e \in D$  where  $e$  is the edge incident with  $w$  other than  $wy$ . It is obvious that  $D \setminus \{uv\}$  is an EDS of tree  $T'$ . Thus  $\gamma'(T') \leq \gamma'(T) - 1$ . Let  $S'$  be a  $\gamma(T')$ -set. The set  $S' \cup \{u, v\}$  is obviously a DS of tree  $T$ . This gives  $\gamma(T) \leq \gamma(T') + 2$ . We now get  $2\gamma'(T') \leq 2\gamma'(T) - 2 = \gamma(T) - 2 \leq \gamma(T')$ . This implies that  $2\gamma'(T') = \gamma(T')$ . The tree  $T' \in \mathcal{A}$  by the inductive hypothesis. The tree  $T$  can be constructed from  $T'$  by operation  $\mathcal{O}_3$ . Thus  $T \in \mathcal{A}$ .

**Case (v):** Now assume  $d_T(w) = 2$ . By the choice of the diametrical path, the vertex  $d$  is adjacent to isomorphic copy of  $T_w$  or path  $P_4$  or path  $P_3$  or path  $P_2$  or  $w$  is a support vertex or  $d_T(d) = 2$ .

**Subcase (i):** The vertex  $d$  is adjacent to isomorphic copy of  $T_w$ . Let  $D$  be a  $\gamma'(T)$ -set. To dominate the edges  $vt, uv, ux$  and  $uw$  the edge  $uv \in D$ . To dominate the edges in the isomorphic copy, the edges  $u'v' \in D$ . To dominate the edges incident with  $d$ , the edge  $de \in D$ . Let  $S$  be the set of vertices incident with edges in  $D$ . Clearly  $|S| \leq 2|D|$ . The set  $S \setminus \{d\}$  is a DS of  $T$ . We have  $\gamma(T) \leq 2|D| - 1 = 2\gamma'(T) - 1 < 2\gamma'(T)$ .

**Subcase (ii):** The vertex  $d$  is adjacent to 4-path  $a'b'c'd'$  with  $a'$  adjacent to  $d$ . Let  $D$  be a  $\gamma'(T)$ -set. As in subcase (i), the edge  $uv \in D$ . To dominate the edge  $da'$  and the edges in path  $P_4 : a'b'c'd'$ , the edges  $de, b'c' \in D$ . Let  $S$  be the set of vertices incident with edges in  $D$ . Clearly  $|S| \leq 2|D|$ . The set  $S \setminus \{b'\}$  is a DS of  $T$ . We have  $\gamma(T) \leq 2|D| - 1 = 2\gamma'(T) - 1 < 2\gamma'(T)$ .

**Subcase (iii):** The vertex  $d$  is adjacent to 3-path  $a'b'c'$  with  $a'$  adjacent to  $d$ . Let  $D$  be a  $\gamma'(T)$ -set. As in subcase (i), the edge  $uv \in D$ . To dominate the edge  $b'c'$ , the edge  $a'b' \in D$ . Let  $S$  be the set of vertices incident with edges in  $D$ . Clearly  $|S| \leq 2|D|$ . The set  $S \setminus \{a'\}$  is a DS of  $T$ . We have  $\gamma(T) \leq 2|D| - 1 = 2\gamma'(T) - 1 < 2\gamma'(T)$ .

**Subcase (iv):** The vertex  $d$  is adjacent to a 2-path  $a'b'$  with  $a'$  adjacent to  $d$ . Let  $T' = T - T_w$ . Let  $D$  be a  $\gamma'(T)$ -set. As in subcase (i), the edge  $uv \in D$ . To dominate the edges  $dw$  and  $a'b'$ , the edge  $da' \in D$ . It is easy to observe that  $D \setminus \{uv\}$  is an EDS of  $T'$ . Thus  $\gamma'(T') \leq \gamma'(T) - 1$ . Let  $S'$  be a  $\gamma(T')$ -set. The set  $S' \cup \{u, v\}$  is easily seen to be a DS of the tree  $T$ . Thus  $\gamma(T) \leq \gamma(T') + 2$ . We now obtain  $2\gamma'(T') \leq 2\gamma'(T) - 2 = \gamma(T) - 2 \leq \gamma(T')$ . This gives that  $2\gamma'(T') = \gamma(T')$ . The tree  $T' \in \mathcal{A}$  by the inductive hypothesis. The tree  $T$  can be constructed from  $T'$  by operation  $\mathcal{O}_4$ . Thus  $T \in \mathcal{A}$ .

**Subcase (v):** The vertex  $d$  is a support vertex. Let  $y$  be the leaf adjacent to  $d$ . Let  $T' = T - T_w$ . Arguing as in the previous subcase, we get  $\gamma(T') = 2\gamma'(T')$ . The tree  $T' \in \mathcal{A}$  by the inductive hypothesis. The tree  $T$  can be constructed from  $T'$  by operation  $\mathcal{O}_5$ . Thus  $T \in \mathcal{A}$ .

**Subcase (vi):** Now assume the degree of the vertex  $d$  is two. Let  $D$  be a  $\gamma'(T)$ -set. To dominate the edges in  $T_w$ , the edge  $uv \in D$ . To dominate the edge  $dw$ , the edge  $de \in D$ . Let  $S$



be the set of vertices incident with edges of  $D$ . Clearly  $|S| \leq 2|D|$ . The set  $S \setminus \{d\}$  is a DS of the tree  $T$ . Thus  $\gamma(T) \leq 2|D| - 1 = 2\gamma'(T) - 1 < 2\gamma'(T)$ .

Now assume  $d_T(u) = 2$ . Let  $T' = T - T_u$ . Let  $D$  be a  $\gamma'(T)$ -set. To dominate the edge  $vt$ , the edge  $uv \in D$ . The set  $D \setminus \{uv\}$  is verified to be an EDS of tree  $T'$ . Thus  $\gamma'(T') \leq \gamma'(T) - 1$ . Let  $S'$  be a  $\gamma(T')$ -set. The set  $S' \cup \{v\}$  is obviously a DS of tree  $T$ . Thus  $\gamma(T) \leq \gamma(T') + 1$ . We now obtain  $2\gamma'(T') \leq 2\gamma'(T) - 2 = \gamma(T) - 2 \leq \gamma(T') + 1 - 2 < \gamma(T')$ . By Theorem 1 this case is impossible.  $\square$

Characterization of trees with equal domination and twice the edge domination number is an immediate consequence of Lemma 1 and 2 and is stated as a theorem below.

**Theorem 2.** *Let  $T$  be a tree. Then  $2\gamma'(T) = \gamma(T)$  if and only if  $T \in \mathcal{A}$ .*

### 3. Concluding remarks

In this paper we characterize trees with domination number equal to twice edge domination number and present some problems for further research, among them we note the following:

1. Characterize graphs with equal domination number and twice edge domination number.
2. Characterize trees with equal domination number and edge domination number.
3. Characterize graphs with equal domination number and edge domination number.

### Acknowledgements

The authors thank the anonymous referees for their helpful and constructive comments leading to improvements in the presentation of the paper.

### REFERENCES

1. Arumugam S., Velammal S. Edge domination in graphs. *Taiwanese J. Math.*, 1998. Vol. 2, No. 2. P. 173–179. URL: <https://www.jstor.org/stable/43834391>
2. Haynes T. W., Hedetniemi S. T., Slater P. J. *Fundamentals of Domination in Graphs*. New York: Marcel Dekker, 1998. 455 p.
3. Haynes T. W., Hedetniemi S. T., Slater P. J. *Domination in Graphs: Advanced Topics*. New York: Marcel Dekker, 1998. 497 p.
4. Krishnakumari B., Venkatakrishnan Y.B., Krzywkowski M. On trees with total domination number equal to edge-vertex domination number plus one. *Proc. Math. Sci.*, 2016. Vol. 126. P. 153–157. DOI: [10.1007/s12044-016-0267-6](https://doi.org/10.1007/s12044-016-0267-6)
5. Liu C.L. *Introduction to Combinatorial Mathematics*. New York: McGraw Hill, 1968. 393 p.
6. Dorfling M., Goddard W., Henning M.A., Mynhardt C.M. Construction of trees and graphs with equal dominating parameters. *Discrete Math.*, 2006. Vol. 306, No. 21. P. 2647–2654. DOI: [10.1016/j.disc.2006.04.031](https://doi.org/10.1016/j.disc.2006.04.031)
7. Meddah N., Chellali M. Edges contained in all or in no minimum edge dominating set of a tree. *Discrete Math. Algorithms Appl.*, 2019. Vol. 11, No. 4. Art. no. 1950040. DOI: [10.1142/S179383091950040X](https://doi.org/10.1142/S179383091950040X)
8. Venkatakrishnan Y. B., Krishnakumari B. An improved upper bound of edge-vertex domination number of a tree. *Inform. Process. Lett.*, 2018. Vol. 134. P. 14–17. DOI: [10.1016/j.ipl.2018.01.012](https://doi.org/10.1016/j.ipl.2018.01.012)

# NONLOCAL PROBLEM FOR A MIXED TYPE FOURTH-ORDER DIFFERENTIAL EQUATION WITH HILFER FRACTIONAL OPERATOR

**Tursun K. Yuldashev**

National University of Uzbekistan named after Mirzo Ulugbek,  
700174 Tashkent, Uzbekistan  
[tursun.k.yuldashev@gmail.com](mailto:tursun.k.yuldashev@gmail.com)

**Bakhtiyor J. Kadirkulov**

Tashkent State Institute of Oriental Studies,  
25 Shaxrisabz, 100047 Tashkent, Uzbekistan  
[kadirkulovbj@gmail.com](mailto:kadirkulovbj@gmail.com)

**Abstract:** In this paper, we consider a non-self-adjoint boundary value problem for a fourth-order differential equation of mixed type with Hilfer operator of fractional integro-differentiation in a positive rectangular domain and with spectral parameter in a negative rectangular domain. The mixed type differential equation under consideration is a fourth order differential equation with respect to the second variable. Regarding the first variable, this equation is a fractional differential equation in the positive part of the segment, and is a second-order differential equation with spectral parameter in the negative part of this segment. A rational method of solving a nonlocal problem with respect to the Hilfer operator is proposed. Using the spectral method of separation of variables, the solution of the problem is constructed in the form of Fourier series. Theorems on the existence and uniqueness of the problem are proved for regular values of the spectral parameter. For sufficiently large positive integers in unique determination of the integration constants in solving countable systems of differential equations, the problem of small denominators arises. Therefore, to justify the unique solvability of this problem, it is necessary to show the existence of values of the spectral parameter such that the quantity we need is separated from zero for sufficiently large  $n$ . For irregular values of the spectral parameter, an infinite number of solutions in the form of Fourier series are constructed. Illustrative examples are provided.

**Keywords:** Mixed type equation, Non-self-adjoint boundary value problem, Hilfer operator, Mittag-Leffler function, Spectral parameter, Solvability.

## 1. Problem statement

In a rectangular domain  $\Omega = \{(t, x) : -a < t < b, 0 < x < 1\}$ , we consider the partial differential equation of mixed type

$$0 = \begin{cases} \left(D^{\alpha, \gamma} + \frac{\partial^4}{\partial x^4}\right)U(t, x), & (t, x) \in \Omega_1, \\ \left(\frac{\partial^2}{\partial t^2} + \omega^2 \frac{\partial^4}{\partial x^4}\right)U(t, x), & (t, x) \in \Omega_2, \end{cases} \quad (1.1)$$

where  $\Omega_1 = \Omega \cap (t > 0)$ ,  $\Omega_2 = \Omega \cap (t < 0)$ ,  $\omega$  is positive spectral parameter,  $a$  and  $b$  are positive real numbers,

$$D^{\alpha, \gamma} = J_{0+}^{\gamma-\alpha} \frac{d}{dt} J_{0+}^{1-\gamma} \quad (0 < \alpha \leq \gamma \leq 1)$$

is the Hilfer operator, and

$$I_{0+}^{\nu} \varphi(t) = \frac{1}{\Gamma(\nu)} \int_0^t (t-\tau)^{\nu-1} \varphi(\tau) d\tau, \quad \nu > 0$$

is the Riemann–Liouville integral operator [2, pp. 112, 113].

*Nonlocal problem.* It is required to find a function  $U(t, x)$ , which belongs to the class

$$t^{1-\gamma} \frac{\partial^k U}{\partial x^k} \in C(\overline{\Omega}_1), \quad \frac{\partial^k U}{\partial x^k} \in C(\overline{\Omega}_2), \quad D^{\alpha, \gamma} U \in C(\Omega_1), \quad U_{tt} \in C(\Omega_2), \quad U_{xxxx} \in C(\Omega_1 \cup \Omega_2), \quad (1.2)$$

$k = \overline{0, 3}$  and satisfies the homogeneous equation (1.1) in the domain  $\Omega_1 \cup \Omega_2$ , the homogeneous boundary value conditions

$$U|_{x=0} = \frac{\partial^2 U}{\partial x^2}|_{x=1} = 0, \quad \frac{\partial^k U}{\partial x^k}|_{x=0} = \frac{\partial^k U}{\partial x^k}|_{x=1}, \quad k = 1, 3, \quad t \neq 0, \quad (1.3)$$

the nonlocal condition

$$U(-a, x) = U(b, x) + \varphi(x), \quad 0 \leq x \leq 1, \quad (1.4)$$

and the gluing conditions

$$\lim_{t \rightarrow +0} J_{0+}^{1-\gamma} U(t, x) = \lim_{t \rightarrow -0} U(t, x), \quad \lim_{t \rightarrow +0} J_{0+}^{1-\alpha} \frac{d}{dt} J_{0+}^{1-\gamma} U(t, x) = \lim_{t \rightarrow -0} U_t(t, x), \quad (1.5)$$

where  $\varphi(x)$  is a given sufficiently smooth function.

Let  $(t_0; b) \subset \mathbb{R}^+ \equiv [0; \infty)$  be a finite interval, and let  $\alpha > 0$ . The Riemann–Liouville  $\alpha$ -order fractional integral of a function  $f$  is defined as follows:

$$I_{t_0+}^{\alpha} f(t) = \frac{1}{\Gamma(\alpha)} \int_{t_0}^t (t-s)^{\alpha-1} f(s) ds, \quad t \in (t_0; b),$$

where  $\Gamma(\alpha)$  is the Gamma function [2, p. 112].

Let  $n-1 < \alpha \leq n$ ,  $n \in \mathbb{N}$ . The Riemann–Liouville  $\alpha$ -order fractional derivative of a function  $f$  is defined as follows [9, Vol. 1, p. 27]:

$$D_{t_0+}^{\alpha} f(t) = \frac{d^n}{dt^n} I_{t_0+}^{n-\alpha} f(t), \quad t \in (t_0; b).$$

The Caputo  $\alpha$ -order fractional derivative of a function  $f$  is defined [9, Vol. 1, p. 34] by

$${}^*D_{t_0+}^{\alpha} f(t) = I_{t_0+}^{n-\alpha} f^{(n)}(t) = \frac{1}{\Gamma(n-\alpha)} \int_{t_0}^t \frac{f^{(n)}(s) ds}{(t-s)^{\alpha-n+1}}.$$

Both the derivatives are reduced to the  $n$ th order derivatives for  $\alpha = n \in \mathbb{N}$  [9, Vol. 1, pp. 27, 34]:

$$D_{t_0+}^n f(t) = {}^*D_{t_0+}^n f(t) = \frac{d^n f}{dt^n}.$$

The so-called generalized Riemann–Liouville fractional derivative (referred to as the Hilfer fractional derivative) of order  $\alpha$ ,  $n-1 < \alpha \leq n$ ,  $n \in \mathbb{N}$ , and type  $\beta$ ,  $0 \leq \beta \leq 1$ , is defined by the following composition of three operators: [2, p. 113]:

$$D_{t_0+}^{\alpha, \beta} f(t) = I_{t_0+}^{\beta(n-\alpha)} \frac{d^n}{dt^n} I_{t_0+}^{(1-\beta)(n-\alpha)} f(t).$$

For  $\beta = 0$ , this operator is reduced to the Riemann–Liouville fractional derivative ( $D_{t_0+}^{\alpha,0} = D_{t_0+}^{\alpha}$ ) and the case  $\beta = 1$  corresponds to the Caputo fractional derivative:  $D_{t_0+}^{\alpha,1} = {}_*D_{t_0+}^{\alpha}$ .

Let  $t_0 = 0$  and  $\gamma = \alpha + \beta n - \alpha\beta$ . It is easy to see that  $\alpha \leq \gamma \leq n$ . Then it is convenient to use another notation for the operator  $D_{0+}^{\alpha,\beta} f(t)$ :

$$D^{\alpha,\gamma} f(t) = D_{0+}^{\alpha,\beta} f(t). \quad (1.6)$$

For the first time, the generalized Riemann–Liouville operator was introduced in [2] by R. Hilfer on the basis of fractional time evolutions that arise during the transition from the microscopic scale to the macroscopic time scale. Using the integral transforms, he investigated the Cauchy problem for the generalized diffusion equation, the solution of which is presented in the form of the Fox H-function. We also note [10, 11], where the generalized Riemann–Liouville operator was used in studying dielectric relaxation in glass-forming liquids with different chemical compositions.

In [23], boundary value problems for a fractional diffusion equation with the Hilfer fractional derivative in finite and infinite domains were studied. In the finite domain, the spectral method and the Laplace transform method were used for solving the problem. In the domain infinite with respect to the spatial variable, the Cauchy problem was solved by the Fourier–Laplace integral transform method.

In [12], the properties of the generalized Riemann–Liouville operator were investigated in a special functional space, and an operational method was developed for solving fractional differential equations with this operator. Based on the results of [12], the authors of [15] have developed an operational method for solving fractional differential equations containing a finite linear combination of the generalized Riemann–Liouville operators with various parameters. In [17], the problem of source identification was studied for the generalized diffusion equation with the operator  $D^{\alpha,\gamma}$ . We also note the work [4], in which inverse problems were investigated for a generalized fourth-order parabolic equation with the operator  $D^{\alpha,\gamma}$ .

The construction of various models of theoretical physics problems by the aid of fractional calculus is described in [9, Vols. 4, 5], [16, 26]. A specific physical interpretation of the Hilfer fractional derivative, describing the random motion of a particle moving on the real line at Poisson paced times with finite velocity is given in [25]. A detailed review of the application of fractional calculus in solving applied problems is given in [9, Vols. 6–8], [19]. More detailed information as well as a bibliography related to the theory of fractional integro-differentiation, including the Hilfer fractional derivative, can be found in the recently published monograph [24]. In [7], the boundary value problems for the generalized modified moisture transfer equation and difference methods for their numerical implementation were considered.

Nonlocal problems can arise in studying various problems of mathematical biology, predicting soil moisture, problems of plasma. Note that nonlocal conditions of the type (1.3) take place in modeling the problems of the flow around a profile by a subsonic velocity stream with a supersonic zone [20]. More detailed information on nonlocal problems can be found in the monograph [18]. We would like to note some works [14, 30–32], where nonlocal problems for partial differential and integro-differential equations with derivatives of integer or fractional orders were studied.

As for the equations of mixed type, we note the work [8], where I.M. Gel'fand considered an example of gas motion in a channel surrounded by a porous medium, and the gas motion in a channel was described by a wave equation, while the diffusion equation was posed outside the channel. Ya. S. Uflyand considered a problem on the propagation of electric oscillations in compound lines when the losses on a semi-infinite line were neglected and the rest of the line was treated as a cable with no leaks [28]. He reduced this problem to a mixed parabolic-hyperbolic type equation. In [27], a hyperbolic-parabolic system arising in pulse combustion was investigated.

Nonlocal problems for partial differential equations of mixed type were studied by many authors, in particular, in [13, 21, 22, 29, 33]. We would like to note also the results on nonlocal problems

for parabolic-hyperbolic type equations with fractional order derivatives [1, 3]. But these listed works relate mainly to nonlocal problems for fractional mixed type equations of second order. As for mixed fourth-order equations with derivatives of integer or fractional orders, nonlocal problems in such formulation have not been previously studied.

In this paper, we consider a non-self-adjoint boundary value problem for a mixed type fourth-order differential equation with Hilfer operator of fractional integro-differentiation. The spectral method of separation of variables is used taking into account the features of the fractional integro-differentiation operator. We study the solvability of the nonlocal problem (1.1)–(1.5) for various values of the spectral parameter. This work is a further development and generalization of the results of [5, 6, 20].

## 2. Ordinary differential equation with Hilfer operator

We consider the Cauchy problem for a differential equation of fractional order with the operator  $D^{\alpha, \gamma}$

$$\begin{cases} D^{\alpha, \gamma} u(t) = \lambda u(t) + f(t), & t \in (0, \ell), \\ \lim_{t \rightarrow +0} J_{0+}^{1-\gamma} u(t) = u_0, \end{cases} \quad (2.1)$$

where  $f(t)$  is a given continuous function and  $u_0 = \text{const}$ .

Note that the Laplace method was used for solving this problem in [4]. In [15], a solution was found by the operational calculus for a problem more general than (2.1) in a specially constructed functional space. In our work, in contrast to these studies, we use a more rational way to solve problem (2.1), which allows us to obtain an explicit solution.

We prove the following Lemma.

**Lemma 1.** *Assume that  $f(t) \in C(0; \ell] \cap L_1(0; \ell)$ . Then a solution of problem (2.1)  $u(t) \in C(0; \ell] \cap L_1(0; \ell)$  is representable as follows:*

$$u(t) = u_0 t^{\gamma-1} E_{\alpha, \gamma}(\lambda t^\alpha) + \int_0^t (t-\tau)^{\alpha-1} E_{\alpha, \alpha}(\lambda(t-\tau)^\alpha) f(\tau) d\tau, \quad (2.2)$$

where

$$E_{\alpha, \beta}(z) = \sum_{k=0}^{\infty} \frac{z^k}{\Gamma(\alpha k + \beta)}, \quad z, \alpha, \beta \in \mathbb{C}, \quad \text{Re}(\alpha) > 0$$

is the Mittag-Leffler function [9, Vol. 1, pp. 269–295].

**P r o o f.** By virtue of the formula (1.6), we rewrite the differential equation of problem (2.1) in the form

$$J_{0+}^{\gamma-\alpha} D_{0+}^{\gamma} u(t) = \lambda u(t) + f(t).$$

Further, applying the operator  $J_{0+}^{\alpha}$  to both sides of this equation and taking into account the linearity of this operator and the following formula [15]:

$$J_{0+}^{\beta} D_{0+}^{\beta} u(t) = u(t) - \frac{1}{\Gamma(\gamma)} J_{0+}^{1-\beta} u(t)|_{t=0} t^{\beta-1},$$

we obtain

$$u(t) = \frac{u_0}{\Gamma(\gamma)} t^{\gamma-1} + J_{0+}^{\alpha} f(t) + \lambda J_{0+}^{\alpha} u(t). \quad (2.3)$$

Using the lemma from [6, p. 123], we represent the solution of equation (2.3) as

$$u(t) = \frac{u_0}{\Gamma(\gamma)} t^{\gamma-1} + J_{0+}^\alpha f(t) + \lambda \int_0^t (t-\tau)^{\alpha-1} E_{\alpha,\alpha}(\lambda(t-\tau)^\alpha) \left[ \frac{u_0}{\Gamma(\gamma)} \tau^{\gamma-1} + J_{0+}^\alpha f(\tau) \right] d\tau. \tag{2.4}$$

We rewrite representation (2.4) as the sum of two expressions  $u(t) = I_1(t) + I_2(t)$ , where

$$I_1(t) = u_0 \left[ \frac{t^{\gamma-1}}{\Gamma(\gamma)} + \frac{\lambda}{\Gamma(\gamma)} \int_0^t (t-\tau)^{\alpha-1} E_{\alpha,\alpha}(\lambda(t-\tau)^\alpha) \tau^{\gamma-1} d\tau \right], \tag{2.5}$$

$$I_2(t) = J_{0+}^\alpha f(t) + \lambda \int_0^t (t-\tau)^{\alpha-1} E_{\alpha,\alpha}(\lambda(t-\tau)^\alpha) J_{0+}^\alpha f(\tau) d\tau. \tag{2.6}$$

We make the change of variables  $s = t - \tau$  in formula (2.5) and use the following formulas [9, Vol. 1, pp. 269–295]:

$$E_{\alpha,\mu}(z) = \frac{1}{\Gamma(\mu)} + z E_{\alpha,\mu+\alpha}(t), \quad \alpha > 0, \quad \mu > 0, \tag{2.7}$$

$$\frac{1}{\Gamma(\nu)} \int_0^z (z-t)^{\nu-1} E_{\alpha,\beta}(\lambda t^\alpha) t^{\beta-1} dt = z^{\beta+\nu-1} E_{\alpha,\beta+\nu}(\lambda z^\alpha), \quad \nu > 0, \quad \beta > 0. \tag{2.8}$$

Then we obtain the following representation for integral (2.5):

$$I_1(t) = u_0 t^{\gamma-1} E_{\alpha,\gamma}(\lambda t^\alpha). \tag{2.9}$$

The integral in the formula (2.6) is transformed as follows:

$$\begin{aligned} & \int_0^t (t-\tau)^{\alpha-1} E_{\alpha,\alpha}(\lambda(t-\tau)^\alpha) J_{0+}^\alpha f(\tau) d\tau = \\ &= \frac{1}{\Gamma(\alpha)} \int_0^t (t-\tau)^{\alpha-1} E_{\alpha,\alpha}(\lambda(t-\tau)^\alpha) d\tau \int_0^\tau (\tau-s)^{\alpha-1} f(s) ds = \\ &= \frac{1}{\Gamma(\alpha)} \int_0^t f(s) ds \int_s^t (t-\tau)^{\alpha-1} (\tau-s)^{\alpha-1} E_{\alpha,\alpha}(\lambda(t-\tau)^\alpha) d\tau. \end{aligned} \tag{2.10}$$

In view of (2.8), the second integral in the latter equality of formula (2.10) can be written as

$$\int_s^t (t-\tau)^{\alpha-1} (\tau-s)^{\alpha-1} E_{\alpha,\alpha}(\lambda(t-\tau)^\alpha) d\tau = \Gamma(\alpha) (t-\tau)^{2\alpha-1} E_{\alpha,2\alpha}(\lambda(t-\tau)^\alpha).$$

Then, taking into account (2.7), we represent formula (2.6) in the following form:

$$I_2(t) = \int_0^t (t-\tau)^{\alpha-1} E_{\alpha,\alpha}(\lambda(t-\tau)^\alpha) f(\tau) d\tau. \tag{2.11}$$

Substituting (2.9) and (2.11) into the sum  $u(t) = I_1(t) + I_2(t)$ , we obtain formula (2.2). The lemma is proved. □

### 3. Uniqueness of solution of the nonlocal problem

We study this problem by the spectral method of separating variables and seek particular solutions of the nonlocal problem in the form of a product of two functions  $U(t, x) = u(t) \cdot \vartheta(x)$ . From equation (1.1) and boundary value conditions (1.3), we arrive at the following spectral problem:

$$\vartheta^{IV}(x) - \lambda^4 \vartheta(x) = 0, \quad \vartheta(0) = \vartheta''(1) = 0, \quad \vartheta'(1) = \vartheta'(1), \quad \vartheta'''(1) = \vartheta'''(1),$$

where  $\lambda^4$  is the constant of separation,  $0 < \lambda = \text{const}$ .

As follows from the results of [5], this spectral problem is non-self-adjoint and has a complete system of eigenfunctions of the following form in the space  $L_2(0; 1)$ :

$$\begin{aligned} \vartheta_0(x) = 2x, \quad \vartheta_{n1}(x) = 2 \sin \lambda_n x, \quad \vartheta_{n2}(x) = \frac{e^{\lambda_n x} - e^{\lambda_n(1-x)}}{e^{\lambda_n} - 1} + \cos \lambda_n x, \\ \lambda_n = 2\pi n, \quad n \in \mathbb{N}. \end{aligned} \quad (3.1)$$

System (3.1) forms a Riesz basis in  $L_2(0; 1)$ . In [5], it was also proved that there exists a biorthogonal system of functions with (3.1):

$$\eta_0(x) = 1, \quad \eta_{n1}(x) = \frac{e^{\lambda_n x} + e^{\lambda_n(1-x)}}{e^{\lambda_n} - 1} + \sin 2\pi n x, \quad \eta_{n2}(x) = 2 \cos \lambda_n x. \quad (3.2)$$

System (3.2) also forms a Riesz basis in  $L_2(0; 1)$ .

Let  $U(t, x)$  be a solution of the nonlocal problem. We consider the functions

$$u_0^+(t) = \int_0^1 U(t, x) dx, \quad u_{ni}^+(t) = \int_0^1 U(t, x) \eta_{ni}(x) dx, \quad t > 0, \quad (3.3)$$

$$u_0^-(t) = \int_0^1 U(t, x) dx, \quad u_{ni}^-(t) = \int_0^1 U(t, x) \eta_{ni}(x) dx, \quad i = 1, 2, \quad t < 0, \quad (3.4)$$

where the functions  $\eta_0(x)$  and  $\eta_{ni}(x)$ ,  $i = 1, 2$ , are defined in (3.2).

Applying the operator  $D^{\alpha, \gamma}$  with respect to  $t$  to both sides of equality (3.3), differentiating (3.4) twice with respect to  $t$ , and taking into account equation (1.1), we obtain differential equations with respect to the functions  $u_0^\pm(t)$  and  $u_{ni}^\pm(t)$ ,  $i = 1, 2$ :

$$D^{\alpha, \gamma} u_0^+(t) = 0, \quad D^{\alpha, \gamma} u_{ni}^+(t) + \lambda_n^4 u_{ni}^+(t) = 0, \quad i = 1, 2, \quad t > 0, \quad (3.5)$$

$$\frac{d^2}{dt^2} u_0^-(t) = 0, \quad \frac{d^2}{dt^2} u_{ni}^-(t) + \lambda_n^4 \omega^2 u_{ni}^-(t) = 0, \quad i = 1, 2, \quad t < 0. \quad (3.6)$$

The general solutions of these differential equations (3.5) and (3.6) have the form

$$u_0^\pm(t) = \begin{cases} \frac{A_0}{\Gamma(\gamma)} t^{\gamma-1}, & t > 0, \\ B_0 t + C_0, & t < 0, \end{cases} \quad u_{ni}^\pm(t) = \begin{cases} A_{ni} t^{\gamma-1} E_{\alpha, \gamma}(-\lambda_n^4 t^\alpha), & t > 0, \\ B_{ni} \sin \lambda_n^2 \omega t + C_{ni} \cos \lambda_n^2 \omega t, & t < 0, \end{cases} \quad (3.7)$$

where  $A_0$ ,  $B_0$ ,  $C_0$ ,  $A_{ni}$ ,  $B_{ni}$ , and  $C_{ni}$  are arbitrary constants,  $i = 1, 2$ ,  $n = 1, 2, \dots$ .

Taking into account conditions (1.4) and (1.5), we conclude from (3.3) and (3.4) that the functions  $u_0^\pm(t)$  and  $u_{ni}^\pm(t)$ ,  $i = 1, 2$ , in (3.7) must satisfy the following conditions:

$$\lim_{t \rightarrow +0} J_{0+}^{1-\gamma} u_0^+(t) = \lim_{t \rightarrow -0} u_0^-(t), \quad \lim_{t \rightarrow +0} J_{0+}^{1-\alpha} \left( \frac{d}{dt} J_{0+}^{1-\gamma} u_0^+(t) \right) = \lim_{t \rightarrow -0} \frac{d u_0^-(t)}{dt}, \quad (3.8)$$

$$\lim_{t \rightarrow +0} J_{0+}^{1-\gamma} u_{ni}^+(t) = \lim_{t \rightarrow -0} u_{ni}^-(t), \quad \lim_{t \rightarrow +0} J_{0+}^{1-\alpha} \left( \frac{d}{dt} J_{0+}^{1-\gamma} u_{ni}^+(t) \right) = \lim_{t \rightarrow -0} \frac{d u_{ni}^-(t)}{dt}, \quad (3.9)$$

$$u_0^-(-a) = u_0^+(b) + \varphi_0, \quad u_{ni}^-(-a) = u_{ni}^+(b) + \varphi_{ni}, \quad i = 1, 2, \quad (3.10)$$

where

$$\varphi_0 = \int_0^1 \varphi(x) dx, \quad \varphi_{ni} = \int_0^1 \varphi(x) \eta_{ni}(x) dx, \quad i = 1, 2, \quad n = 1, 2, \dots$$

Therefore, we obtain the following systems of algebraic equations:

$$\begin{cases} A_0 = C_0, & B_0 = 0, \\ -B_0 a + C_0 = \frac{A_0}{\Gamma(\gamma)} b^{\gamma-1} + \varphi_0, \end{cases} \quad (3.11)$$

$$\begin{cases} A_{ni} = C_{ni}, & \omega B_{ni} = -\lambda_n^2 A_{ni}, \\ -B_{ni} \sin \lambda_n^2 \omega a + C_{ni} \cos \lambda_n^2 \omega a - A_{ni} b^{\gamma-1} E_{\alpha, \gamma}(-\lambda_n^4 b^\alpha) = \varphi_{ni}. \end{cases} \quad (3.12)$$

Each of systems (3.11) and (3.12) has a unique solution

$$C_0 = A_0, \quad B_0 = 0, \quad A_0 = \frac{\varphi_0}{\Delta_0}, \quad C_{ni} = A_{ni} = \frac{\varphi_{ni}}{\Delta_n(\omega)}, \quad B_{ni} = -\frac{\lambda_n^2}{\omega} \frac{\varphi_{ni}}{\Delta_n(\omega)}, \quad (3.13)$$

if the following condition holds for all  $n \in \mathbb{N}_0 = \mathbb{N} \cup \{0\}$ :

$$\Delta_n(\omega) = \lambda_n^2 \omega \sin \lambda_n^2 \omega a + \cos \lambda_n^2 \omega a - b^{\gamma-1} E_{\alpha, \gamma}(-\lambda_n^4 b^\alpha) \neq 0. \quad (3.14)$$

Substituting (3.13) into (3.7), we obtain the representation

$$u_0^\pm(t) = \begin{cases} \frac{\varphi_0}{\Gamma(\gamma) \Delta_0} t^{\gamma-1}, & t > 0, \\ \frac{\varphi_0}{\Delta_0}, & t \leq 0, \end{cases} \quad (3.15)$$

$$u_{ni}^\pm(t) = \begin{cases} \frac{\varphi_{ni}}{\Delta_n(\omega)} t^{\gamma-1} E_{\alpha, \gamma}(-\lambda_n^4 t^\alpha), & t > 0, \\ \frac{\varphi_{ni}}{\Delta_n(\omega)} \left( \cos \lambda_n^2 \omega t - \frac{\lambda_n^2}{\omega} \sin \lambda_n^2 \omega t \right), & t \leq 0. \end{cases} \quad (3.16)$$

We show the uniqueness of the solution of the nonlocal problem under condition (3.14). Suppose the opposite. Let the nonlocal problem have two different solutions  $U_1(t, x)$  and  $U_2(t, x)$ , and let  $U(t, x) = U_1(t, x) - U_2(t, x)$ . It is not difficult to see that  $U(t, x)$  is a solution of the homogeneous nonlocal problem ( $\varphi(x) = 0$ ). This is why one only needs to prove that the homogeneous problem has only the trivial solution.

Suppose that condition (3.14) holds and  $\varphi(x) \equiv 0$ . Then  $\varphi_0 = 0$ ,  $\varphi_{ni} = 0$ ,  $i = 1, 2$ , and the representations (3.3), (3.4) and (3.15), (3.16) yield

$$\int_0^1 t^{1-\gamma} U(t, x) dx = 0, \quad \int_0^1 t^{1-\gamma} U(t, x) \eta_{ni}(x) dx = 0, \quad t \in [0; b],$$

$$\int_0^1 U(t, x) dx = 0, \quad \int_0^1 U(t, x) \eta_{ni}(x) dx = 0, \quad t \in [-a; 0], \quad i = 1, 2.$$



Further, taking into account the completeness of system (3.2) in the space  $L_2(0; 1)$ , we conclude that  $U(t, x) = 0$  almost everywhere on  $[0; 1]$  for all  $t \in [-a; b]$ . Since  $t^{1-\gamma}U(t, x) \in C(\overline{\Omega}_1)$  and  $U(t, x) \in C(\overline{\Omega}_2)$ , we have  $t^{1-\gamma}U(t, x) \equiv 0$  in the domain  $\overline{\Omega}$ . Therefore, the solution of the nonlocal problem is unique in the domain  $\overline{\Omega}$ .

Thus, we have proved the following theorem.

**Theorem 1.** *Suppose that there exists a solution of the nonlocal problem. This solution is unique if condition (3.14) holds for all  $n \in \mathbb{N}_0$ .*

#### 4. Existence of a solution of the nonlocal problem

Now we consider the case when condition (3.14) is violated. Let  $\Delta_m(\omega) = 0$  for all  $\omega, \gamma \in (0; 1)$  and  $n = m$ . Then the homogeneous nonlocal problem ( $\varphi(x) \equiv 0$ ) has a nontrivial solution

$$V_{mi}^\pm(t, x) = v_m^\pm(t) \vartheta_{mi}(x), \quad i = 1, 2, \quad (4.1)$$

where

$$v_m^\pm(t) = \begin{cases} t^{\gamma-1} E_{\alpha, \gamma}(-\lambda_m^4 t^\alpha), & t > 0, \\ \cos \lambda_m^2 \omega t - \frac{\lambda_m^2}{\omega} \sin \lambda_m^2 \omega t, & t < 0. \end{cases}$$

It is easy to verify that, for  $\gamma = 1$ , the function  $V(t, x) = x$  is also a nontrivial solution of the homogeneous nonlocal problem.

From  $\Delta_n(\omega) = 0$ , we come to the trigonometric equation

$$\sqrt{1 + \omega^2 \lambda_n^4} \sin(\lambda_n^2 \omega a + \rho_n) - b^{\gamma-1} E_{\alpha, \gamma}(-\lambda_n^4 b^\alpha) = 0, \quad (4.2)$$

where  $\rho_n = \arcsin\left(1/\sqrt{1 + \omega^2 \lambda_n^4}\right)$  and  $\rho_n \rightarrow 0$  as  $n \rightarrow +\infty$ . Hence, we conclude that the expression  $\Delta_n(\omega)$  is zero only if

$$\omega = \frac{1}{\lambda_n^2 a} \left[ (-1)^k \arcsin \frac{b^{\gamma-1} E_{\alpha, \gamma}(-\lambda_n^4 b^\alpha)}{\sqrt{1 + \omega^2 \lambda_n^4}} + \pi k - \rho_n \right], \quad k = 1, 2, \dots$$

The set  $\mathfrak{S}$  of positive solutions of trigonometric equation (4.2) is called the set of irregular values of the spectral parameter  $\omega$ .

The set of remaining values of the spectral parameter  $\aleph = (0; \infty) \setminus \mathfrak{S}$  is called the set of regular values of the spectral parameter  $\omega$ .

Since  $\Delta_n(\omega)$  is the denominator of a fraction and its values can become quite small for sufficiently large  $n$ , the problem of “small denominators” arises. Therefore, in order to justify the unique solvability of the nonlocal problem for regular values of the spectral parameter  $\omega$ , it is necessary to show that the quantity  $\Delta_n(\omega)$  is separated from zero for sufficiently large  $n$ .

**Lemma 2.** *Suppose that  $\gamma \in (0; 1]$ ,  $a$  and  $b$  are arbitrary positive real numbers, and  $\omega$  is such that the product  $\pi \omega a$  is a rational number. Then, for large  $n$ , there exists a positive constant  $M_0$  such that the following estimate holds:*

$$|\Delta_n(\omega)| \geq M_0 > 0. \quad (4.3)$$

**P r o o f.** I. We set  $\omega = p/\pi a$ ,  $p \in \mathbb{N}$ . Then we derive from (4.2) that, for all  $n$  and  $a, b > 0$ ,

$$|\Delta_n(\omega)| \geq \left| \pm \sqrt{1 + 16n^4 \pi^2 \frac{p^2}{a^2}} - b^{\gamma-1} E_{\alpha, \gamma}(-16n^4 \pi^4 b^\alpha) \right| \geq$$

$$\geq |1 - b^{\gamma-1} E_{\alpha,\gamma}(-16 n^4 \pi^4 b^\alpha)| \geq 1 - b^{\gamma-1} E_{\alpha,\gamma}(-16 n^4 \pi^4 b^\alpha).$$

We use the following properties of the Mittag-Leffler function [9, Vol. 1, pp. 269–295].

(1) For all  $\lambda > 0$ ,  $\alpha, \gamma \in (0; 1]$ ,  $\alpha \leq \gamma$ , and  $t > 0$ , the function  $t^{\alpha-1} E_{\alpha,\gamma}(-\lambda t^\alpha)$  is completely monotone, i.e.,

$$(-1)^n [t^{\gamma-1} E_{\alpha,\gamma}(-\lambda t^\alpha)]^{(n)} \geq 0, \quad n = 0, 1, 2, \dots \tag{4.4}$$

(2) The following estimate is true for all  $\alpha \in (0; 2)$ ,  $\gamma \in \mathbb{R}$ , and  $\arg z = \pi$ :

$$|E_{\alpha,\gamma}(z)| \leq \frac{M}{1+|z|}, \tag{4.5}$$

where  $0 < M = \text{const}$  is independent of  $z$ .

Then, (4.4) implies that there exists a number  $n_0 \in \mathbb{N}$  such that for all  $n > n_0$  we have

$$1 - b^{\gamma-1} E_{\alpha,\gamma}(-16 n^4 \pi^4 b^\alpha) = M_1 > 0.$$

Consequently,  $\Delta_n(\omega) \geq M_1 > 0$ .

II. Now we set

$$\frac{p}{q} = 4\pi\omega a \in \mathbb{Q} \Leftrightarrow \omega = \frac{1}{4\pi a} \frac{p}{q},$$

where  $p, q \in \mathbb{N}$ ,  $(p, q) = 1$ . We divide  $n^2 p$  by  $q$  with a remainder:  $n^2 p = sq + r$ ,  $s \in \mathbb{N}$ ,  $0 \leq r < q$ . Then from (4.1), we obtain

$$|\Delta_n(\omega)| = \left| \sqrt{1 + \left[\frac{\pi}{a} \left(s + \frac{r}{q}\right)\right]^2} (-1)^s \sin\left(\frac{\pi r}{q} + \rho_n\right) - b^{\gamma-1} E_{\alpha,\gamma}(-16 n^4 \pi^4 b^\alpha) \right|.$$

If  $r = 0$ , then this case reduces to case I.

Suppose that  $r > 0$ . Since  $\rho_n \rightarrow 0$  as  $n \rightarrow +\infty$ , there exists a number  $n_1 > 0$  such that  $\rho_n < \pi/(2q)$  for all  $n > n_1$ . Thus, we obtain the lower estimate

$$\begin{aligned} |\Delta_n(\omega)| &\geq \left| \sqrt{1 + \left[\frac{\pi}{a} \left(s + \frac{r}{q}\right)\right]^2} \sin\left(\frac{\pi r}{q} + \rho_n\right) - b^{\gamma-1} E_{\alpha,\gamma}(-16 n^4 \pi^4 b^\alpha) \right| \geq \\ &\geq \sqrt{1 + \left[\frac{\pi}{a} \left(s + \frac{r}{q}\right)\right]^2} \left| \sin\left(\frac{\pi r}{q} + \rho_n\right) \right| - b^{\gamma-1} E_{\alpha,\gamma}(-16 n^4 \pi^4 b^\alpha) > \\ &> \frac{\pi}{a} \left(s + \frac{r}{q}\right) \left| \sin\left(\frac{\pi(q-1)}{q} + \frac{\pi}{2q}\right) \right| - 1 = \frac{\pi}{a} \left(s + \frac{r}{q}\right) \sin \frac{\pi}{2q} - 1 = M_2 > 0 \end{aligned}$$

for

$$n_2 \geq \left[ a q \left( \pi p \sin \frac{\pi}{2q} \right)^{-1} \right]^{1/2}.$$

Setting  $M_0 > \max\{M_1, M_2\}$  and  $n > \max\{n_0, n_1, n_2\}$ , we complete the proof of the lemma. Lemma 2 is proved.  $\square$

We call the solution of the nonlocal problem (1.1)–(1.5) for regular values of the spectral parameter  $\omega$  a regular solution of the nonlocal problem. Estimates (4.3) and (4.5) imply the following lemma.

**Lemma 3.** *The following estimates hold for regular values of the spectral parameter  $\omega$ :*

$$\begin{aligned} t^{1-\gamma} |u_0^+(t)| &\leq C_1 |\varphi_0|, & t^{1-\gamma} |u_{ni}^+(t)| &\leq C_2 |\varphi_{ni}|, \\ t^{1-\gamma} \left| D^{\alpha, \beta} u_{ni}^+(t) \right| &\leq C_3 n^4 |\varphi_{ni}|, & i = 1, 2, & t \in [0; b]; \\ |u_0^-(t)| &\leq C_4 |\varphi_0|, & |u_{ni}^-(t)| &\leq C_5 n^2 |\varphi_{ni}|, \\ \left| \frac{d u_{ni}^-(t)}{dt} \right| &\leq C_6 n^4 |\varphi_{ni}|, & \left| \frac{d^2 u_{ni}^-(t)}{dt^2} \right| &\leq C_7 n^6 |\varphi_{ni}|, & i = 1, 2, & t \in [-a; 0], \end{aligned}$$

where  $C_k$ ,  $k = \overline{1, 7}$ , are positive constants.

Since system (3.1) is complete and forms a Riesz basis in  $L_2(0; 1)$ , we write the solution of the nonlocal problem for regular values of the spectral parameter  $\omega$  as

$$U(t, x) = \begin{cases} u_0^+(t) \vartheta_0(x) + \sum_{n=1}^{\infty} \sum_{i=1}^2 u_{ni}^+(t) \vartheta_{ni}(x), & (t, x) \in \Omega_1, \\ u_0^-(t) \vartheta_0(x) + \sum_{n=1}^{\infty} \sum_{i=1}^2 u_{ni}^-(t) \vartheta_{ni}(x), & (t, x) \in \Omega_2, \end{cases} \quad (4.6)$$

where  $u_0^\pm(t)$ ,  $u_{n1}^\pm(t)$ , and  $u_{n2}^\pm(t)$  are defined in (3.15) and (3.16).

Indeed, substituting function (4.6) into the mixed equation (1.1) and satisfying conditions (1.3)–(1.5), we obtain problems (3.5), (3.6), (3.8)–(3.10) with respect to the desired functions. The solutions of these problems can be represented as functions (3.15) and (3.16).

Now formally differentiating term-by-term the series (4.6) the required number of times, we obtain the series

$$D^{\alpha, \gamma} U(t, x) = \sum_{n=1}^{\infty} \sum_{i=1}^2 D^{\alpha, \gamma} u_{ni}^+(t) \vartheta_{ni}(x), \quad t > 0, \quad (4.7)$$

$$\frac{\partial^k U(t, x)}{\partial x^k} = u_0^+(t) \frac{d^k \vartheta_0(x)}{dx^k} + \sum_{n=1}^{\infty} \sum_{i=1}^2 u_{ni}^+(t) \frac{d^k \vartheta_{ni}(x)}{dx^k}, \quad k = \overline{1, 4}, \quad t > 0, \quad (4.8)$$

$$\frac{\partial^2 U(t, x)}{\partial t^2} = \sum_{n=1}^{\infty} \sum_{i=0}^2 \frac{d^2 u_{ni}^-(t)}{dt^2} \vartheta_{ni}(x), \quad t < 0, \quad (4.9)$$

$$\frac{\partial^k U(t, x)}{\partial x^k} = u_0^-(t) \frac{d^k \vartheta_0(x)}{dx^k} + \sum_{n=1}^{\infty} \sum_{i=1}^2 u_{n2}^-(t) \frac{d^k \vartheta_{n2}(x)}{dx^k}, \quad k = \overline{0, 4}, \quad t < 0. \quad (4.10)$$

By virtue of Lemma 2 and Lemma 3, we conclude that series (4.9) and (4.10) are majorized by the following sum of series:

$$\sum_{n=1}^{\infty} n^6 |\varphi_{n1}| + \sum_{n=1}^{\infty} n^6 |\varphi_{n2}|. \quad (4.11)$$

Multiplying series (4.7) and (4.8) term-by-term by  $t^{1-\gamma}$ , we obtain the series

$$\sum_{n=1}^{\infty} \sum_{i=1}^2 t^{1-\gamma} D^{\alpha, \gamma} u_{ni}^+(t) \vartheta_{ni}(x), \quad \sum_{n=1}^{\infty} \sum_{i=1}^2 t^{1-\gamma} u_{ni}^+(t) \frac{d^k \vartheta_{ni}(x)}{dx^k}, \quad k = \overline{0, 4}, \quad t > 0. \quad (4.12)$$

The series in (4.12) are also majorized by the series (4.11). Taking into account the fact that the function  $\varphi(x)$  is sufficiently smooth and integrating by parts

$$\varphi_{ni} = \int_0^1 \varphi(x) \eta_{ni}(x) dx, \quad i = 1, 2,$$

we derive

$$\begin{aligned} \varphi_{n1} &= -\frac{1}{(2\pi n)^\gamma} \varphi_{n1}^{(\gamma)} = -\frac{1}{(2\pi n)^\gamma} \left( \varphi^{(\gamma)}(x), \vartheta_{n2}(x) \right), \\ \varphi_{n2} &= \frac{1}{(2\pi n)^\gamma} \varphi_{n2}^{(\gamma)} = \frac{1}{(2\pi n)^\gamma} \left( \varphi^{(\gamma)}(x), \vartheta_{n1}(x) \right). \end{aligned}$$

By virtue of these representations, we apply the Cauchy–Schwartz inequality and Bessel inequality to (4.11)

$$\sum_{n=1}^{\infty} n^6 |\varphi_{ni}| \leq \sum_{n=1}^{\infty} \frac{1}{n} |\varphi_{ni}^{(\gamma)}| \leq \left( \sum_{n=1}^{\infty} \frac{1}{n^2} \right)^{1/2} \left( \sum_{n=1}^{\infty} |\varphi_{ni}^{(\gamma)}|^2 \right)^{1/2} \leq C \|\varphi^{(\gamma)}(x)\|_{L_2(0,1)} < \infty, \quad i = 1, 2.$$

This estimate implies that series (4.9) and (4.10) converge absolutely and uniformly in the domains  $\overline{\Omega}_1$  and  $\overline{\Omega}_2$ , respectively. Therefore, the function  $U(t, x)$ , represented by series (4.6), possesses properties (1.2) and satisfies conditions (1.3)–(1.5).

We note that  $\Delta_n(\omega) = 0$  for irregular values of the spectral parameter  $\omega$  and  $n = k_1, \dots, k_s$ ,  $1 \leq k_1 < k_2 < \dots < k_s$ ,  $s \in \mathbb{N}$  ( $\gamma \neq 1$ ). Then, the following orthogonality conditions are necessary and sufficient for the solvability of systems (3.11) and (3.12):

$$\varphi_{ni} = \int_0^1 \varphi(x) \eta_{ni} dx = 0, \quad i = 1, 2, \quad n = k_1, \dots, k_s. \tag{4.13}$$

In this case, the solutions of the nonlocal problem are representable as a sum of series

$$\begin{aligned} U(t, x) &= u_0^\pm(t) \vartheta_0(x) + \\ &+ \left[ \sum_{n=1}^{k_1-1} + \sum_{n=k_1+1}^{k_2-1} + \dots + \sum_{n=k_s+1}^{\infty} \right] \sum_{i=1}^2 u_{ni}^\pm(t) \vartheta_{ni}(x) + \sum_m \sum_{i=1}^2 C_{mi} V_{mi}^\pm(t), \end{aligned} \tag{4.14}$$

where  $m = k_1, \dots, k_s$ ,  $C_{mi}$  are arbitrary constants, and the functions  $V_{mi}^\pm(t)$ ,  $i = 1, 2$ , are defined in (4.1). Note that, in the case  $\gamma = 1$ , we replace the function  $u_0^\pm(t)$  in (4.14) with a constant  $C_0$ ; moreover, the orthogonality condition

$$\varphi_0 = \int_0^1 \varphi(x) dx = 0 \tag{4.15}$$

is added to formula (4.13).

Thus, the following theorem is proved.

**Theorem 2.** *Suppose that the following conditions are fulfilled:*

$$\begin{aligned} \varphi(x) &\in C^6[0; 1], \quad \varphi^{(\gamma)}(x) \in L_2(0; 1), \quad \varphi^{(2k)}(0) = 0, \\ \varphi^{(2(k+1))}(1) &= 0, \quad k = \overline{0, 2}, \quad \varphi^{(k)}(0) = \varphi^{(k)}(1), \quad k = 1, 3, 5. \end{aligned}$$

Then the nonlocal boundary value problem is uniquely solvable for regular values of the spectral parameter  $\omega$ , and this solution is represented in the form of the Fourier series (4.6) in the domain  $\Omega$ .

For irregular values of the spectral parameter  $\omega$  and some  $n = k_1, \dots, k_s$ , the nonlocal problem has an infinite number of solutions in the form of series (4.14).

For  $\gamma < 1$ , the solvability condition has the form (4.13). For  $\gamma = 1$  in (4.14), the function  $u_0^\pm(t)$  is replaced with a constant  $C_0$  and conditions (4.13), and (4.15) are the solvability conditions.

### 5. Stability of solution of the nonlocal problem

For regular values of the spectral parameter  $\omega$ , we consider the question of the stability of the solution of the nonlocal problem with respect to the function  $\varphi(x)$  from condition (1.4). To this end, we introduce the norm in the space of continuous functions as follows:

$$\begin{aligned} \|U(t, x)\|_{C(\bar{\Omega})} &= \|t^{1-\gamma}U(t, x)\|_{C(\bar{\Omega}_1)} + \|U(t, x)\|_{C(\bar{\Omega}_2)} = \\ &= \max_{(t, x) \in \bar{\Omega}_1} |t^{1-\gamma}U(t, x)| + \max_{(t, x) \in \bar{\Omega}_1} |U(t, x)|. \end{aligned}$$

**Theorem 3.** *Suppose that all the conditions of Theorem 2 are fulfilled. Then the following estimate holds for the solution of the nonlocal problem with regular values of the spectral parameter  $\omega$ :*

$$\|U(t, x)\|_{C(\bar{\Omega})} \leq C \|\varphi'''(x)\|_{C[0;1]}, \quad (5.1)$$

where  $0 < C = \text{const}$  is independent of  $\varphi(x)$  and  $\|f(x)\|_{C[0;1]} = \max_{[0;1]} |f(x)|$ .

*P r o o f.* Let  $(t, x)$  be an arbitrary point of the domain  $\bar{\Omega}_2$ . Then we have the representations

$$\begin{aligned} \varphi_{n1} &= -\frac{1}{\lambda_n^3} \varphi_{n1}^{(3)}, \quad \varphi_{n1}^{(3)} = \int_0^1 \varphi'''(x) \vartheta_{n2}(x) dx, \\ \varphi_{n2} &= \frac{1}{\lambda_n^3} \varphi_{n2}^{(3)}, \quad \varphi_{n2}^{(3)} = \int_0^1 \varphi'''(x) \vartheta_{n1}(x) dx. \end{aligned}$$

Applying Lemma 3 and the Cauchy–Schwarz inequality to (4.6), we obtain

$$\begin{aligned} \|U(t, x)\|_{C(\bar{\Omega}_2)} &\leq 2C_4|\varphi_0| + C_5 \sum_{n=1}^{\infty} \frac{1}{n} (|\varphi_{n1}^{(3)}| + |\varphi_{n2}^{(3)}|) \leq \\ &\leq 2C_4|\varphi_0| + C_5 \left( \sum_{n=1}^{\infty} \frac{1}{n^2} \right)^{1/2} \left( \sum_{n=1}^{\infty} (|\varphi_{n1}^{(3)}| + |\varphi_{n2}^{(3)}|)^2 \right)^{1/2}. \end{aligned}$$

It is well known that the former series converges. Applying the inequality  $(|a|+|b|)^2 \leq 2(|a|^2 + |b|^2)$  and the Bessel inequality to the latter series, we obtain

$$\sum_{n=1}^{\infty} (|\varphi_{n1}^{(3)}| + |\varphi_{n2}^{(3)}|)^2 \leq 2 \sum_{n=1}^{\infty} (|\varphi_{n1}^{(3)}|^2 + |\varphi_{n2}^{(3)}|^2) \leq C_{11} \|\varphi'''(x)\|_{L_2(0;1)}^2, \quad 0 < C_{11} = \text{const}. \quad (5.2)$$

Similarly, we can find for all  $(t, x) \in \bar{\Omega}_1$  that

$$\|t^{1-\gamma}U(t, x)\|_{C(\bar{\Omega}_1)} \leq C_{12} \|\varphi'''(x)\|_{L_2(0;1)}^2, \quad 0 < C_{12} = \text{const}. \quad (5.3)$$

Estimates (6.1) and (6.2) imply estimate (5.1), where  $C = C_{11} + C_{12}$ . If we assume that  $\|\varphi'''(x)\|_{L_2(0;1)}^2 < \delta$ , then the estimate  $\|U(t, x)\|_{C(\bar{\Omega})} < \varepsilon$  is true for all  $\varepsilon = C \cdot \delta$ . The theorem is proved.  $\square$

### 6. Illustrative examples

*Example 1.* Consider the nonlocal problem for  $\gamma = 1$ . Then we have  $D^{\alpha,\gamma} = D^{\alpha,1} = {}_C D^\alpha$  and equation (1.1) takes the form

$$0 = \begin{cases} {}_C D^\alpha U(t, x) + \frac{\partial^4 U(t, x)}{\partial x^4}, & t > 0, \\ \frac{\partial^2 U(t, x)}{\partial t^2} + \omega^2 \frac{\partial^4 U(t, x)}{\partial x^4}, & t < 0. \end{cases} \tag{6.1}$$

Equations (6.1) is a mixed type differential equation with the Caputo operator in a positive rectangular domain. We consider it under conditions (1.3)–(1.5). From (3.14), we obtain  $A_0 = \varphi_0 = 0$ , i.e., we arrive at condition (4.15). The solution of this problem with regular values of the spectral parameter  $\omega$  can be represented as

$$U(t, x) = \begin{cases} \sum_{n=1}^{\infty} \sum_{i=1}^2 \frac{\varphi_{ni}}{\Delta_n(\omega)} E_{\alpha,1}(-\lambda_n^4 t^\alpha) \vartheta_{ni}(x) + C_{01} x, & (t, x) \in \Omega_1, \\ \sum_{n=1}^{\infty} \sum_{i=1}^2 \frac{\varphi_{ni}}{\Delta_n(\omega)} \left( \cos \lambda_n^2 \omega t - \frac{\lambda_n^2}{\omega} \sin \lambda_n^2 \omega t \right) \vartheta_{ni}(x) + C_{02} x, & (t, x) \in \Omega_2, \end{cases}$$

where  $C_{0i} = \text{const}$ ,  $i = 1, 2$ .

*Example 2.* Consider the nonlocal problem for  $\gamma = \alpha < 1$ . Then we have  $D^{\alpha,\gamma} = D^{\alpha,\alpha} = {}_{RL} D^\alpha$  and equation (1.1) takes the form

$$0 = \begin{cases} {}_{RL} D^\alpha U(t, x) + \frac{\partial^4 U(t, x)}{\partial x^4}, & t > 0, \\ \frac{\partial^2 U(t, x)}{\partial t^2} + \omega^2 \frac{\partial^4 U(t, x)}{\partial x^4}, & t < 0. \end{cases} \tag{6.2}$$

Equation (6.2) is a mixed type differential equation with the Riemann–Liouville operator in a positive rectangular domain. We consider it under conditions (1.3)–(1.5). A solution of this problem with regular values of the spectral parameter  $\omega$  exists and is unique. This solution has a representation coinciding with (4.6) for  $\gamma = \alpha < 1$ .

*Example 3.* Consider the case  $\gamma = \alpha = 1$ . Then we have  $D^{\alpha,\gamma} = D^{1,1} = d/dt$  and equation (1.1) takes the form

$$0 = \begin{cases} \frac{\partial U(t, x)}{\partial t} + \frac{\partial^4 U(t, x)}{\partial x^4}, & t > 0, \\ \frac{\partial^2 U(t, x)}{\partial t^2} + \omega^2 \frac{\partial^4 U(t, x)}{\partial x^4}, & t < 0. \end{cases}$$

We obtained a mixed type differential equation of integer order, which is a particular case of equation (6.1) and, therefore, the solvability condition for this problem coincides with condition (4.15), and the solution of the nonlocal problem is represented as

$$U(t, x) = \begin{cases} \sum_{n=1}^{\infty} \sum_{i=1}^2 \frac{\varphi_{ni}}{\Delta_n(\omega)} e^{-\lambda_n^4 t} \vartheta_{ni}(x) + Ax, & (t, x) \in \Omega_1, \\ \sum_{n=1}^{\infty} \sum_{i=1}^2 \frac{\varphi_{ni}}{\Delta_n(\omega)} \left( \cos \lambda_n^2 \omega t - \frac{\lambda_n^2}{\omega} \sin \lambda_n^2 \omega t \right) \vartheta_{ni}(x) + Ax, & (t, x) \in \Omega_2, \end{cases}$$

where  $A = \text{const}$ .

## 7. Conclusion

We established a criterion for the existence and uniqueness of the regular solution of the nonlocal problem for a fourth-order differential equation of mixed type with Hilfer operator in a positive rectangular domain and with spectral parameter in a negative rectangular domain. We use the spectral method of separation of variables, which helps us to construct the solution of the nonlocal problem (1.1)–(1.5) in the form of Fourier series. Theorems on the existence and uniqueness of the problem are proved for regular values of the spectral parameter  $\omega$ . We study also the case of irregular values of spectral parameter  $\omega$ . Our theorem proving methods are based on expanding the regular solution using a biorthogonal set of functions. The stability of the regular solution of the nonlocal problem with respect to the data is proved.

## REFERENCES

1. Abdullaev O. Kh., Sadarangani K. Non-local problems with integral gluing condition for loaded mixed type equations involving the Caputo fractional derivative. *Electron. J. Differential Equations*, 2016. Vol. 2016. No. 164. P. 1–10. URL: <https://ejde.math.txstate.edu>
2. *Application of Fractional Calculus in Physics*. Hilfer R. (ed.) Singapore: World Scientific Publishing Company, 2000. 472 p. DOI: [10.1142/3779](https://doi.org/10.1142/3779)
3. Agarwal P., Berdyshev A., Karimov E. Solvability of a non-local problem with integral transmitting condition for mixed type equation with Caputo fractional derivative. *Results Math.*, 2017. Vol. 71, P. 1235–1257. DOI: [10.1007/s00025-016-0620-1](https://doi.org/10.1007/s00025-016-0620-1)
4. Aziz S., Malik S.A. Identification of an unknown source term for a time fractional fourth-order parabolic equation. *Electron. J. Differential Equations*, 2016. Vol. 2016. No. 293. P. 1–20. URL: <https://ejde.math.txstate.edu>
5. Berdyshev A. S., Cabada A., Kadirkulov B. J. The Samarskii–Ionkin type problem for the fourth order parabolic equation with fractional differential operator. *Comput. Math. Appl.*, 2011. Vol. 62. P. 3884–3893. DOI: [10.1016/j.camwa.2011.09.038](https://doi.org/10.1016/j.camwa.2011.09.038)
6. Berdyshev A. S., Kadirkulov J. B. On a nonlocal problem for a fourth-order parabolic equation with the fractional Dzhrbashyan–Nersesyan operator. *Differ. Equ.*, 2016. Vol. 52. No. 1. P. 122–127. DOI: [10.1134/S0012266116010109](https://doi.org/10.1134/S0012266116010109)
7. Beshtokov M. Kh. Boundary value problems for the generalized modified moisture transfer equation and difference methods for their numerical implementation. *Appl. Math. Phys.*, 2020. Vol. 52. No. 2. P. 128–138. DOI: [10.18413/2687-0959-2020-52-2-128-138](https://doi.org/10.18413/2687-0959-2020-52-2-128-138) (in Russian)
8. Gel'fand I. M. Some questions of analysis and differential equations. *Uspekhi Matem. Nauk.*, 1959. Vol. 14. No. 3. P. 3–19 (in Russian).
9. *Handbook of Fractional Calculus with Applications*. Vols. 1–8. Tenreiro Machado J. A. (ed.). Berlin, Boston: Walter de Gruyter GmbH, 2019.
10. Hilfer R. Experimental evidence for fractional time evolution in glass forming materials. *Chem. Phys.*, 2002. Vol. 284, No. 1–2. P. 399–408. DOI: [10.1016/S0301-0104\(02\)00670-5](https://doi.org/10.1016/S0301-0104(02)00670-5)
11. Hilfer R. On fractional relaxation. *Fractals*, 2003. Vol. 11. No. Supp. 01. Part III: Scaling. P. 251–257. DOI: [10.1142/S0218348X03001914](https://doi.org/10.1142/S0218348X03001914)
12. Hilfer R., Luchko Y., Tomovski Ž. Operational method for the solution of fractional differential equations with generalized Riemann–Liouville fractional derivatives. *Fract. Calc. Appl. Anal.*, 2009. Vol. 12, No. 3. P. 299–318. URL: <http://www.math.bas.bg/fcaa/volume12/fcaa123>
13. Kal'menov T. S., Sadybekov M. A. On a Frankl-type problem for a mixed parabolic-hyperbolic equation. *Sib. Math. J.*, 2017. Vol. 58. No. 2. P. 227–231. DOI: [10.1134/S0037446617020057](https://doi.org/10.1134/S0037446617020057)
14. Kerbal S., Kadirkulov B. J., Kirane M. Direct and inverse problems for a Samarskii–Ionkin type problem for a two dimensional fractional parabolic equation. *Progr. Fract. Differ. Appl.*, 2018. Vol. 4. No. 3. P. 147–160. DOI: [10.18576/pfda/040301](https://doi.org/10.18576/pfda/040301)
15. Kim M.-Ha, Ri G.-Chol, O. H.-Chol. Operational method for solving multi-term fractional differential equations with the generalized fractional derivatives. *Fract. Calc. Appl. Anal.*, 2014. Vol. 17. No. 1. P. 79–95. DOI: [10.2478/s13540-014-0156-6](https://doi.org/10.2478/s13540-014-0156-6)

16. Kumar D., Baleanu D. Editorial: fractional calculus and its applications in physics. *Front. Phys.*, 2019. Vol. 7. No. 6. P. 1–2. DOI: [10.3389/fphy.2019.00081](https://doi.org/10.3389/fphy.2019.00081)
17. Malik S.A., Aziz S. An inverse source problem for a two parameter anomalous diffusion equation with nonlocal boundary conditions. *Comput. Math. Appl.*, 2017. Vol. 73. No. 12. P. 2548–2560. DOI: [10.1016/j.camwa.2017.03.019](https://doi.org/10.1016/j.camwa.2017.03.019)
18. Nakhushev A. M. *Zadachi so smeshcheniem dlya uravnenij v chastnyh proizvodnyh* [Problems with Displacement for Partial Differential Equations]. Moscow: Nauka, 2006. 287 p. (in Russian).
19. Patnaik S., Hollkamp J. P., Semperlotti F. Applications of variable-order fractional operators: a review. *Proc. A.*, 2020. Vol. 476, No. 2234. P. 1–32. DOI: [10.1098/rspa.2019.0498](https://doi.org/10.1098/rspa.2019.0498)
20. Sabitov K.B. Nonlocal problem for a parabolic-hyperbolic equation in a rectangular domain. *Math. Notes*, 2011. Vol. 89, No. 4. P. 562–567. DOI: [10.1134/S0001434611030278](https://doi.org/10.1134/S0001434611030278)
21. Sabitov K.B. *K teorii uravnenij smeshannogo tipa* [On the Theory of Mixed Type Equations]. Moscow: Fizmatlit, 2014. 304 p. (in Russian).
22. Sabitov K.B., Sidorov S.N. On a nonlocal problem for a degenerating parabolic-hyperbolic equation. *Differ. Equ.*, 2014. Vol. 50. No. 3. P. 352–361. DOI: [10.1134/S0012266114030094](https://doi.org/10.1134/S0012266114030094)
23. Sandev T., Metzler R., Tomovski Ž. Fractional diffusion equation with a generalized Riemann-Liouville time fractional derivative. *J. Phys. A. Math. Theor.*, 2011. Vol. 44, No. 25. Art. no. 255203.
24. Sandev T., Tomovski Ž. *Fractional Equations and Models: Theory and Applications*. Dev. Math., vol. 61. Cham, Switzerland: Springer Nature Switzerland AG, 2019. 345 p. DOI: [10.1007/978-3-030-29614-8](https://doi.org/10.1007/978-3-030-29614-8)
25. Saxena R. K., Garra R., Orsingher E. Analytical solution of space-time fractional telegraph-type equations involving Hilfer and Hadamard derivatives. *Integral Transforms Spec. Funct.*, 2015. Vol. 27, No. 1. P. 30–42. DOI: [10.1080/10652469.2015.1092142](https://doi.org/10.1080/10652469.2015.1092142)
26. Sun H., Chang A., Zhang Y., Chen W. A review on variable-order fractional differential equations: mathematical foundations, physical models, numerical methods and applications. *Fract. Calc. Appl. Anal.*, 2019. Vol. 22, No. 1 P. 27–59. DOI: [10.1515/fca-2019-0003](https://doi.org/10.1515/fca-2019-0003)
27. Terlyga O., Bellout H., Bloom F. A hyperbolic-parabolic system arising in pulse combustion: existence of solutions for the linearized problem. *Electron. J. Differential Equations*, 2013. Vol. 2013. No. 46. P. 1–42. URL: <https://ejde.math.txstate.edu>
28. Uflyand Ya. S. K voprosu o rasprostranении kolebaniy v sostavnyh elektricheskikh liniyah [On oscillation propagation in compound electric lines]. *Inzhener.-Fiz. Zhurn. [J. of Engineering Physics and Thermophysics]*, 1964. Vol. 7. No. 1. P. 89–92 (in Russian).
29. Yuldashev T.K. Nonlocal problem for a mixed type differential equation in rectangular domain. *Proc. Yerevan State Univ. Phys. Math. Sci.*, 2016. No. 3. P. 70–78. URL: <http://mi.mathnet.ru/uzeru278>
30. Yuldashev T.K. Solvability of a boundary value problem for a differential equation of the Boussinesq type. *Differ. equ.*, 2018. Vol. 54. No. 10. P. 1384–1393. DOI: [10.1134/S0012266118100099](https://doi.org/10.1134/S0012266118100099)
31. Yuldashev T.K. A coefficient determination in nonlocal problem for Boussinesq type integro-differential equation with degenerate kernel. *Vladikavkaz. Mat. Zh.*, 2019. Vol. 21. No. 2. P. 67–84 (in Russian). DOI: [10.23671/VNC.2019.2.32118](https://doi.org/10.23671/VNC.2019.2.32118)
32. Yuldashev T.K. On a boundary-value problem for Boussinesq type nonlinear integro-differential equation with reflecting argument. *Lobachevskii J. Math.*, 2020. Vol. 41. No. 1. P. 111–123. DOI: [10.1134/S1995080220010151](https://doi.org/10.1134/S1995080220010151)
33. Yuldashev T.K. Nonlocal inverse problem for a pseudohyperbolic-pseudoelliptic type integro-differential equations. *Axioms*, 2020. Vol. 9. No. 2. Art. no. 45. P. 1–21. DOI: [10.3390/axioms9020045](https://doi.org/10.3390/axioms9020045)



# MOMENT PROBLEMS IN WEIGHTED $L^2$ SPACES ON THE REAL LINE

Elias Zikkos

Khalifa University, PO. Box 127788 Abu Dhabi, United Arab Emirates

[elias.zikkos@ku.ac.ae](mailto:elias.zikkos@ku.ac.ae)

**Abstract:** For a class of sets with multiple terms

$$\{\lambda_n, \mu_n\}_{n=1}^\infty := \underbrace{\{\lambda_1, \lambda_1, \dots, \lambda_1\}}_{\mu_1\text{-times}}, \underbrace{\{\lambda_2, \lambda_2, \dots, \lambda_2\}}_{\mu_2\text{-times}}, \dots, \underbrace{\{\lambda_k, \lambda_k, \dots, \lambda_k\}}_{\mu_k\text{-times}}, \dots,$$

having density  $d$  counting multiplicities, and a doubly-indexed sequence of non-zero complex numbers  $\{d_{n,k} : n \in \mathbb{N}, k = 0, 1, \dots, \mu_n - 1\}$  satisfying certain growth conditions, we consider a moment problem of the form

$$\int_{-\infty}^\infty e^{-2w(t)} t^k e^{\lambda_n t} f(t) dt = d_{n,k}, \quad \forall n \in \mathbb{N} \quad \text{and} \quad k = 0, 1, 2, \dots, \mu_n - 1,$$

in weighted  $L^2(-\infty, \infty)$  spaces. We obtain a solution  $f$  which extends analytically as an entire function, admitting a Taylor-Dirichlet series representation

$$f(z) = \sum_{n=1}^\infty \left( \sum_{k=0}^{\mu_n-1} c_{n,k} z^k \right) e^{\lambda_n z}, \quad c_{n,k} \in \mathbb{C}, \quad \forall z \in \mathbb{C}.$$

The proof depends on our previous work where we characterized the closed span of the exponential system  $\{t^k e^{\lambda_n t} : n \in \mathbb{N}, k = 0, 1, 2, \dots, \mu_n - 1\}$  in weighted  $L^2(-\infty, \infty)$  spaces, and also derived a sharp upper bound for the norm of elements of a biorthogonal sequence to the exponential system. The proof also utilizes notions from Non-Harmonic Fourier series such as Bessel and Riesz–Fischer sequences.

**Keywords:** Moment problems, Exponential systems, Biorthogonal families, Weighted Banach spaces, Bessel and Riesz–Fischer sequences.

## 1. Introduction

P. Malliavin [5] considered the following in the sense of the classical Bernstein weighted polynomial approximation problem on the real line. Let  $W(t)$  be a real-valued continuous function defined on the half-line  $[0, +\infty)$  such that it is log-convex, that is  $\log |W(e^s)|$  is a convex function on the real line. Let  $C_W$  be the weighted Banach space whose elements are the complex-valued continuous functions  $f$  defined on  $[0, \infty)$ , such that

$$\lim_{t \rightarrow \infty} \frac{f(t)}{W(t)} = 0,$$

equipped with the norm

$$\|f\|_W = \sup \left\{ \frac{|f(t)|}{W(t)} : t \in [0, \infty) \right\}.$$

Suppose also that  $\{\lambda_n\}_{n=1}^\infty$  is a strictly increasing sequence of positive real numbers diverging to infinity so that  $\liminf_{n \rightarrow \infty} (\lambda_{n+1} - \lambda_n) > 0$ . Malliavin proved [5, Theorem 8.3] that the span of the

system  $\{t^{\lambda_n}\}_{n=1}^\infty$  is not dense in  $C_W$  if and only if there exists  $\eta \in \mathbb{R}$  such that

$$\int_1^{+\infty} \frac{\log |W(e^{\sigma_\Lambda(t)-\eta})|}{t^2} dt < \infty, \quad \text{where } \sigma_\Lambda(t) = \sum_{\lambda_n \leq t} \frac{2}{\lambda_n}.$$

The question of the closure of the non-dense span of the system  $\{t^{\lambda_n}\}_{n=1}^\infty$  was later on addressed by J. M. Anderson and K. G. Binmore [1, Theorem 3]. Provided that the  $\lambda_n$  are positive integers, they proved that any function in the closure extends analytically as an entire function with a gap power series expansion of the form  $f(z) = \sum_{n=1}^\infty a_n z^{\lambda_n}$ .

We note that A. Borichev [2] gave a complete characterization of the closure of polynomials in certain weighted Banach spaces on  $\mathbb{R}$ , when  $W$  is an even log-convex function.

Motivated by the above results, we explored in [7, 8] the properties of a class of exponential systems

$$E_\Lambda := \{t^k e^{\lambda_n t} : n \in \mathbb{N}, k = 0, 1, 2, \dots, \mu_n - 1\},$$

in certain weighted Banach spaces on the real line. We note that such a system is associated to a set  $\Lambda = \{\lambda_n, \mu_n\}_{n=1}^\infty$  with multiple terms

$$\{\lambda_n, \mu_n\}_{n=1}^\infty := \underbrace{\{\lambda_1, \lambda_1, \dots, \lambda_1\}}_{\mu_1\text{-times}}, \underbrace{\{\lambda_2, \lambda_2, \dots, \lambda_2\}}_{\mu_2\text{-times}}, \dots, \underbrace{\{\lambda_k, \lambda_k, \dots, \lambda_k\}}_{\mu_k\text{-times}}, \dots\},$$

where

- $\{\lambda_n\}_{n=1}^\infty$  is a strictly increasing sequence of positive real numbers diverging to infinity,
- $\{\mu_n\}_{n=1}^\infty$  is a sequence of positive integers, not necessarily bounded.

We say that the set  $\Lambda$  is a multiplicity sequence.

In [7, 8] we assumed that the multiplicity sequence  $\Lambda$  belongs to a certain class denoted by  $U(d, 0)$ . This class and the weighted Banach spaces involved will be recalled in Section 2, while the main results from [7, 8] will be restated in Section 3.

In this paper we continue our investigations by considering a moment problem in a weighted  $L^2$  space on the real line. Our result, Theorem 4, is proved in Section 5. Prior to that, we introduce in Section 4 some notions from Non-Harmonic Fourier Series such as Bessel and Riesz–Fischer sequences that will play a decisive role.

The following interesting result is a special case of Theorem 4.

**Theorem 1.** *Let*

$$w(t) = \begin{cases} t^{2m+2}, & t \geq 0, \\ 0, & t < 0, \end{cases} \quad \text{where } m \in \mathbb{N}.$$

*Let  $\{p_n\}_{n=1}^\infty$  be the increasing sequence of prime numbers and let  $\mu_n = p_{n+1} - p_n$  for each  $n \in \mathbb{N}$ , that is,  $\mu_n$  is the distance between consecutive primes. Then, for any real number  $\gamma < 2$ , there exists an entire function  $f$  admitting a Taylor-Dirichlet series representation*

$$f(z) = \sum_{n=1}^\infty \left( \sum_{k=0}^{\mu_n-1} c_{n,k} z^k \right) e^{p_n z}, \quad c_{n,k} \in \mathbb{C}, \quad \forall z \in \mathbb{C},$$

*with the series converging uniformly on compact subsets of  $\mathbb{C}$ , so that*

$$\int_{-\infty}^\infty e^{-2w(t)} t^k e^{p_n t} f(t) dt = p_n^\gamma, \quad \forall n \in \mathbb{N} \quad \text{and} \quad k = 0, 1, 2, \dots, \mu_n - 1.$$

## 2. Notations and definitions from [7, 8]

### 2.1. Weighted Banach spaces

**Definition 1.** We denote by  $A_{\rho,\tau}$  the class of all non-negative convex functions  $w(t)$  defined on the real line that satisfy the following properties:

- (i)  $w(0) = 0$  and  $w(t) \geq t^2$ ,  $\forall t \geq \tau \geq 0$ ,
- (ii) there is some  $\rho > 0$  so that  $w(t) \leq \rho|t|$   $\forall t < 0$ ,
- (iii) for all  $A > 0$  there is a positive number  $t(A)$  such that  $w(t + A) \geq w(t) + t$ ,  $\forall t \geq t(A)$ .

*Example 1.* Let

$$w(t) = \begin{cases} t^{2m+2}, & t \geq 0, \\ 0, & t < 0, \end{cases} \quad \text{where } m \in \mathbb{N},$$

then  $w \in A_{\rho,\tau}$ .

For  $p \geq 1$  we denote by  $L_w^p$  the weighted Banach space of complex-valued measurable functions  $f$  defined on  $\mathbb{R}$  such that

$$\int_{-\infty}^{\infty} |f(t)e^{-w(t)}|^p dt < \infty,$$

equipped with the norm

$$\|f\|_{L_w^p} := \left( \int_{-\infty}^{\infty} |f(t)e^{-w(t)}|^p dt \right)^{1/p}.$$

As usual,  $L_w^2$  is a Hilbert space when endowed with the inner product

$$\langle f, g \rangle := \int_{-\infty}^{\infty} f(t)\overline{g(t)}e^{-2w(t)} dt.$$

### 2.2. The class of multiplicity sequences $U(d, 0)$

We say that a multiplicity sequence  $\Lambda = \{\lambda_n, \mu_n\}_{n=1}^{\infty}$  has finite density  $d$  counting multiplicities, if

$$\lim_{n \rightarrow \infty} \frac{n_{\Lambda}(t)}{t} = d < \infty, \quad \text{where } n_{\Lambda}(t) := \sum_{\lambda_n \leq t} \mu_n. \quad (2.1)$$

If  $\mu_n = 1$  for all  $n \in \mathbb{N}$  the above is equivalent to

$$\frac{n}{\lambda_n} \rightarrow d \quad \text{as } n \rightarrow \infty.$$

**Definition 2.** We denote by  $L(c, d)$  the class of strictly increasing sequences  $A = \{a_n\}_{n=1}^{\infty}$  having positive real terms  $a_n$  such that  $A$  has a finite density  $d$  and uniformly separated terms for some  $c > 0$ , that is,

$$\frac{n}{a_n} \rightarrow d \quad \text{as } n \rightarrow \infty, \quad a_{n+1} - a_n > c \quad \forall n \in \mathbb{N}.$$

Suppose now that a sequence  $A = \{a_n\}_{n=1}^\infty$  belongs to the class  $L(c, d)$ . Then choose two positive numbers  $\alpha, \delta$  so that

$$\alpha < 1 \quad \text{and} \quad \delta \leq \min\{4, c\}.$$

For each  $n \in \mathbb{N}$  consider the closed segment  $T_n := \{x : |x - a_n| \leq a_n^\alpha\} \subset \mathbb{R}$ . Then, choose a point in  $T_n$  that we call  $b_n$ , in an almost arbitrary way, in the sense that

$$\text{for all } n \neq m \quad \text{either} \quad (I) \quad b_m = b_n \quad \text{or} \quad (II) \quad |b_m - b_n| \geq \delta.$$

Hence a new sequence  $B = \{b_n\}_{n=1}^\infty$  is constructed.

We remark that the condition (I) allows for the presence of multiple terms in  $B$ . We may now rewrite  $B = \{b_n\}_{n=1}^\infty$  in the form of a multiplicity sequence  $\Lambda = \{\lambda_n, \mu_n\}_{n=1}^\infty$ , by grouping together all those terms that have the same modulus.

**Definition 3.** Fix a nonnegative constant  $d$ . We denote by  $U(d, 0)$  the class of all the multiplicity sequences  $\Lambda = \{\lambda_n, \mu_n\}_{n=1}^\infty$  constructed in the way described above from sequences  $A = \{a_n\}_{n=1}^\infty$  which belong to the class  $L(c, d)$ , for any positive constants  $\alpha, \delta, c$ , with  $\alpha < 1$  and  $\delta \leq \min\{4, c\}$ .

*Remark 1.* Clearly  $L(c, d)$  is a subclass of  $U(d, 0)$ .

We now mention two important properties of a sequence  $\Lambda \in U(d, 0)$  [8, Section 2].

- (1)  $\Lambda$  has the *same density*  $d$  counting multiplicities as the original sequence  $A$  from which it was constructed, that is, (2.1) holds.
- (2) There exists some  $\chi > 0$  independent of  $n$ , so that

$$\mu_n \leq \chi \lambda_n^\alpha \quad \forall n \in \mathbb{N}. \quad (2.2)$$

We also note that since  $\alpha < 1$ , then  $\mu_n/\lambda_n \rightarrow 0$  as  $n \rightarrow \infty$ , hence for every  $\epsilon > 0$  there is  $n(\epsilon) \in \mathbb{N}$  so that

$$\mu_n \leq \epsilon \lambda_n \quad \forall n \geq n(\epsilon). \quad (2.3)$$

*Remark 2.* We use the notation  $U(d, 0)$  since  $\Lambda$  has density  $d$  and  $\mu_n/\lambda_n \rightarrow 0$  as  $n \rightarrow \infty$ . That is, the second parameter in our notation stands for the relation between the multiplicities  $\mu_n$  and their corresponding frequencies  $\lambda_n$ .

An interesting multiplicity sequence in the  $U(1, 0)$  class with unbounded multiplicities is the following.

*Example 2.* Let  $\{p_n\}_{n=1}^\infty$  be the increasing sequence of prime numbers, and let  $\mu_n = p_{n+1} - p_n$  for each  $n \in \mathbb{N}$ . Then  $\Lambda = \{p_n, \mu_n\}_{n=1}^\infty$  belongs to the class  $U(1, 0)$ . It can be constructed in the way described above from the set  $\mathbb{N}$  of natural numbers which has density 1 (see [7, Example 1.3] and [8, Example 2.1]).

### 3. Our previous main results and the new one

Assuming that a multiplicity sequence  $\Lambda = \{\lambda_n, \mu_n\}_{n=1}^\infty$  belongs to the class  $U(d, 0)$ , we obtained in [7] necessary and sufficient conditions in order for the span of  $E_\Lambda$  to be dense in  $L_w^p$ .

**Theorem 2** [7, Theorem 1.1]. *Let  $w(t)$  be a function which belongs to the class  $A_{\rho,\tau}$  and suppose that  $\Lambda \in U(d, 0)$  for some  $d > 0$ . Then the span of the system  $E_\Lambda$  is not dense in  $L_w^p$  for all  $p \in [1, \infty)$ , if and only if there exists  $\eta \in \mathbb{R}$  such that*

$$\int_1^{+\infty} \frac{w(\sigma_\Lambda(t) - \eta)}{1 + t^2} dt < \infty, \quad \sigma_\Lambda(t) := 2 \sum_{\lambda_n \leq t} \frac{\mu_n}{\lambda_n}. \tag{3.1}$$

We then characterized in [8] the closure of the non-dense span of  $E_\Lambda$ . Moreover, in [8] we also derived an upper bound for the norm of the elements of a biorthogonal sequence

$$r_\Lambda := \{r_{n,k} : n \in \mathbb{N}, k = 0, 1, \dots, \mu_n - 1\} \subset L_w^2$$

to the system  $E_\Lambda$  in  $L_w^2$ , where biorthogonality means

$$\int_{-\infty}^{\infty} r_{n,k}(t)t^l e^{\lambda_j t} e^{-2w(t)} dt = \begin{cases} 1, & j = n, \quad l = k, \\ 0, & j = n, \quad l \in \{0, 1, \dots, \mu_n - 1\} \setminus \{k\}, \\ 0, & j \neq n, \quad l \in \{0, 1, \dots, \mu_j - 1\}. \end{cases}$$

**Theorem 3** [8, Theorems 2.1 and 6.1]. *Suppose that  $\Lambda \in U(d, 0)$  for some  $d > 0$ ,  $w(t) \in A_{\rho,\tau}$  and (3.1) holds.*

Part I. *Let  $f$  be a function which belongs to the closed span of  $E_\Lambda$  in  $L_w^p$  for some  $p \geq 1$ . Then there is an entire function  $g(z)$  which admits a Taylor-Dirichlet series representation*

$$g(z) = \sum_{n=1}^{\infty} \left( \sum_{k=0}^{\mu_n-1} c_{n,k} z^k \right) e^{\lambda_n z}, \quad c_{n,k} \in \mathbb{C}, \quad \forall z \in \mathbb{C},$$

with the series converging uniformly on compact subsets of  $\mathbb{C}$ , so that  $f(x) = g(x)$  almost everywhere on the real line.

Part II. *There is a unique biorthogonal sequence  $r_\Lambda$  to the system  $E_\Lambda$  in  $L_w^2$  which belongs to its closed span, such that for every  $\epsilon > 0$  there is a constant  $m_\epsilon > 0$ , independent of  $n$  and  $k$ , so that*

$$\|r_{n,k}\|_{L_w^2} \leq m_\epsilon \exp \{(-2d + \epsilon)\lambda_n \log \lambda_n\}, \quad \forall n \in \mathbb{N}, \quad k = 0, 1, \dots, \mu_n - 1. \tag{3.2}$$

Our aim in this article is to prove the following moment problem result.

**Theorem 4.** *Suppose that  $\Lambda \in U(d, 0)$  for some  $d > 0$ ,  $w(t) \in A_{\rho,\tau}$  and (3.1) holds. Consider a doubly-indexed sequence of non-zero complex numbers*

$$\{d_{n,k} : n \in \mathbb{N}, k = 0, 1, \dots, \mu_n - 1\}$$

such that

$$\limsup_{n \rightarrow \infty} \frac{\log A_n}{\lambda_n \log \lambda_n} = \gamma < 2d, \quad A_n = \max\{|d_{n,k}| : k = 0, 1, \dots, \mu_n - 1\}. \tag{3.3}$$

Then there exists a function  $f \in \overline{\text{span}}(E_\Lambda)$  in  $L_w^2$  that extends analytically as an entire function, admitting a Taylor-Dirichlet series representation

$$f(z) = \sum_{n=1}^{\infty} \left( \sum_{k=0}^{\mu_n-1} c_{n,k} z^k \right) e^{\lambda_n z}, \quad c_{n,k} \in \mathbb{C}, \quad \forall z \in \mathbb{C},$$

with the series converging uniformly on compact subsets of  $\mathbb{C}$ , so that

$$\int_{-\infty}^{\infty} e^{-2w(t)} t^k e^{\lambda_n t} f(t) dt = d_{n,k}, \quad \forall n \in \mathbb{N} \quad \text{and} \quad k = 0, 1, 2, \dots, \mu_n - 1. \tag{3.4}$$

We point out that similar moment problems were considered in [8, Theorems 1.2 and 7.1] but the solution obtained is a continuous function on  $\mathbb{R}$  rather than an entire function.

We also note that Theorem 1 follows by combining Theorem 4 with Example 1, Example 2, and

*Remark 3.* Suppose that  $\Lambda$  has a positive density  $d$ . A sufficient condition for (3.1) to hold (see the proof of [8, Theorem 2.2]) is if  $w(t) \in A_{\rho,\tau}$  such that

$$t^2 \leq w(t) \leq e^{\xi t}, \quad \forall t \geq \tau \geq 0, \quad 0 < \xi < \frac{1}{2d}.$$

The following results are direct consequences of Theorem 4.

**Corollary 1.** *Let  $w(t)$  be as in Example 1.*

- (A) *Suppose that  $\{\lambda_n\}_{n=1}^\infty$  is a sequence in the  $L(c, d)$  class for some  $d > 0$  and consider a sequence of non-zero complex numbers  $\{d_n\}_{n=1}^\infty$  such that*

$$\limsup_{n \rightarrow \infty} \frac{\log |d_n|}{\lambda_n \log \lambda_n} < 2d.$$

*Then there exists an entire function  $f$  admitting a Dirichlet series representation*

$$f(z) = \sum_{n=1}^\infty c_n e^{\lambda_n z}, \quad c_n \in \mathbb{C}, \quad \forall z \in \mathbb{C},$$

*with the series converging uniformly on compact subsets of  $\mathbb{C}$ , so that*

$$\int_{-\infty}^\infty e^{-2w(t)} e^{\lambda_n t} f(t) dt = d_n, \quad \forall n \in \mathbb{N}.$$

- (B) *There exist entire functions  $f$  and  $g$  admitting a Dirichlet series representation*

$$f(z) = \sum_{n=1}^\infty c_n e^{nz}, \quad g(z) = \sum_{n=1}^\infty d_n e^{nz},$$

*so that for all  $n \in \mathbb{N}$  we have*

$$\int_{-\infty}^\infty e^{-2w(t)} e^{nt} f(t) dt = n^n, \quad \int_{-\infty}^\infty e^{-2w(t)} e^{nt} g(t) dt = n!.$$

#### 4. Bessel and Riesz–Fischer sequences

The proof of Theorem 4 depends on Theorem 3 and utilizes the following notions from Non-Harmonic Fourier Series.

Let  $H$  be a separable Hilbert space endowed with an inner product  $\langle \cdot, \cdot \rangle$ , and consider two sequences  $\{f_n\}_{n=1}^\infty$  and  $\{g_n\}_{n=1}^\infty$  in  $H$ . We say that [6, Chapter 4, Section 2]:

- (i)  $\{f_n\}_{n=1}^\infty$  is a Bessel sequence if there exists a constant  $B > 0$  such that

$$\sum_{n=1}^\infty |\langle f, f_n \rangle|^2 < B \|f\|^2 \quad \forall f \in H.$$

- (ii)  $\{g_n\}_{n=1}^\infty$  is a Riesz–Fischer sequence if the moment problem  $\langle f, g_n \rangle = c_n$  has at least one solution  $f \in H$  for every sequence  $\{c_n\}_{n=1}^\infty$  in the space  $l^2(\mathbb{N})$ .

*Remark 4.* It follows from [3, Proposition 2.3] that if two sequences  $\{f_n\}_{n=1}^\infty$  and  $\{g_n\}_{n=1}^\infty$  in  $H$  are biorthogonal, that is

$$\langle f_n, g_m \rangle = \begin{cases} 1, & m = n, \\ 0, & m \neq n, \end{cases}$$

and  $\{f_n\}_{n=1}^\infty$  is a Bessel sequence, then  $\{g_n\}_{n=1}^\infty$  is a Riesz–Fischer sequence.

We give now a sufficient condition in order for  $\{g_n\}_{n=1}^\infty$  to be a Riesz–Fischer sequence.

**Lemma 1.** *Let  $H$  be a separable Hilbert space and consider two biorthogonal sequences  $\{f_n\}_{n=1}^\infty$  and  $\{g_n\}_{n=1}^\infty$  in  $H$ . Let  $c_{n,m} = \langle f_n, f_m \rangle$  and let  $C = (c_{n,m})$  be the Hermitian Gram matrix associated with  $\{f_n\}_{n=1}^\infty$ . If there is some  $M > 0$  so that*

$$\sum_{n=1}^{\infty} |c_{n,m}| < M \quad \text{for all } m = 1, 2, 3, \dots, \quad (4.1)$$

then  $\{f_n\}_{n=1}^\infty$  and  $\{g_n\}_{n=1}^\infty$  are Bessel and Riesz–Fischer sequences respectively in  $H$ .

*P r o o f.* Relation (4.1) implies that the Gram matrix  $C$  defines a bounded linear operator on the space of sequences  $l^2(\mathbb{N})$  (see [4, Lemma 3.5.3] and [6, Sec. 4.2, Lemma 1]). It then follows by [4, Lemma 3.5.1] that  $\{f_n\}_{n=1}^\infty$  is a Bessel sequence in  $H$ . By Remark 4 we conclude that  $\{g_n\}_{n=1}^\infty$  is a Riesz–Fischer sequence in  $H$ .  $\square$

## 5. Proof of Theorem 4

Clearly  $\overline{\text{span}}(E_\Lambda)$  in  $L_w^2$  is a separable Hilbert space and let us denote this space by  $H_\Lambda$ . From Theorem 3 (Part II), let  $\{r_{n,k}\}$  be the biorthogonal sequence to  $E_\Lambda$  which belongs to its closed span.

Then, define for every  $n \in \mathbb{N}$  and  $k = 0, 1, \dots, \mu_n - 1$  the following:

$$U_{n,k}(t) := \lambda_n d_{n,k} r_{n,k}(t) \quad \text{and} \quad V_{n,k}(t) := \frac{t^k e^{\lambda_n t}}{\lambda_n d_{n,k}}.$$

It easily follows that  $\{U_{n,k}\}$  and  $\{V_{n,k}\}$  are biorthogonal sequences in  $H_\Lambda$ .

We now claim that  $\{U_{n,k}\}$  and  $\{V_{n,k}\}$  are Bessel and Riesz–Fischer sequences respectively in  $H_\Lambda$ . First, since (3.2) and (3.3) hold, if we let  $\epsilon = (2d - \gamma)/2$  we get

$$\|U_{n,k}\|_{L_w^2} \leq e^{-\epsilon \lambda_n}, \quad \forall n \in \mathbb{N} \quad \text{and} \quad k = 0, 1, 2, \dots, \mu_n - 1.$$

Then, by the Cauchy-Schwartz inequality we get

$$|\langle U_{n,k}, U_{m,j} \rangle| \leq e^{-\epsilon \lambda_n} \cdot e^{-\epsilon \lambda_m}, \quad \forall n, m \in \mathbb{N} \quad k = 0, 1, 2, \dots, \mu_n - 1 \quad j = 0, 1, 2, \dots, \mu_m - 1. \quad (5.1)$$

Next, let  $c_{n,k,m,j}$  be the value of  $\langle U_{n,k}, U_{m,j} \rangle$  and let  $C$  be the infinite dimensional hermitian matrix with entries the  $c_{n,k,m,j}$ 's, that is  $C$  is the Gram matrix associated with  $\{U_{n,k}\}$ . From (2.3) and (5.1) we get

$$\sum_{n=1}^{\infty} \sum_{k=0}^{\mu_n-1} \sum_{m=1}^{\infty} \sum_{j=0}^{\mu_m-1} |c_{n,k,m,j}| < \infty.$$

It then follows from Lemma 1 that our claim is valid.

Thus, the moment problem

$$\int_{-\infty}^{\infty} f(t) \overline{V_{n,k}(t)} e^{-2w(t)} dt = a_{n,k} \quad \forall n \in \mathbb{N} \quad \text{and} \quad k = 0, 1, 2, \dots, \mu_n - 1,$$

has a solution in  $H_\Lambda$  whenever  $\sum_{n=1}^{\infty} \sum_{k=0}^{\mu_n-1} |a_{n,k}|^2 < \infty$ . Now, if we let

$$a_{n,k} = \frac{1}{\lambda_n} \quad \forall n \in \mathbb{N} \quad \text{and} \quad k = 0, 1, \dots, \mu_n - 1,$$

then the density of  $\Lambda$  and relation (2.2) imply that

$$\sum_{n=1}^{\infty} \sum_{k=0}^{\mu_n-1} |a_{n,k}|^2 = \sum_{n=1}^{\infty} \frac{\mu_n}{\lambda_n^2} < \infty.$$

Thus,  $\{a_{n,k}\}$  belongs to the space  $l^2(\mathbb{N})$ . Hence, and recalling the definition of  $V_{n,k}$ , there is some function  $f \in H_\Lambda$  so that

$$\int_{-\infty}^{\infty} f(t) \left( \frac{t^k e^{\lambda_n t}}{d_{n,k} \lambda_n} \right) e^{-2w(t)} dt = \frac{1}{\lambda_n}, \quad \forall n \in \mathbb{N} \quad \text{and} \quad k = 0, 1, 2, \dots, \mu_n - 1.$$

Clearly now (3.4) holds.

Finally, since  $f \in H_\Lambda$  it follows from Theorem 3 (Part I) that  $f$  extends analytically as an entire function admitting a Taylor–Dirichlet series representation. Our proof is now complete.

## REFERENCES

1. Anderson J. M., Binmore K. G. Closure theorems with applications to entire functions with gaps. *Trans. Amer. Math. Soc.*, 1971. Vol. 161. P. 381–400. DOI: [10.2307/1995948](https://doi.org/10.2307/1995948)
2. Borichev A. On the closure of polynomials in weighted spaces of functions on the real line. *Indiana Univ. Math. J.*, 2001. Vol. 50. No. 2. P. 829–846. DOI: [10.1512/iumj.2001.50.2044](https://doi.org/10.1512/iumj.2001.50.2044)
3. Casazza P., Christensen O., Li S., Lindner A. Riesz–Fischer sequences and lower frame bounds. *Z. Anal. Anwend.*, 2002. Vol. 21. No. 2. P. 305–314. DOI: [10.4171/ZAA/1079](https://doi.org/10.4171/ZAA/1079)
4. Christensen O. *An Introduction to Frames and Riesz Bases*. Appl. Numer. Harmon. Anal. Basel: Birkhäuser, Springer, 2003. 440 p. DOI: [10.1007/978-0-8176-8224-8](https://doi.org/10.1007/978-0-8176-8224-8)
5. Malliavin P. Sur quelques procédés d’extrapolation. *Acta Math.*, 1955. Vol. 93. P. 179–255. DOI: [10.1007/BF02392523](https://doi.org/10.1007/BF02392523)
6. Young R. M. *An Introduction to Nonharmonic Fourier Series*. Revised first edition. San Diego, CA: Academic Press, Inc., 2001. 234 p.
7. Zikkos E. Completeness of an exponential system in weighted Banach spaces and closure of its linear span. *J. Approx. Theory*, 2007. Vol. 146. No. 1. P. 115–148. DOI: [10.1016/j.jat.2006.12.002](https://doi.org/10.1016/j.jat.2006.12.002)
8. Zikkos E. The closed span of some exponential system in weighted Banach spaces on the real line and a moment problem. *Analysis Math.*, 2018. Vol. 44. No. 4. P. 605–630. DOI: [10.1007/s10476-018-0311-0](https://doi.org/10.1007/s10476-018-0311-0)



---

Editor: Tatiana F. Filippova  
Managing Editor: Oxana G. Matviychuk  
Design: Alexander R. Matviychuk

---

Contact Information

16 S. Kovalevskaya str., Ekaterinburg, Russia, 620990

Phone: +7 (343) 375-34-73

Fax: +7 (343) 374-25-81

Email: [secretary@umjuran.ru](mailto:secretary@umjuran.ru)

Web-site: <https://umjuran.ru>

N.N. Krasovskii Institute of Mathematics and Mechanics  
of the Ural Branch of Russian Academy of Sciences

Ural Federal University named after the first President of Russia B.N. Yeltsin

Distributed for free